

TECHNICAL SPECIFICATIONS
JONSERED 1188S



BUILT TO PERFORM



JONSERED

JONSERED 1188S BASIC DATA

TECHNICAL DATA	J1188S 79	J1188S 83	J1188S 84	J1188S 88	J1188S 96	J1188S 101
Max. lifting capacity (ft-lbs)	380 580	377 300	370 730	367 450	354 330	341 210
Outreach, hydraulic extensions (ft)	25' 11"	27' 3"	27' 6"	28' 10"	31' 6"	33' 2"
Outreach / lifting capacity (ft-lbs)	9' 10" - 7 170 13' 1" - 6 170 16' 5" - 5 110 19' 8" - 4 320 23' 0" - 3 700 25' 11" - 3 220 -	9' 10" - 7 170 13' 1" - 6 060 16' 5" - 4 980 19' 8" - 4 320 23' 0" - 3 700 27' 3" - 3 000 -	9' 10" - 7 610 13' 1" - 6 060 16' 5" - 4 940 19' 8" - 4 190 23' 0" - 3 620 27' 6" - 2 950 -	9' 10" - 7 280 13' 1" - 5 950 16' 5" - 4 850 19' 8" - 4 140 23' 0" - 3 570 26' 3" - 3 130 28' 10" - 2 730 -	9' 10" - 7 390 13' 1" - 5 840 16' 5" - 4 720 19' 8" - 4 010 23' 0" - 3 440 26' 3" - 2 950 29' 6" - 2 600 31' 5" - 2 140	9' 10" - 7 500 13' 1" - 5 620 16' 5" - 4 590 19' 8" - 3 880 23' 0" - 3 310 26' 3" - 2 870 29' 6" - 2 510 33' 2" - 2 140
Slewing system	Double	Double	Double	Double	Double	Double
Slewing angle (°)	425	425	425	425	425	425
Slewing torque, gross (ft-lbs)	27 500	27 500	27 500	27 500	27 500	27 500
Max. working pressure (psi)	3 480	3 480	3 480	3 480	3 480	3 480
Min. oil flow - variable displacement pump (gal/min)	45	45	45	45	45	45
Weight, high seat crane (lbs)	4 500	4 520	4 540	4 590	4 890	4 960
Weight, HiVision crane (lbs)	4 780	4 810	4 830	4 870	5 180	5 250
Weight, cabin crane (lbs)	5 400	5 420	5 450	5 470	5 800	5 860

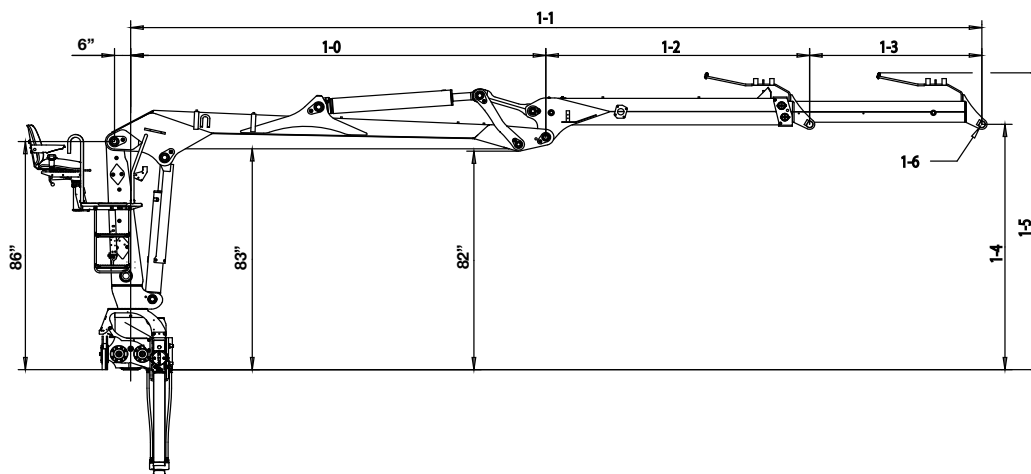

MODEL	1-0	1-1 MIN	1-1 MAX	1-2	1-3	1-4	1-5	1-6
79 (in)	120	251	313	99	62	92	106	Ø1.5, B=7
83 (in)	120	258	327	106	69	92	106	Ø1.5, B=7
84 (in)	171	270	333	99	62	93	106	Ø1.5, B=7
88 (in)	171	277	347	106	69	93	106	Ø1.5, B=7
96 (in)	120	254	377	102	124	94	108	Ø1.5, B=7
101 (in)	171	273	397	102	124	94	108	Ø1.5, B=7

Disclaimer. Hiab cranes have been built to meet the highest standards of safety and service life and have been thoroughly tested. Strength calculations for this model have been carried out in accordance with EN13001 in fatigue class S2. Cargotec's certified Quality Assurance System complies with ISO 9001. Some of the items in our literature may be extra equipment. Certain applications may require an official permit. We reserve the right to change technical specifications without prior notice. Hiab cranes produced for EU-countries are CE marked and comply with the European Standard EN12999.

Hiab is the world's leading provider of on-road load handling equipment. Customer satisfaction is the first priority for us. Hiab's product range includes HIAB loader cranes, JONSERED recycling and forestry cranes, LOGLIFT forestry cranes, MOFFETT truck mounted forklifts, and MULTILIFT demountables, as well as DEL, WALTCO, and ZEPRO tail lifts.

www.hiab.us.com
Hiab is part of Cargotec.
www.cargotec.com

Hiab USA Inc
12233 Williams Road
Perrysburg, OH 43551 USA
tel. 419 482 6000
fax. 419 482 6001

