

YIELD STRENGTH	CRANE MINIMUM SECTION MODULUS REQUIRED
120,000 P.S.I. YIELD	= 55.26 in. ³
CRANE MINIMUM RBM/RAIL = 6,630,905 IN-LBS	

CRANE MAY BE DERATED IN FRONT QUADRANTS AS MUCH AS 45%. ACTUAL DERATING SHALL BE BASED ON PHYSICAL TESTING.

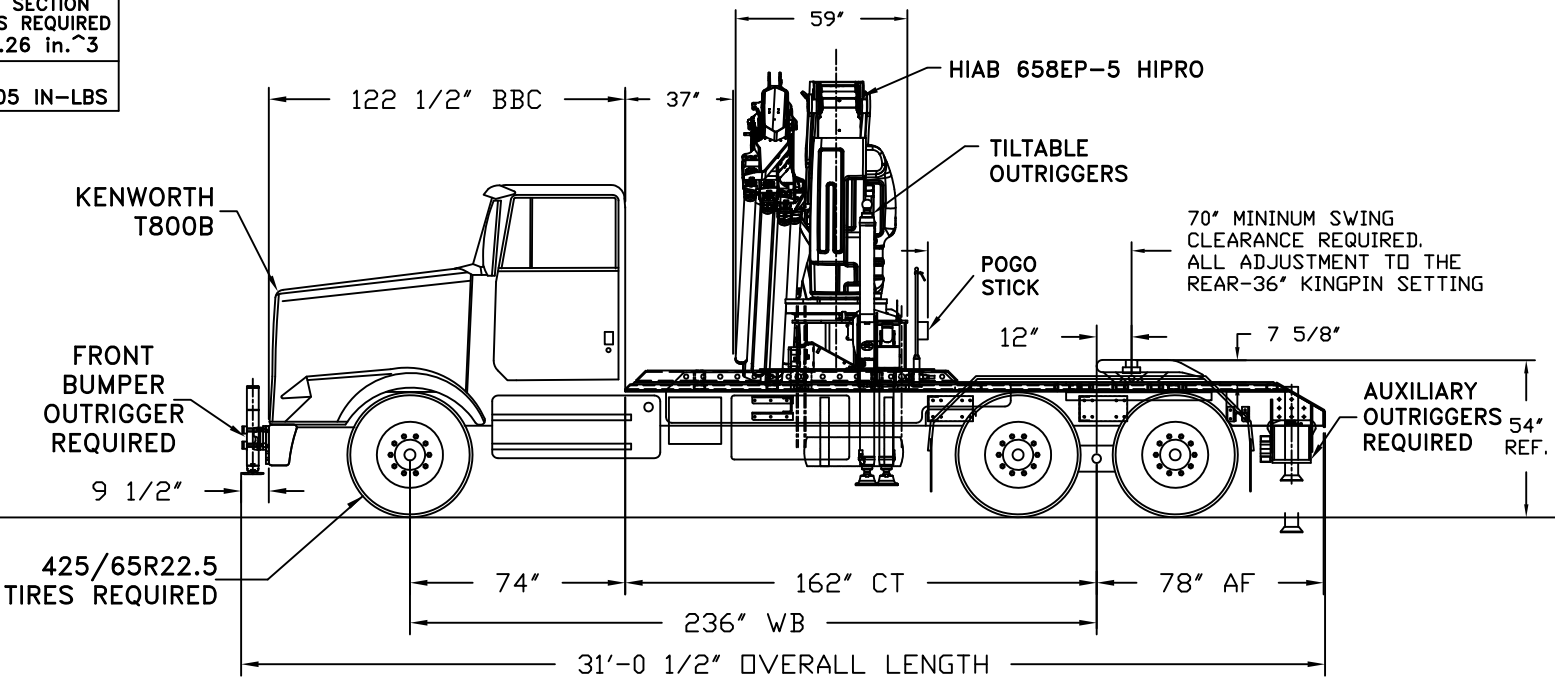

TRACTOR, HIAB CRANE AND ACCESSORIES WEIGHT DISTRIBUTION, NO LOAD AT FIFTH WHEEL.	
FRONT AXLE LOAD	= 18,960 LBS.
TANDEM AXLE LOAD	= 24,850 LBS.
FRONT AXLE PERCENTAGE	= 43 %
TANDEM AXLE PERCENTAGE	= 57 %
GROSS VEHICLE WEIGHT	= 43,810 LBS.

TRACTOR SPECIFICATIONS	
TRACTOR MODEL	= KENWORTH T800B
WHEELBASE	= 236"
CAB TO TANDEM	= 162"
AXLE-TO-FRAME	= 78"
FRONT AXLE TARE WEIGHT	= 11,022 LBS.
TANDEM AXLE TARE WEIGHT	= 9,100 LBS.
FRONT G.A.W.R.	= 20,000 LBS.
TANDEM G.A.W.R.	= 46,000 LBS.
YIELD STRENGTH OF EACH FRAME RAIL	MINIMUM SECTION MODULUS REQUIRED
120,000 P.S.I. YIELD	= 38.00 in. ³
MINIMUM RBM/RAIL = 4,560,000 IN-LBS	

NOTES:
 DOUBLE FRAME RAIL REQUIRED.
 FRAME RAIL MINIMUM OF 38.00 in.³ SECTION MODULUS REQUIRED.
 FULL SUBFRAME REQUIRED:
 4" x 2" x 3/8" RECT. TUBING (ON TOP OF RAIL)
 4" x 2" x 3/8" RECT. TUBING (CROSSMEMBERS)
 1/2" FULL WIDTH BOTTOM PLATE
 3/4" FULL WIDTH TOP PLATE
 LARGE CRANE FISH PLATES REQUIRED.
 CURB WEIGHTS WERE PROVIDED.

TRACTOR, HIAB CRANE AND ACCESSORIES WEIGHT DISTRIBUTION, MAX. LOAD AT FIFTH WHEEL.	
FRONT AXLE LOAD	= 18,520 LBS.
TANDEM AXLE LOAD	= 33,980 LBS.
FRONT AXLE PERCENTAGE	= 35 %
TANDEM AXLE PERCENTAGE	= 65 %
FIFTH WHEEL LOAD	= 8,690 LBS.
GROSS VEHICLE WEIGHT	= 52,500 LBS.

NOTICE:
 THIS WEIGHT DISTRIBUTION IS BASED ON ESTIMATED WEIGHTS AND IS ONLY AS ACCURATE AS THOSE ESTIMATES. ACTUAL WEIGHTS MAY CHANGE THE RESULTS OF THIS WEIGHT DISTRIBUTION.

NOTICE:
 THE DRAWING PURPOSE IS TO INTRODUCE A GENERAL CONCEPT OF A PROPOSED IDEA.

Cargotec USA
 Cargotec USA Inc.
 12233 Williams Road
 Perrysburg, Ohio 43551
 Tel (419) 482-6000
 Fax (419) 482-6001

Tolerances - unless otherwise noted.
 Tolerances are in inches
 2-PLACE 2.00..... .03
 3-PLACE 2.000..... .015
 ANGULAR 2 1/16"
 FRACTIONAL 2 1/16"
 Break all sharp corners unless otherwise specified.

THIS PROPERTY AND ALL INFORMATION THEREIN IS THE PROPERTY OF CARGOTEC USA INC., 12233 WILLIAMS RD, PERRYSBURG, OHIO 43551 AND IS CONFIDENTIAL. IT MUST NOT BE MADE PUBLIC OR COPIED. THIS DRAWING IS LOANED TO RETURN UPON DEMAND AND SHALL NOT BE USED DIRECTLY OR INDIRECTLY IN ANY WAY DETRIMENTAL TO OUR INTERESTS. OUR PRIOR SPECIFIC APPROVAL IS REQUIRED FOR EXPOSURE OF THIS DRAWING TO OTHERS FOR ANY PURPOSE.

Next Assy.
 Dwg/Cad file no.
658 / SALES

Drawing Title:			
HIAB 658EP-5 HIPRO			
Project Name:			
SALES LAYOUT			
Drawn by:	Date:	Size:	Part No.
CSV	3-30-17		
Approval:	Date Approved:	Scale:	unit wt.
			Eng. Job no.:

TRACTOR RUNS IN U.S. (RULES FOR MOST STATES)
 20,000 LBS. ALLOWED ON FRONT AXLE.
 34,000 LBS. ALLOWED ON TANDEM AXLE.
 52,500 LBS. ALLOWED FOR GROSS WEIGHT. (22')