

HIAB S-HIPRO 130

HIAB REFUSE COLLECTOR







REFUSE COLLECTION MADE EFFICIENT



EVERY KILO AND EVERY SECOND COUNT

Underground waste containers are gaining in popularity particularly in European cities. They are out of sight, prevent litter from blowing around and do not smell. Furthermore, their capacity can be up to 6 normal 1100 L bins, thus minimizing collection truck traffic in the increasingly busy cities. Emptying them is often a challenge, though. The efficient collection of refuse in busy city centres requires a streamlined and simple to use load handling tool, with a maximised payload on the truck – every kilo and every second count.



Collect up to 25% more waste with less effort

Collect municipal waste in cramped cities faster, safer, cheaper and more environmentally friendly with the Hiab S-HIPRO 130. The crane is mounted on top of the compactor rather than behind the cabin which saves space and creates room for a larger compactor. More waste can be collected in one tour, saving fuel and driving time. The crane is highly versatile and can be placed on many different compactors and vehicles.

- Maximise payload and volume
- Save valuable time in each load cycle
- Smooth operation for the driver
- Make refuse collection easier and safer

MAJOR BENEFITS

– Collecting household waste costs Amsterdam 50 to 60 million Euros every year. We have to cut costs. With the new solution we can improve our efficiency. It can help us work faster, cut fuel costs and emissions and reduce the inconvenience to others. We have expressed our willingness to Cargotec to talk about further refining the concept to make it perfectly suitable to the four largest cities in the Netherlands.

Senior civil servant for the city of Amsterdam.

4 m³ more compaction volume saves time

Waste containers are traditionally lifted with a crane that has been installed on the chassis behind the cabin. The installation claims a space of about one metre, limiting the size of the compactor to a maximum of 16 m³. By putting the crane on top of the compactor it is possible to increase compaction by 4 m³. Instead of the usual 9,000 kilograms of waste per tour this design lets you collect 11,000 kilograms – or about 12 bins more.

2 minutes is all it takes

Being semi-automatic, the crane offers both fast and accurate load cycles. In less than two minutes you will have emptied the bin and can move on to the next one. Parts of the load cycle are automatic, like unfolding and folding of the crane. Other parts are manual, like container pick up and container emptying. The crane can handle two, or even three, bins without repositioning the vehicle.

More waste per round saves fuel

The solution saves time with every load cycle and is gentler on the environment. In addition to the fuel saving when you can transport 20 to 25 percent more waste on every tour you also eliminate a significant number of trips to the transfer station – and also the number of collection trucks needed to pick up the same amount of waste.

Safer operation

A smart control system helps to further optimise fuel consumption, increases safety for both the surroundings of the vehicle and speeds up emptying the containers. The system features automatically operated stabilizer legs to maintain stability of the vehicle.

Cleaner environment, nicer cities

The hydraulic system is built up on load sensing hydraulic principle and is prepared for a variable pump. The system saves fuel and reduces emissions to the environment. Passers-by and the people dedicated to recycling their waste will most definitely enjoy the cleanliness of the site with its hidden, essentially odorless containers.



Compact dimension paves the way

Sitting on top of the compactor this slender crane makes room for a larger compactor. stipulated four meter to go under bridges and through tunnels.



Emptying containers

Some containers are opened at the top, others at the bottom. Some have one compartment; others two, or even three. There are clever and very safe tools for all emptying solutions. Ask your local Hiab representative for advice.



Keep track of the weight

A weighing system is used to get a rough weight indication or accurate weighing data for your business administration. Talk to your local Hiab representative to get the weighing systems that suits your needs.



Freedom at your fingertips

The ergonomically developed Hiab XSDrive relieves you of stress and strain in hands, arms and back. Load handling becomes both more efficient and safer since you can position yourself at the best possible location when operating the crane.

HIAB S-HIPRO 130

A user-friendly control system with Crane Tip Control (CTC)

With this advanced control system we have not only the possibility for a one-lever vertical lift but also the control over the horizontal movement with one other lever. The vertical lift is great when taking the underground container from the pit with accuracy making the job much easier. The system is well proven in other crane applications in the toughest conditions.

The speed and accuracy of a fine-tuned hydraulic system

The faster you can get the job done the better. This calls for high volumes of oil to move quickly – whilst keeping heat generation to a minimum. An oil cooler along with a fine-tuned hydraulic system does the trick; optimised hose and pipe routing, big hydraulic ports, pressure compensated and load sensing valve, optimised spools – and more. The result is a speedy crane and longer lifetime of the oil and hydraulic system.

High uptime with less maintenance and easy service

The hydraulic hoses are well protected within the boom system. This keeps maintenance costs down and increases productivity. The highly wear-resistant hoses have an impressively long service life and are easy to change.

Changing the hoses is extremely fast and can be done by a single person even in the field. The telescope is equipped with internal hoses for extra functions, for example a weighing system.

Load cycle

Start

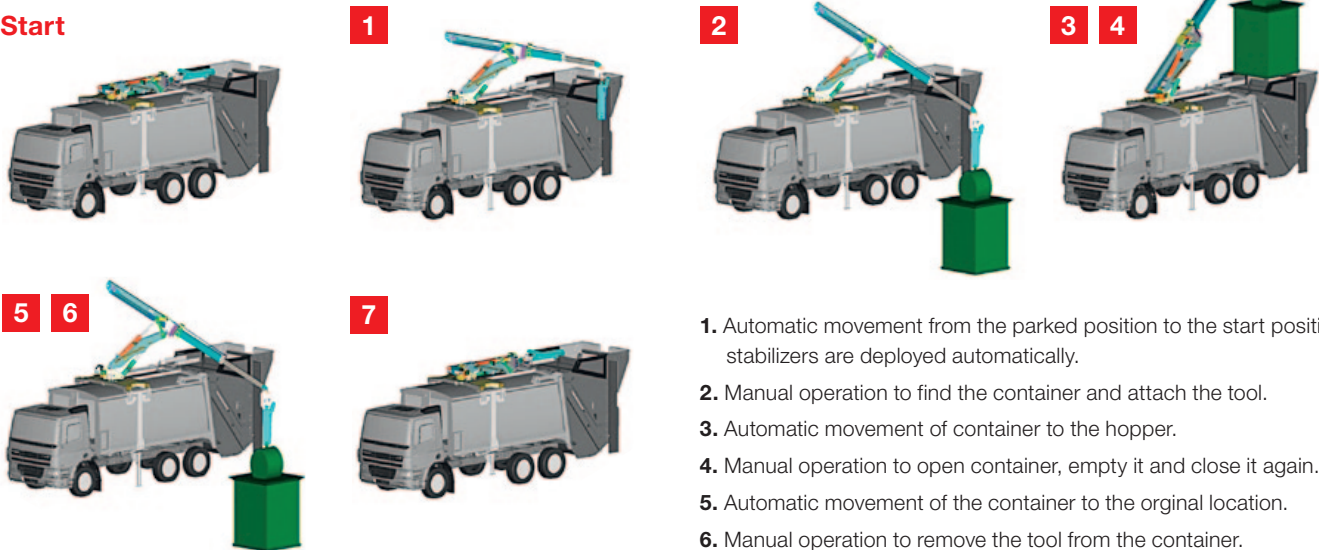

1. Automatic movement from the parked position to the start position, stabilizers are deployed automatically.
2. Manual operation to find the container and attach the tool.
3. Automatic movement of container to the hopper.
4. Manual operation to open container, empty it and close it again.
5. Automatic movement of the container to the original location.
6. Manual operation to remove the tool from the container.
7. Automatic movement to the parked position and stabilizers in.

Vertical lift



Reach diagram

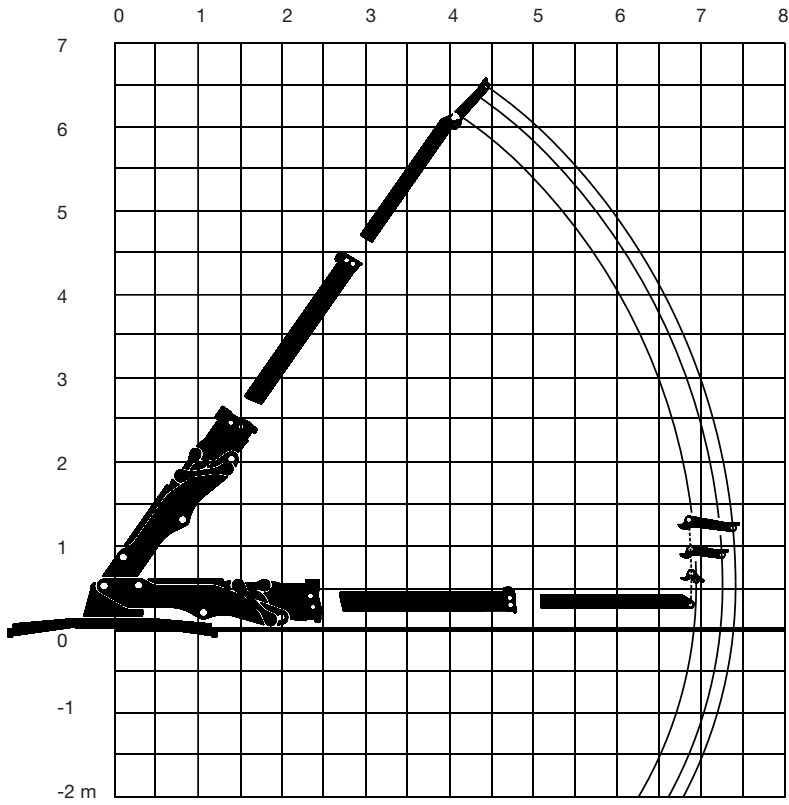

Load plate

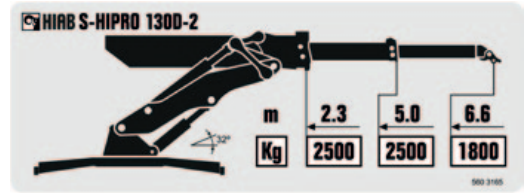

Side view folded position:

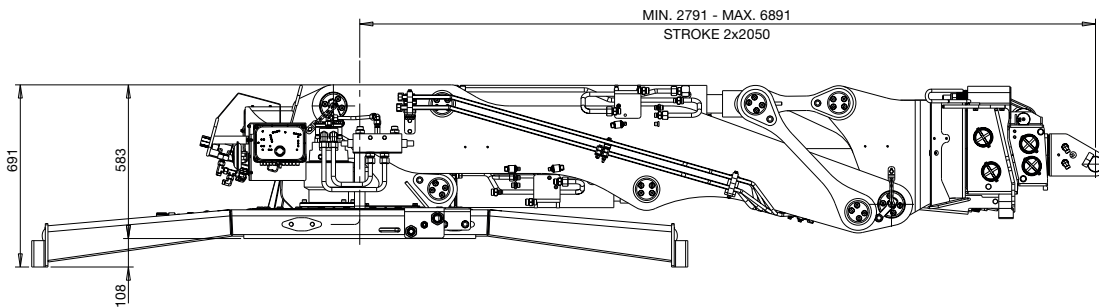

Top view folded position:

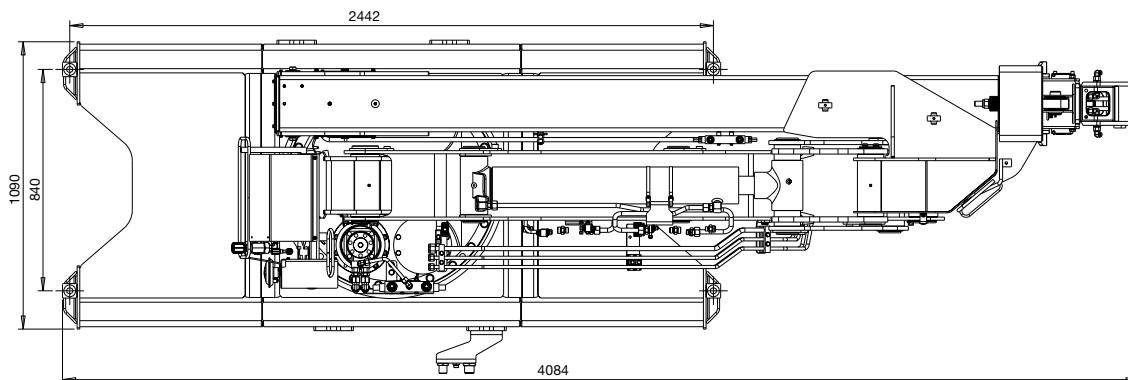



HIAB

DAF
75000



LET'S HELP YOUR CUSTOMERS — **TOGETHER**

Hiab is the global market-leading brand in on-road load handling solutions. Customer-driven Hiab on-road load handling products and solutions are utilised in moving goods and materials on the road, for example in construction sites, forests, industry, waste handling, recycling and by the defence forces.

Talk to your local sales person to learn more about what we can do for you. We're here to help.

THE LOAD HANDLING SPECIALISTS

Hiab is the world's leading provider of on-road load handling equipment. Our high performance product range includes loader cranes, forestry and recycling cranes, demountables, truck-mounted forklifts and tail lifts. We aim to set the industry benchmark for customer satisfaction by providing products and services that meet customer needs globally. Hiab's workforce numbers approximately 2,800 people.

www.hiab.com

Hiab is part of Cargotec. Cargotec's sales totalled EUR 3.2 billion in 2013 and it employs approximately 11,000 people. Cargotec's class B shares are quoted on NASDAQ OMX Helsinki under symbol CGCBV.

www.cargotec.com

