

HIAB



HIAB LOADERS AT WORK
CITIES & MUNICIPALITIES

HIAB LOADERS

UNMATCHED SAFETY, LONGEVITY & EFFICIENCY

Cities and Municipalities require versatile, reliable and safe equipment that can be counted on through all seasons. HIAB Loaders are the global industry leaders in the areas of safety & reliability and bring greater efficiency, a high lift capacity to low weight ratio and compact dimensions, Providing the speed and flexibility to streamline any operation.

With multiple model configurations to choose from, an array of attachment options and a variety of mounting configurations Hiab are able to offer a more specific solution to meet the demanding needs and safety requirements of any City & Municipality material handling.

HIAB ADDRESSES YOUR INDUSTRY PAIN POINTS

HIAB loaders deliver what the material handling industry expects: transformational safety, reliability, and performance. With a choice of different capacities and reach, both models offer increased payloads and thrive on intense load cycles. Built on proven technology, they set new standards in material handling – delivering important advantages to the forestry, railroad, and recycling industries.

SAFETY - HIAB Loaders are designed with industry leading safety features that keep operators safe and in control. Safety and stability are built into the material handlers without compromising their performance, and with additional safety options available, each will meet the individual needs of customers in the forestry, railroad and recycling industries.

EFFICIENCY - HIAB's advanced technology drives the performance of the equipment resulting in superior operation efficiencies. HIAB's class-leading products can not only be used by operators of different skill levels, but are also versatile with the ever-changing operational environment.

DOWNTIME - HIAB Loaders bring a longer service life to the material handling market. They are designed and constructed to thrive on high-intensity, heavy-duty work year after year. Day-to-day productivity is secured by HIAB's industry-leading nationwide service network and exceptional 2 years' full warranty plus 3 years' structural component warranty program.

TRAINING - Training and educating operators takes time, but the HIAB Loaders allow customers to manage their resources in the best way. With a local HIAB expert, customers have direct access to the manufacturer and are able to secure the highest quality training.

RELIABILITY - The HIAB Loaders are the industry leaders in the area of reliability. Our products are engineered to ensure optimum longevity and service life of your equipment. All backed up with the most comprehensive warranty in the market.

REVENUE - Combining durability and high productivity, the HIAB Loaders help lower operational costs and support consistent, efficient operations. With a proven design, quality materials, and industry specific innovation, investing in a HIAB Loader provides a total package for any industry.

FEATURES THAT BRING SOLUTIONS



The standard **E-stop** kit improves safety. One hit on the button stops all operations – just what you need in an emergency, such as hydraulic system failure. This option also includes operator indication for transport status of boom and stabilizers and operational status of capacity.



RZ models are equipped with **Overload Protection (OLP)** and bring an unprecedented level of **safety** to operations without reducing performance. When approaching an overload condition, the crane gives an audible and visual signal at 90% and will stop all radius increasing functions once full capacity has been reached.

For enhanced safety, HIAB Loaders can be equipped with **Load Holding Valves (LHV)** for boom systems and/or slewing. LHVs will keep the load safe and stationary in the event of damage to a hydraulic hose or connector.

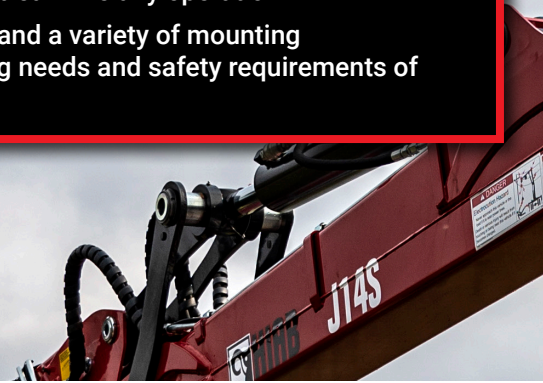



HIAB Loaders come standard with **“Out-and-Down” style stabilizers**, which offer wider span for better stability. Also, the stabilizer beam is separate from the loader’s base, allowing flexible installations, as it can be fitted either side of the base without structural modifications.



Hose Protection Link (HPL) incorporated with the internal boom hoses safely route the hoses to the boom tip and reduce the opportunities for impact damages. Hoses are also equipped with quick couplings for easy maintenance and replacement.

The column design offers use of **high-torque rack and pinion slewing** mechanism for more precise and efficient loader control. In addition, the double racks offer higher slewing torque capabilities for more efficient loading and better performance in uneven terrain. The slewing mechanism is lubricated constantly in an oil bath, increasing reliability and extending the loader’s working life.



HIAB Loaders are covered with an industry leading 2 year **full warranty** and 3 year **structural component warranty**, offering peace of mind and minimal downtime.



Built using high-grade steel and an optimized structural design, HIAB Loaders are both lightweight and long-lasting. Their structural design is engineered for an optimal weight to lift capacity ratio, offering heavier payloads paired with the strength and power to get the job done. This translates directly to better profitability for every load.



HIAB Loaders have a **Precision Hydraulic System** with a fixed pump, 2 circuit system. Its high pressure filtration and other operational characteristics, such as their control valve/spool design, create a smooth operation with high flow capabilities.

HIAB Loaders are equipped with **JIC hydraulic connections**, offering simple and reliable hydraulic fittings. Known industry standard without additional parts leading to secure coupling with mechanical tightening only and widely available.



HIAB Loaders top seat area has been designed with operator safety in mind. The operator area is surrounded with safety rails, and the **premium top seat** is comfortable, ergonomic, and easy to access. The seat has wide range of adjustments, allowing it to be adjusted to the ideal working position. All standard operations are at arm’s reach from the top seat, offering easy access to the stabilizer controls, truck start/stop, e-stop, and work light controls.



HIAB’s **nDurance™** paint is an anti-corrosion paint system using nano technology for the ultimate anti-corrosion coating, maintaining a rust-free **reliable** crane.



HIAB ProCare™ is a proactive preventative maintenance service contract, designed to **maximize uptime** of all HIAB equipment by maintaining proper service intervals.

We have invested heavily in our **Nationwide Service and Support** team as part of our commitment to our customers. With 28 branch locations and over 200 factory-trained mobile service technicians, your HIAB loader crane is protected with an unrivalled coast-to-coast service network, greatly reducing the **downtime** of your equipment, thus **reducing overhead costs**.

HIAB J14S / J1500RZ Technical Specifications

HIAB J14S

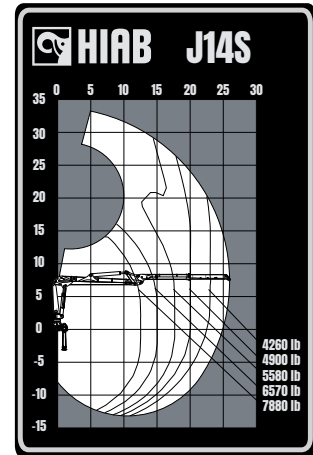
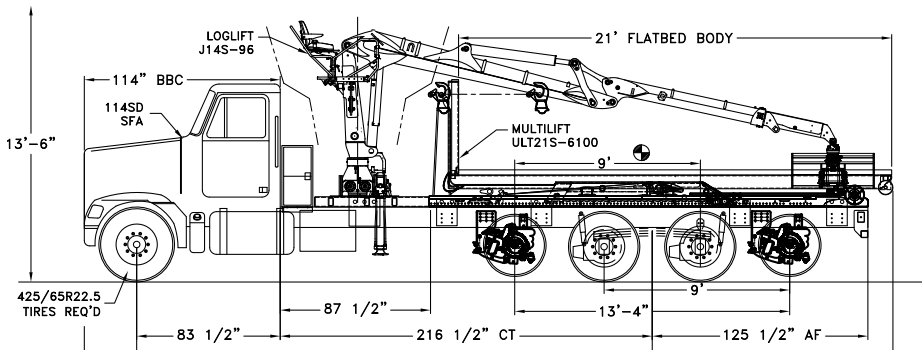

HIAB J1500RZ

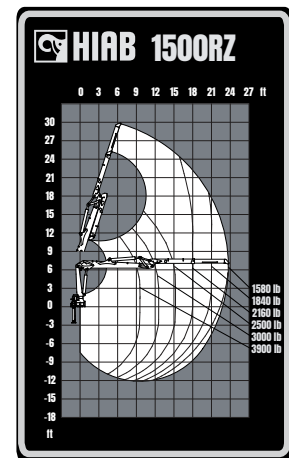
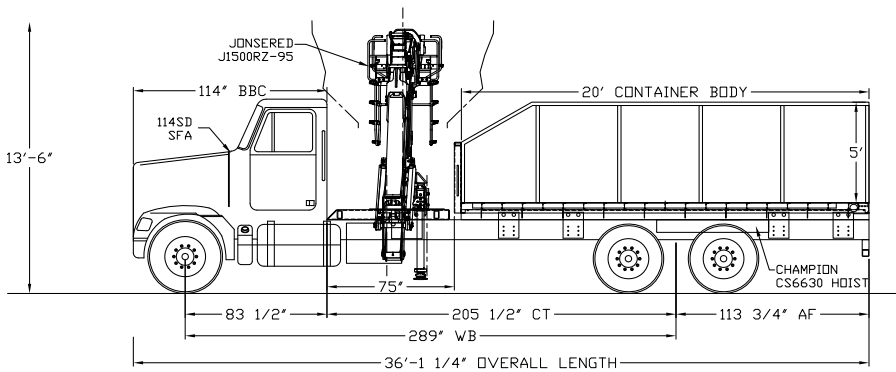

Our extensive stock of parts at our **Regional Distribution Center** ensures next-day delivery on almost all items, reducing **downtime** and **saving you money**. The same team you trust to deliver high-quality, premium products to your exact requirements can also be trusted to keep you moving.



HIAB's **Leading Warranty** exceeds the industry's standard terms because our products are designed to last longer and provide many years of **reliable** service.



HIAB loaders have a biodegradable oil option to protect the **environment** from contamination like traditional, mineral based oils. Additionally, the E-stop feature will immediately stop operations in instance of an oil leak.

HIAB USA LOCATIONS

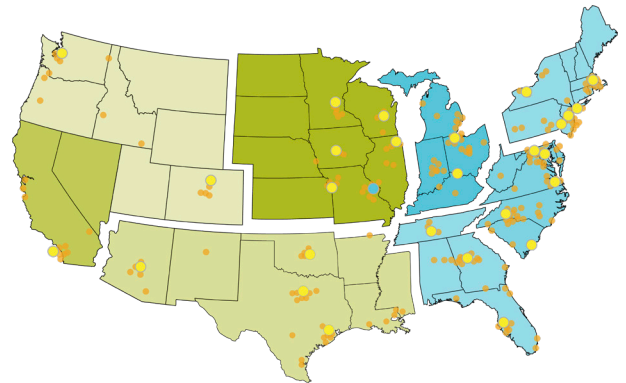

Our commitment to you

Hiab is the world's leading provider of on-road load handling equipment, intelligent services, smart and connected solutions. Hiab's class-leading load handling equipment includes HIAB, EFFER and ARGOS loader cranes, LOGLIFT and JONSERED forestry and recycling cranes, MOFFETT and PRINCETON truck mounted forklifts, MULTILIFT skiploaders and hooklifts, and tail lifts under the ZEPRO, DEL, and WALTCO brands. As the industry pioneer and with a proud 75 year history, Hiab is committed to be the preferred partner and solution provider to its customers and shape the future of intelligent load handling. www.hiab.com Hiab is part of Cargotec Corporation. www.cargotec.com

For all your sales and service needs, call our nationwide hotline at 419.482.6000 to find your nearest Hiab USA branch.



HIAB



Hiab USA Inc
12233 Williams Road
Perrysburg, OH 43551 USA
tel. +419 482 6000
www.hiab.us.com

