

Operator's Manual GB HIAB 322-377 HiPro CD

This operator's manual is an Original Instruction
and applies for cranes from serial number:
3221631, 3771320

2015-06

Congratulations with your new crane!

You are now the owner of a quality product from Cargotec, built to the highest standards of safety and quality.

The aim of this manual is to help you handle your crane safely and with full satisfaction.

Please read the complete manual. It provides detailed information about the crane, safety system and the practical management and maintenance of the crane.

We advise you to read it carefully and familiarize yourself with your crane before you start to use it.



Help us to improve this manual. Please send your comments and suggestions to **documentation@hiab.com**

Table of Contents

1.	Knowledge required.....	6
1.1	This Operator's Manual is intended for operators of this HIAB crane.	6
1.2	Indications in the Operator's Manual	7
2.	Structure and parts of the HIAB crane.....	10
2.1	Main groups	10
2.2	Crane base with column and slewing system	10
2.3	Boom system	11
2.4	Stabiliser system.....	13
2.5	Operating system - hydraulic components	14
2.6	LHV Load holding valves	14
2.7	Description of Hiab 322-377 HiPro CD.....	15
2.8	Accessories that can be fitted in a 322-377 HiPro.....	16
3.	Safety precautions and warnings.....	17
3.1	Operating conditions	17
3.2	Definition of a HIAB loader crane.....	18
3.2.1	Noise declaration.....	19
3.2.2	Warning signs	20
3.2.3	Maximum load.....	20
3.2.4	Maximum load moment.....	23
3.3	Signals when using a crane.....	26
3.4	Wind speeds	30
3.5	Use of the crane	31
3.6	Use of lifting equipment	38
3.7	Use of dismantable cranes	38
4.	The Safety system.....	40
4.1	Safety System SPACE 5000 with CombiDrive2.....	40
4.2	How the safety system works.....	40
4.3	Components of SPACE 5000 Safety System	42
4.4	Operating components	43
4.5	Main control valve.....	43
4.6	Stabiliser control valve	45
4.7	Extra stabiliser control valve [option].....	45

Table of Contents

4.8	Cranes with high seat [option]	45
4.9	OPS Operator Protection System [option]	46
4.10	User panel SPACE 5000	46
4.10.1	Indicator lights on user panel SPACE 5000	47
4.11	CombiDrive2	49
4.12	Main menus CombiDrive2	53
4.13	Battery charger CD2	60
4.14	Functions	61
5.	Starting crane operation	65
5.1	Starting operations	65
5.2	Extend stabiliser extensions and set stabiliser legs	69
5.3	Operate the crane out of parked position	75
6.	During operation	77
6.1	OLP (Overload protection)	77
6.2	BDA Boom Deployment Assistance [option]	80
6.3	Manual extensions [option]	80
7.	Ending crane operation	83
7.1	Operate the crane to parking position	83
7.2	Placing the stabiliser extensions and legs in transport position	84
7.3	Switching off the safety system	87
7.4	Emergency operation Valve-V91	88
7.5	TWI Transport warning interface [option]	89
8.	Maintenance and Service	91
8.1	Service	91
8.2	Warranty	92
8.3	Follow the maintenance instructions!	93
8.3.1	Daily inspection	94
8.3.2	Monthly inspection and maintenance	95
8.3.3	Annual maintenance	97
8.4	Lubrication	97
8.4.1	Lubrication schedule	98
8.4.2	Lubrication of slide pads in the boom system	99

Table of Contents

8.4.3	Lubrication of the upper column bearing	100
8.5	Hydraulics	100
8.5.1	Slewing housing: checking the oil level/oil change	100
8.5.2	Replacing the cartridge in return oil filter	101
8.5.3	Replacing the cartridge in the pressure reduction filter.....	102
8.5.4	Checking the oil tank level	102
8.5.5	Changing the hydraulic oil.....	102
8.5.6	Bleeding air from the hydraulic system	105
8.6	Troubleshooting.....	106
8.6.1	Main fuses	106
8.6.2	Faults in the HiPro crane	106
9.	Decommissioning.....	110
9.1	Decommissioning a crane	110
10.	Technical Data	112
10.1	Documentation	112

1.1 This Operator's Manual is intended for operators of this HIAB crane.

This manual describes:

- Operation
- Safety precautions and warnings
- The crane safety system
- Maintenance and troubleshooting

Enclosed to this manual the Installer will provide:

- Technical Data for your crane
- Technical Data and manuals for add on equipment if fitted

Study these instructions carefully



DANGER

If you do not study the complete Operator's Manual for your crane carefully, it could lead to fatal accidents or serious damage.

Therefore you should:

- Study the entire Operator's Manual carefully.
- Study the operating manuals for other add-on equipment, if fitted.
- Use the crane only after having done so.
- Follow the directions for use, operation and maintenance of the crane and add on equipment exactly.
- Store the Technical Data and manuals from the Installer, together with this Operator's manual.



! NOTE

The manufacturer reserves the right to change specifications, equipment, operating instructions and maintenance instructions without prior notice.



NOTE

HIAB shall at all times have the right to:

- install, maintain and dismantle automated remote diagnostics system or similar sensor-based system (the “System”) in and from the Equipment; and
- access, send, receive, collect, store and use any and all information and data gathered or created by such System including but not limited to information concerning operation, operating environment, movement, condition, logon, location and similar information relating to the Equipment (the “Information”).

The Customer shall not in any way remove or alter the System, nor interfere with the use of the System or the Information. The System and the Information and all their further developments shall at all times be and remain the exclusive property of HIAB without granting any right or license to the customer.

1.2 Indications in the Operator’s Manual

What must you do and not do?

The following indications are used in the Operator’s Manual:



DANGER

Danger to life for yourself or to bystanders.
Follow the instructions carefully!



WARNING

Danger of injury to yourself or to bystanders, or danger of serious damage to the crane or other objects.
Follow the instructions carefully.



**CAUTION**

Hazard for the crane or crane components.
Follow the instructions carefully.

Important:

If actions are numbered

1. Do this
2. Do that
3.
4.
5.

you should carry them out in numerical order!

**! NOTE**

Extra information that can prevent problems.

**TIP**

Tip to make the work easier to carry out.

Symbol for reference to a component in an illustration.

① Refers to a component in an illustration.

[option]: Indication for parts that are not-standard for the crane, but are an option.

**DANGER**

Only persons with the requisite knowledge and experience with cranes may use the crane.
Never operate the crane when you are sick, tired, under the influence of medicines, alcohol or other drugs.

- Take the delivery instructions from your HIAB Service workshop, or receive instruction from an experienced person from your own company. Only then should you operate your crane.

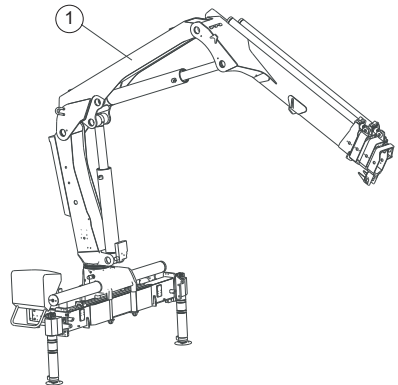

- Ensure that you comply with the statutory requirements of the country in which you use the crane (for example, certificate, obligatory safety-helmet).



DANGER

- Carry out yourself only the service and maintenance work you have the requisite knowledge and experience of.
- All other maintenance work may only be carried out by a HIAB service workshop.
- Ensure that every defect is rectified immediately, according to the instructions.
- Follow the instructions exactly!
- All other work to rectify faults must be performed by personnel in a HIAB service workshop!



WARNING

- Never clean the electronic system, plastic components, signs or bearings with a high-pressure jet cleaner. It could cause damage.
- Never expose the electronic system to high electrical voltages. This could damage the safety system.
- Never immerse the controller in water or other liquid. This will make the controller unusable.

If your crane is equipped with add-on lifting equipment (hoist, rotator, etc.):

- The operation of the crane with add-on lifting equipment can differ from the operation as described in this manual.
- You should therefore study the Operating Manual for the add-on equipment carefully, before you use the crane.
- Take particular note when placing the crane in to or out of transport position.

2.1 Main groups

The HIAB crane consists of the following main groups:

- Crane base with column and slewing system
- Boom system
- Stabiliser system
- Operating system

2.2 Crane base with column and slewing system

The crane base, column and the slewing system consist of the following components:

- Crane base
with stabiliser beam, column bearings and three-point bridge.
- Column
this fitted to the crane base and turns in an upper and a lower bearing.
- Slewing system

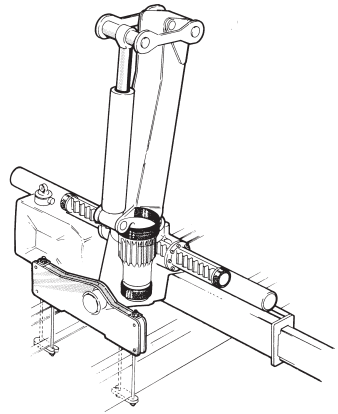

2.3 Boom system

The boom system consists of the following components:

- 1st boom ①
- 2nd boom ②
- Hydraulic extensions ③

The length of the hydraulic extension depends on the type of crane.

- Manual extensions ④ [option]

These are slid by hand into the hydraulic extension.

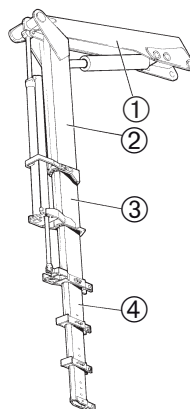

- **JIB [option]**

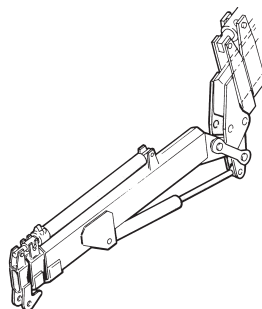

- **Add-on lifting accessories [option]**

Add-on lifting accessories are placed between the boom tip and the load (e.g. brick grapple, rotator) or on the crane (hoist).

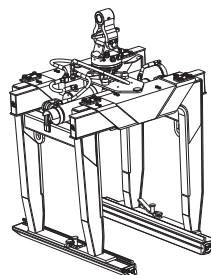

Separate lifting accessories [option]

Separate lifting accessories, help to make or use a slinging device: eye-hooks, shackles, eye-bolts etc.

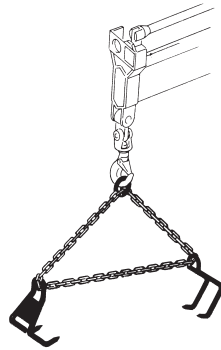

2.4 Stabiliser system

Every HIAB crane is equipped with two stabiliser extensions and two stabiliser legs. Auxiliary stabiliser systems may be needed for heavy cranes.

- Stabiliser beam ①. The stabiliser beam is a part of the crane base.
- Stabiliser extensions ②. The stabiliser extensions are hydraulically slid out from the stabiliser beam.
- Stabiliser legs ③. Place the stabiliser legs on firm levelled ground to support the crane.
- Stabiliser locking device ④.
- Support plates ⑤. The support plates are used under the stabiliser legs for additional support.

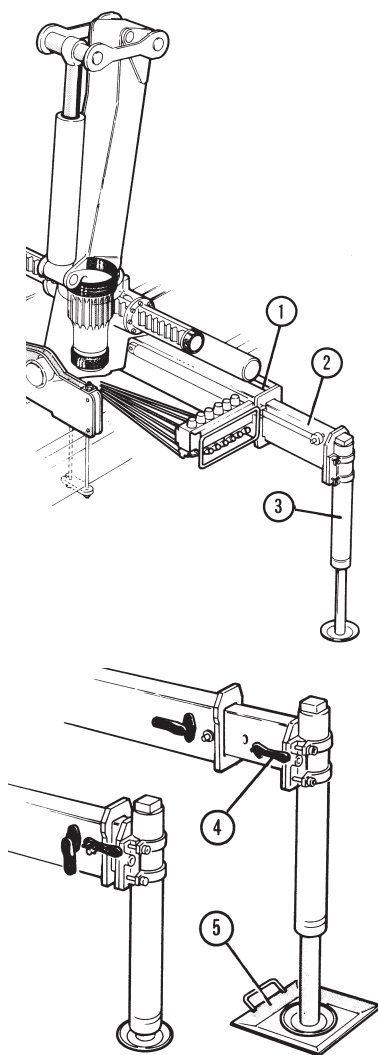

2.5 Operating system - hydraulic components

The operating system consists of the following hydraulic components:

- oil tank
- hydraulic pump
- oil cooler [option on some cranes]
- main control valve
- stabiliser control valve [option on some cranes]
- hydraulic hoses and lines
- actuators:
 - first boom cylinder
 - second boom cylinder
 - extension cylinder/s
 - slewing cylinders / motor reducers
- return filter
- pressure filter [option]

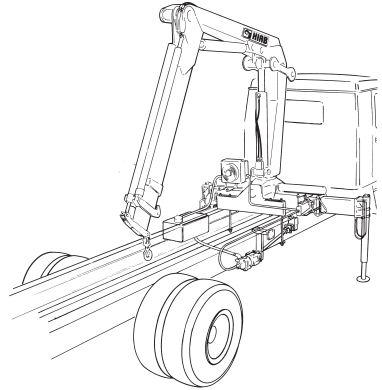

2.6 LHV Load holding valves

All cylinders are equipped with load-holding valves as a safety device. After a crane movement they hold the crane in position, also in the unlikely event of a burst hose.

If there is a leak or a component fractures, such as a pipe, hose or a coupling, the load-holding valves will stop the booms from collapsing down, even when the hydraulic system is switched off, and you operate a particular crane function.

To operate a hydraulic cylinder equipped with a load holding valve, an opening pressure is required.

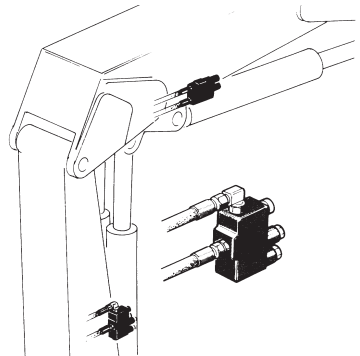

2.7 Description of Hiab 322-377 Hi-Pro CD

The HIAB 322 and 377 are compact, fully hydraulically operated goods cranes.

- HIAB 322 = 31.5 tonne metres
- HIAB 377 = 35.8 tonne metres

The cranes are supplied in many versions from:

- HIAB 322/377E-4 (reach 11.7 metres) to HIAB 322/377E-8 (reach 21.0 metres)
- HIAB 322/377EP-2 (reach 8.0 metres) to the HIAB 322/377EP-5 (reach 15.1 metres)

The main control valve V91, CombiDrive2 and the SPACE 5000 safety system are standard equipment on the HIAB 322/377 HiPro CD.

The crane type and the manufacturer are marked on the serial number plate.



! NOTE

The exact technical information for your crane is shown in the Technical Data.

2.8 Accessories that can be fitted in a 322-377 HiPro

Manual extensions	available in combinations:
1 and 2 manual extensions in crane	322/377 EP-2/3/4/5 + 1 322/377 E-4/5/6/7/8 + 1
	322/377 EP-2/3/4 + 2 322/377 E-4/5/6/7 + 2
1 manual extension in JIB	322/377 E-5/6 + JIB 70X-2/3/4 + 1

Hoists	available in combinations:
TC1 mounted on JIB (Not compatible with manual extensions in JIB, except: JIB 70X-4)	322/377 E-5/6 + JIB70X-3/4 + TC1
	322/377 E-4/5 + JIB100X-4/5 + TC1
TC2	322/377 EP-2/3/4/5 + TC2
	322/377 E-4/5 + TC2
TC2L Not compatible with manual extensions in: - 322/377 E-5/6 - 377 E-8 - JIB 70X-3	322/377 E-6/7/8 + TC2L
	322/377 E-5/6 + JIB70X-3/4 + TC2L
	322 E-5/6 + JIB75X-4 + TC2L (Only available in MEWP version)
Snatch block for TC2 and TC2L	322/377 E-4/5 + JIB100X-4/5 + TC2L
	Available in all combinations, except in the configuration 322 E-8 Not compatible with manual extensions

JIBS	available in combinations:
70X	322/377 E-5/6 + JIB70X-2/3/4
75X	322 E-4/5 + JIB75X-3/4 (Only available in MEWP version)
	377 E-4/5/6 + JIB75X-3/4 (Only available in MEWP version)
100X	322/377 E-4/5 + JIB100X-2/3/4/5

3.1 Operating conditions

You may only use the crane under the following conditions:

- In the open air, or in spaces with sufficient ventilation.
- With a mean wind velocity less than 13.3 m/sec (approx. 29.7 mph). **See the wind speed table.**



DANGER

- If you use the crane in a confined space you could suffocate from the exhaust gases from the vehicle.
- Never use the crane in a high wind or storm. When the mean wind velocity exceeds 13.3 m/sec (approx. 29.7 mph) the crane will behave unpredictably. **Never** use the crane during a thunderstorm.
- **Never** use the crane at temperatures below -40°C (-40°F), as the steel's properties deteriorate below this temperature.



WARNING

- At temperatures below 0°C (32°F):
Do **not** touch the operating levers during the first few minutes.
- When starting in cold weather, the wear on the hydraulic system is greater than at normal working temperatures.

To get a good function of the crane, it should be started as follows:

- Engage the power take-off at low rpm.
- Allow the system to idle for a few minutes.
- Operate stabiliser legs up and down for one minute, in order to warm up the oil.



3.2 Definition of a HIAB loader crane

Usage of the crane

The HIAB loader crane is used to lift and move loads in the working area permitted by the load plate and the load diagram. The cranes are normally mounted on a vehicle but they can also be mounted on a fixed base plate. The crane can be equipped with a number of accessories.

Loader cranes are designed for loading and unloading the vehicle, as well as for other duties as specified:

Permitted duties:

- Loading and unloading cargo from/to a vehicle
- Lifting of loads from the ground/vehicle to a higher place
- Installation work (beams, concrete plates, windows...) in building constructions
- Lifting construction material (wall boards, bricks, blocks...) on a pallet fork to a building, taking the material from the vehicle on which the crane is mounted, from another vehicle or from the ground
- Hoisting, e.g. beams, concrete plates and any other material and equipment used in building construction
- With a bucket, moving filling material at a construction site
- Handling large loads (containers, boats, machinery, vehicles...)
- Collection of waste and recycling material (glass, paper, cardboard, plastic...)
- Installation of informative posts, road signs, notice boards, traffic lights, street lights...
- Handling submerged pumps in wells, using a hoist

Forbidden duties:

- Crane mounted onboard ships or floating structures, only permitted in cases authorized by HIAB
- Continuous use as a production crane in assembly lines, foundries..., except for cranes prepared for that purpose
- Handle loads, work with submerge boom system or accessories, in strong currents such as rivers
- Loading cargo that is partially loaded or fastened by other means, without making sure the capacity of the crane is enough for the entire load
- Any duty which implies:
 - Pressure against the ground, unless the crane is specifically prepared for this
 - Push/pull with the boom system against any type of obstacle (wall, ground...)
 - Using the JIB upside down [HiPro cranes], except JIBs prepared for that. (See Operator's Manual for your JIB).

3.2.1 Noise declaration

The following values for emitted noise may be taken as general and conservative values for ordinary installations of loader cranes on normal diesel engine powered trucks. Declared dual-number noise emission values in accordance with ISO 4871:

- Emitted A-weighted sound power level for basic loader cranes in accordance with ISO 3744: $L_{wA} = 103$ dB (Uncertainty: $K_{wA} = 2$ dB)
- Emitted A-weighted sound power level for loader cranes with hoist in accordance with ISO 3744: $L_{wA} = 107$ dB (Uncertainty: $K_{wA} = 2$ dB)

Your crane has a certain lifting capacity, expressed in kNm or tm. This lifting capacity is also known as the load moment. The lifting capacity is: the payload at hook multiplied by the outreach in metres that the crane can operate at different positions. The lifting capacity of your crane determines the maximum load your crane may lift within its working zone. However take careful note; the greater the operating radius of the crane, the lower the lifting capacity will be because of the weight of the boom system itself. The load plate and the load diagram on your crane show the maximum loads you may lift in the operating reach of your crane.



DANGER

- Overloading could result in damage to the crane or in the worst case, personal injury or death
- Never increase a hanging load, since that may cause a load holding valve to open and/or the vehicle to turn over.
- Never use the crane with the OLP system switched off.

! NOTE

The extra weight of the lifting accessories has to be added to the load. Thus, with lifting accessories the load you can lift is less heavy

Load plate

You will find the load plate next to the control valve. On the plate is the maximum weight that you may lift at a given reach, with the 1st boom in the optimum position. In chapter Technical Data in this manual you will find these values for your crane.

Reach (m)	2.6	4.2	5.9	7.9	10.1	12.5
Capacity (kg)	9400	6000	4250	3200	2420	1900

Optimum position

The weight that your crane can lift will be determined by:

- stabiliser extensions positioned and legs pressed to ground.
- The reach at which you are working and the optimum position of the boom.
- The optimal position for your crane is on the load plate.



DANGER

Never exceed the maximum weight on the load plate.

Load diagram

The load diagrams are placed on the column and show the maximum loads your crane / JIB (if fitted) / hoist (if fitted) may lift in the entire working zone (manual extensions excluded). The load diagram drawing will also be found in the enclosed Technical Data.

The white area is the working zone of the crane.

The load curves show the maximum load that may be lifted at a given reach and height. For a given maximum load, the possible working zone is to the left of the load curve. The lifting capacity for some cranes is limited in the high lifting area.

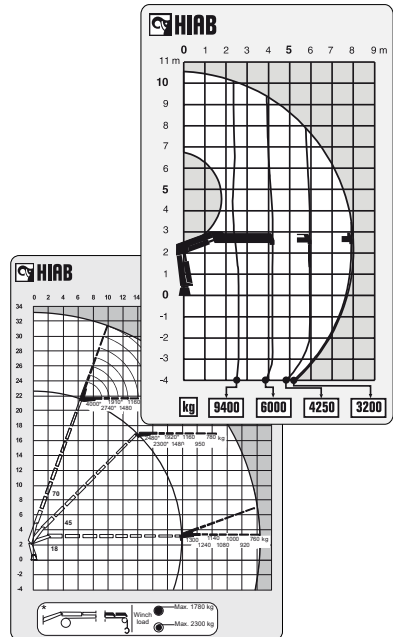



WARNING

Care must be taken when handling loads in the high lifting area, so the load/tool does not come into contact with the boom system.



WARNING

Never operate the hydraulic extensions against a solid object when the first boom is completely lifted. Do not try to push or compress loads when the first boom is fully lifted, as this could cause damage to the first boom cylinder.

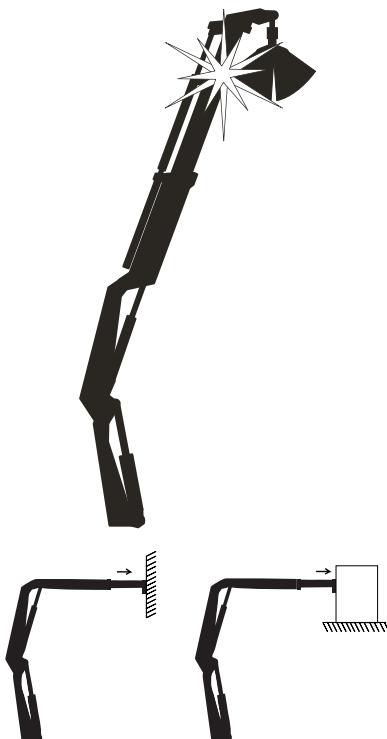

3.2.4 Maximum load moment

If your crane has reached the maximum load moment (lifting capacity), the OLP gives a warning and locks any crane movement that will increase the load moment. This is known as an OLP situation.

If the second boom is raised, then the following movements are locked:

- first boom down/up
- second boom down
- extension boom out

If the second boom is down, then the following movements are locked:

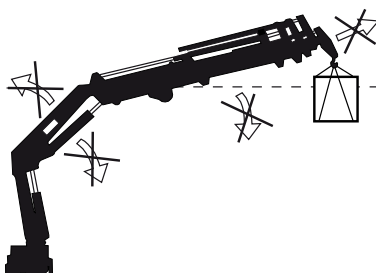

3.2.4

Safety precautions and warnings

- first boom up
- second boom up
- extension boom out
- first boom down (certain crane types and cases)

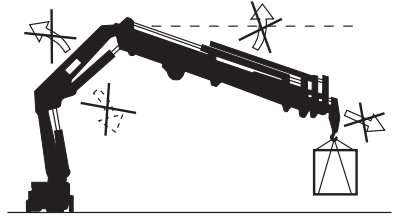

Lifting the load

You obtain the best from your crane in this way: Ensure that you always have the work in clear view. If you cannot see the load properly, you could cause a fatal accident or serious damage.

Sling length

Always attach the load using the shortest possible sling. The angle between the legs of the sling must not exceed 120° . The maximum working load (usually known as the working load limit (WLL) in standards) of a multilegged sling for general purposes is calculated by multiplying the WLL of a single leg by a mode factor, in accordance with the table.

Max angle to the vertical of any sling leg (degrees)	Mode factor two legged sling	Mode factor three and four legged sling
0-45	1,4	2,1
45-60	1,0	1,5

If the angle between the legs of the sling exceeds 90° , the slings should not be hung directly on the hook, but rather be slung from a ring that is hung on the hook.

Working close to the load

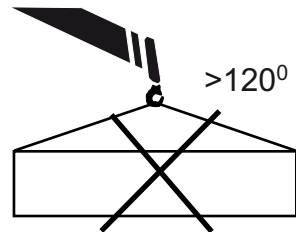
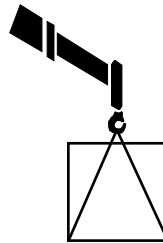

Always try to lift the load with the extension boom retracted, however not completely. The crane then has the greatest lifting capacity. Place the vehicle as close as possible to the load.

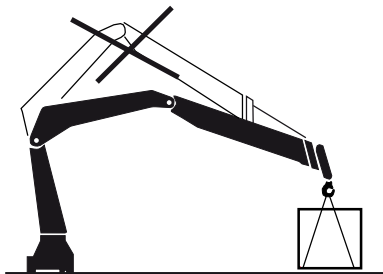

Working below ground level

If you have to load or unload below the level of the ground: keep the first boom angle to about 10 to 30° above the horizontal plane.

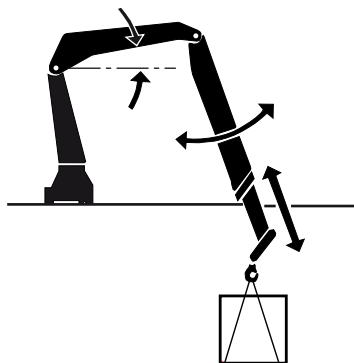

Heavy loads

Lift heavy loads with the second boom in the optimum position in relation to the first boom. For this, see the load plate on your crane.

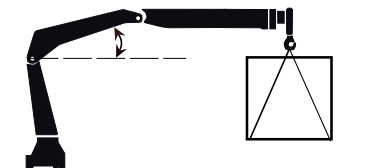

DANGER

Never exceed the maximum permissible loading of the hook.

Heavy loads cannot be handled with the boom straight.

Set the second boom, so there is an angle in relation to the first boom.

Loads at the extreme limit of the working zone

Also in this case, angle down the second boom somewhat. Only use the first boom .

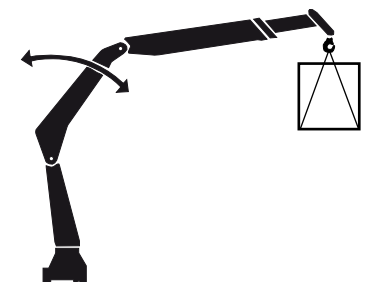

**TIP**

Make smooth crane movements: operate the crane with various functions simultaneously. In this way you will also prevent the hydraulic system heating up quickly.

3.3 Signals when using a crane

**DANGER**

- If it is not possible to see the load and the entire working area clearly the crane operator is obliged to follow the instructions and signals given by a qualified person qualified.
- The country-specific regulations for crane operator signals are to be used.

Signals in this manual give a number of standard signals that can be used.

Lift

Raised arm and index finger raised. Circular motion with hand.

**Lower**

Arm pointing downwards and index finger down. Circular motion with hand.



Stop all crane movements

Also: **Hold the load in position.**

Raise the open hand, with the palm clearly visible, and arm at shoulder height.

Keep the hand still.

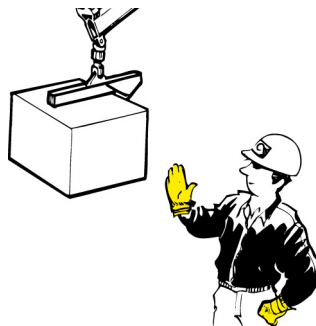

Emergency stop for all movements by the crane.

Raise the hands and the arms to an oblique angle.

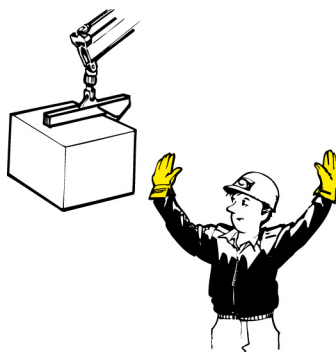

Very short movement

Place the hands a very short distance apart, with the palms facing each other. The hands may be held either horizontally or vertically. The next movement may be: Lift, lower, move the lifting gear, change the reach, or turn.

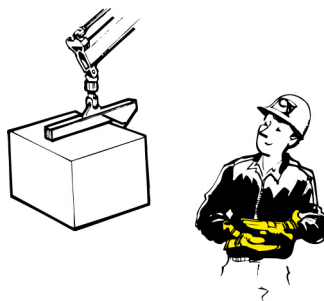

Change the reach

Signal with your hands.

- Sideways movement outwards with both hands. Thumbs outwards.
- Sideways movement inwards with both hands. Thumbs inwards.

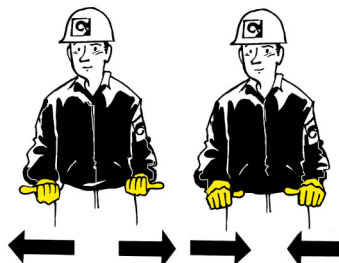

Turn in the direction indicated

Indicate the direction with the hands.

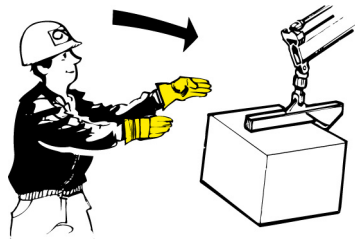
**Open the grapple**

Extend the arms at shoulder height, with the palms facing downwards.

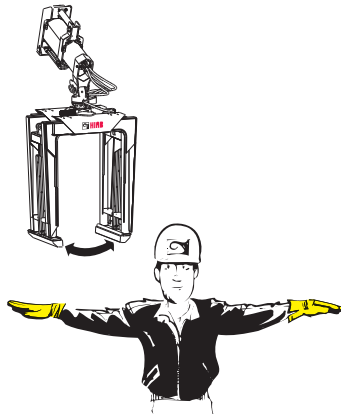
**Close the grapple**

Move both hands close together.

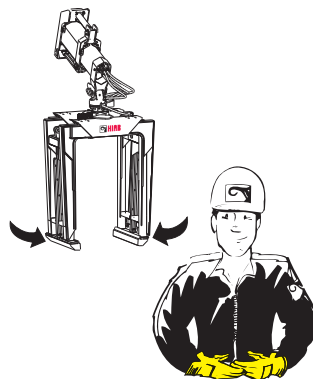

Lift the open grapple a little

Extend both arms at shoulder height, with the palms facing upwards. Make vertical movements with both arms outstretched.

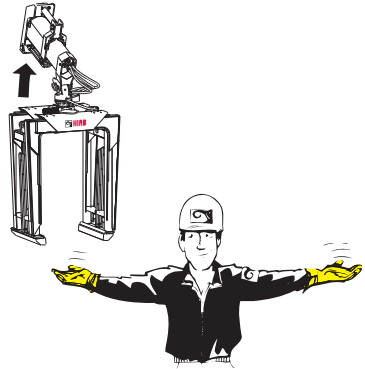

Keep the grapple in position briefly

Raise the hand drooping slightly, with the fist clenched.

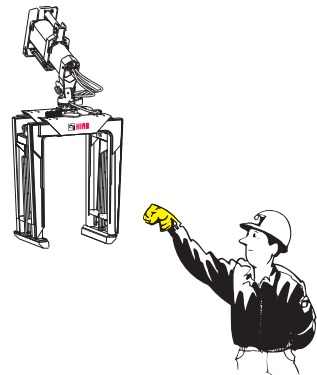

3.4 Wind speeds

Wind speed averaged over 10 minutes at a height of 10 m

Wind Force	Above flat ground		Characteristics
	m/s	Wind type	
0	0.0 - 0.2	Calm	Calm, smoke rises vertically or nearly vertically
1 2	0.3 - 1.5 1.6 - 3.3	Slight breeze	Wind direction recognisable from smoke plumes, the wind begins to be noticeable on the face; leaves begin to rustle and weather vanes can start to move.
3 4	3.4 - 5.4 5.5 - 7.9	Moderate wind	Leaves and twigs in continuous movement, small branches begin to move. Dust and paper begin to move over the ground.
5	8.0 - 10.7	Fairly strong wind	Small leaved branches make swaying movements; crested waves form on lakes and canals.
6	10.8 - 13.8	Strong wind	Large branches move; you can hear the wind whistling in telephone wires; umbrellas can only be held with difficulty.
7	13.9 - 17.1	Severe wind	Entire trees move; the wind causes difficulty when you walk into it.
8	17.2 - 20.7	Stormy wind	Twigs break off, walking is difficult.
9	20.8 - 24.4	Storm	Causes superficial damage to buildings (chimney pots, roof-tiles, and TV antennae are blown off).
10	24.5 - 28.4	Severe storm	Uprooted trees; considerable damage to buildings etc. (occurs infrequently on land).
11	28.5 - 32.6	Very severe storm	Causes extensive damage (occurs very infrequently on land).
12	> 32.6	Hurricane	

3.5 Use of the crane

Starting crane operation



DANGER

- Wear a safety helmet (compulsory in some countries!).
- Check that the ground is sufficiently flat and firm.
- To ensure that the vehicle stays in its position, always engage the parking brake and place chocks under the wheels.
- Check that the ground is not undermined. Look out for sewers, cellars, excavations etc.
- The stabiliser legs must not be able to sink in! Use support plates that are large and firm enough for your crane. The plates must not bend under load.

Check that the support plate as, it comes under load, is not pushed into the ground.

- Ensure you can see the stabiliser legs and stabiliser extensions when you are operating them.
- Do not lower the stabiliser legs on the edge of an embankment, soft shoulder, slope etc.

Lower the stabiliser legs only on to a flat and firm surface.

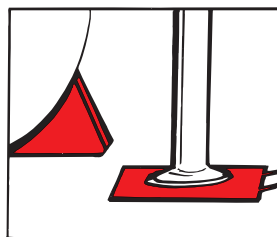

**DANGER**

- Do not stand in front of the hydraulically operated stabiliser legs when you are operating them!
- Never use the stabiliser legs as a parking brake, since the vehicle could start to slide.
- Slide the stabiliser extension, on both sides of the vehicle, out completely if possible. Then lower the stabiliser legs for support.
- Never operate the stabiliser legs, while the crane has a load!

**WARNING**

- Use low force when placing the stabiliser legs on the ground.
- Do not raise the vehicle with the stabiliser legs, if the crane is equipped with only two stabiliser legs!

If you raise the vehicle with the stabiliser legs, this may damage the stabiliser legs.

- Check that the add-on lifting accessories and separate lifting accessories are in good order!

Add-on lifting accessories are sometimes fitted on the crane (hoist, JIB) or placed between the boom tip and the load (grapple, rotator).

Separate lifting accessories are connected to the standard load hook (slings, chains, shackles etc).





DANGER

Do not stand in front of the boom system when operating the crane out of parking position.



Preparations for use



DANGER

Ensure that there are no unauthorised persons within the operating range of your crane!



TIP

Mark out the working range, e.g. with cones.
Put on your vehicle's warning lights.

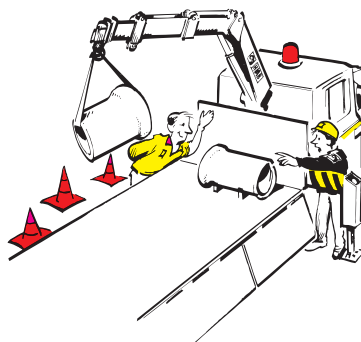

**DANGER**

- If a part of the crane comes in contact with an electricity line, you will be electrocuted!
- Maintain the following minimum distances between the crane and overhead electricity lines, unless otherwise prescribed by national rules.

Minimum distance between crane and overhead electricity lines

Voltage (V)	Minimum distance to an insulated conductor	Minimum distance to an un-insulated conductor
<500 V	0.5 m	2 m
500-40000 V	1.5 m	4 m
>40000 V	2.0 m	6 m

Voltages are found:

up to 500 V:	to buildings
500-40000 V:	trams, trains
over 40000V:	power transmission

Crane operation**DANGER**

Your crane has a safety system.

The safety system will help you to work safely. Nevertheless, you remain responsible for safe use of the crane!

Therefore, always work according to the operating instructions!

In an emergency immediately switch off all crane movements!

- Press a **stop button**.

To avoid unexpected load movements and at every interruption in crane operation.

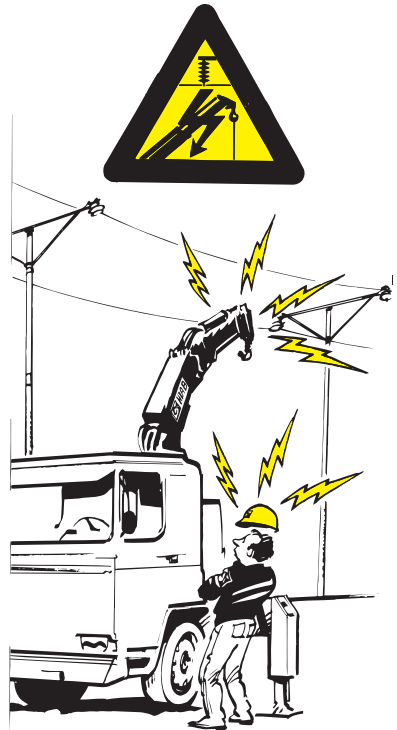

**DANGER**

- Keep checking that there are no unauthorised persons within the operating reach of the crane!
- Make certain that you can always see the load!

If your view of the load is not adequate, have someone else give you signals.

See the list of signals. Make certain that you and the person assisting you know these signals.

- Pay attention to the safety of the person giving the signals!
- Never move the vehicle, if you have a freely-suspended load on the crane!
- Never walk or stand under a suspended load!

During operation, never stand below the boom system or load!

- Do not slew the crane, nor lift the first boom, nor lift the second boom into their ends positions at full speed. This can damage the crane.



**WARNING**

- Never push a load along the ground, or the vehicle's load space, with the extension boom. This can cause damage to the boom system. This will lead to expensive repairs.
- Never use the extension boom as a jack. This could damage the slewing bearings and the connection between the crane column and the crane base.
- Always lift the load from the ground before you start to slew. Do not tow the load over the ground. This can damage the boom system.
- If you are working with loads in restricted spaces (for example, windows):
Check that the boom system can move up and down freely.
The boom system will bend somewhat, when loading and unloading the crane.
- If the boom system is in a high position (first boom above 70°), do not allow the boom to lower at full speed. The crane could go into an uncontrolled movement.
Be careful if, in particular, the OLP gives an early warning!
- When loading the vehicle:
Take the load off the stabiliser legs by withdrawing them slightly. The stabiliser legs must remain in light contact with the ground.

**CAUTION**

- Operate the crane using smooth and gentle lever movements.
- If a cylinder is at its end position, free the operating lever. Otherwise overheating can occur.

Driving with the crane



DANGER

- Never drive the vehicle if there is a load suspended from the crane.
- Before you move the vehicle:

Check that there is no pump flow to the main control valve. The PTO or power supply must be disengaged. The operating system must be switched off!
- Pay attention to the width and height of the crane in the transport position. The crane has to stay within the width of the truck. Make sure the stowed crane can not hit bridges, tunnels etc.
- Pay attention to overhead power lines! Make sure that no part of the crane ever comes in contact with overhead power lines.

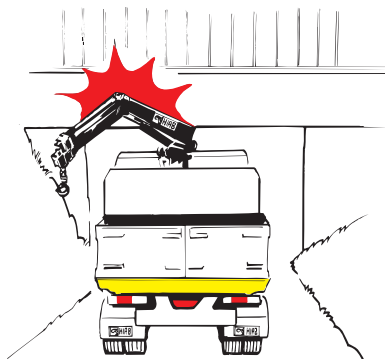

For further instructions see vehicle's manual(s).

Ending crane operation



DANGER

Always end crane operation as follows:

- After use, always place the crane in the transport position!
- Withdraw the stabiliser legs and stabiliser extensions.
- Check that the locking mechanisms are properly locked.
- Switch off the operating system.
- Disengage the PTO or power supply after work.
- If you drive with the PTO or power supply engaged, this will cause serious damage to the PTO/gearbox combination.
- Only after doing the above, should you drive the vehicle away.

3.6 Use of lifting equipment



DANGER

- Only use lifting accessories (hoist, grapple, rotator) that are suitable for your crane. Contact a HIAB service workshop.
- Never attempt to install add-on lifting accessories yourself!
- Add-on lifting accessories may only be installed by an authorised HIAB service workshop.
- When using lifting accessories, follow the instructions supplied with the equipment!
- Watch out for hazards!
- Never try to adjust lifting accessories when you are working on the crane!

After the lifting accessories have been fitted:

1. Check that the lifting accessories are securely fixed.
2. Only after this should you use your crane.

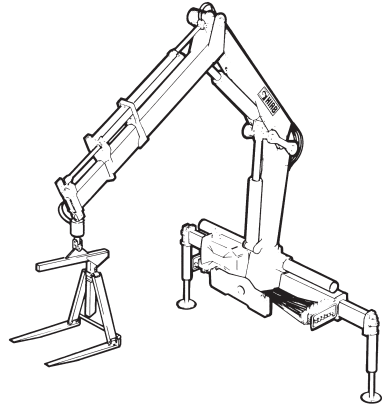

WARNING

- Clean the couplings, when connecting and disconnecting lifting accessories. Dirt can damage the hydraulic system.
- Take care that your fingers are not trapped

3.7 Use of dismantlable cranes



DANGER

- Ensure that there are no unauthorized persons in the immediate vicinity of the crane. When mount/dismount the crane to the vehicle people can suffer fatal crushing injuries!
- After setting up:
Check that the crane is properly locked!



WARNING

Take care when mounting/dismounting the crane on/off the vehicle.

Roughly handling can seriously damage the crane or the vehicle.

4.1 Safety System SPACE 5000 with CombiDrive2

SPACE 5000 is a version of a crane safety system.

With the remote control CombiDrive2 you can control the crane at a distance.

The safety system:

- Monitors the crane's operation and prevents unsafe actions.
- Increases the precision with which you can work.
- Makes operation easier.
- Makes troubleshooting easier.

SPACE 5000 is used on cranes with main control valve type V91 and remote control CombiDrive2.

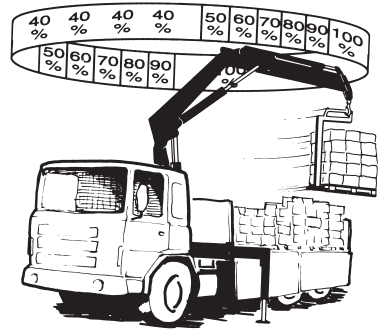

Crane version	Control Valve	Safety system
HiPro CD	V91	SPACE 5000



! NOTE

The safety system provides a large number of functions. Certain functions are standard, others are options.

If you do not use the system for 30 minutes, it will switch itself off in order to prevent draining the truck battery. This feature can be cancelled.

Contact your HIAB service workshop.

4.2 How the safety system works

The safety system works as follows:

On the crane there are various sensors and indicators which send signals about the crane's load, position and movements to a central microprocessor. The microprocessor then decides how the crane can be operated and stops/reduces prohibited movements/speeds according to the following:

-
- When prohibited movements/speeds are approached, a warning is given.
 - When prohibited movements/speeds are reached:

On remote controlled cranes prohibited movements are stopped.

On manually operated cranes, all movements are stopped, because when a spool is moved too much, power to the dump valve is cut, all movements are stopped.

Fault monitoring

When there is a fault in the safety system it will give an immediate warning.

Depending upon the fault the crane speed and/or the load capacity will be reduced. When the fault is serious, use of the crane is blocked completely.



DANGER

Never try to repair the safety system yourself.
Repairs may only be made by a HIAB service workshop!

4.3 Components of SPACE 5000 Safety System

Control valve ①

- The crane can be operated from the main control valve, but as soon as you have selected remote control operation, it is impossible to operate the main control valve levers.

User interface - Microprocessor ②

- This is the user interface for SPACE 5000. On this user panel the operator turns on and off the system and activating stabiliser legs and OLP release. Activating the remote control and the signal horn. There is also a stop button on the user panel.

Filter ③

- Pressure reduction filter. The filter feeds the positioners with filtered oil.

Dump valve 1 ④

- To prevent high pressure and thereby unnecessary heating of the oil there is an automatic dumping function. When no lever movement has been made for 3 seconds SPACE system opens the dump valve and the oil is returned directly to the hydraulic tank. As soon as the operator moves a lever the valve closes.

Dump valve 2

- Allows operation of the stabiliser extensions and legs only when this valve is activated. The dump valve 2 will be placed between the main control valve and the stabiliser control valve. The dump valve 2 must be activated from the SPACE interface before the stabiliser system can be controlled.

Decoder ⑤

Remote controller CombiDrive2 ⑥

- The controller is the device that the operator use to control the crane. There is also a stop button on the controller.

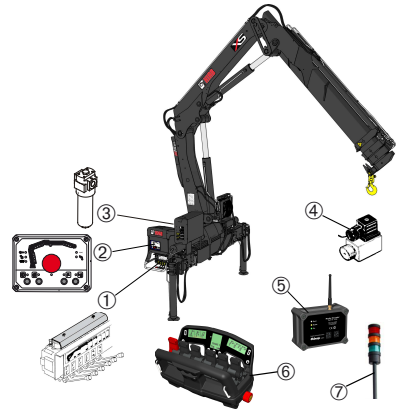

Lamp pole ⑦ [option]

The lamp pole is equipped with 3 lamps. Flashing/light up: green, amber and red.

- green: start up remote control
- amber: prewarning OLP
- amber and red: OLP

4.4 Operating components

- main control valve V91
- stabiliser control valve
- user panel: SPACE 5000
- remote control: CombiDrive2
 - with radio
 - with cable connected

4.5 Main control valve

The speed of a function corresponds to the extent of the lever movement, regardless of the load and other functions, as long as the oil flow is sufficient. When the oil flow is insufficient, one or more functions might reduce their speed.

When remote control is used, the oil flow is allocated by means of PFD.

Main control valve lever function

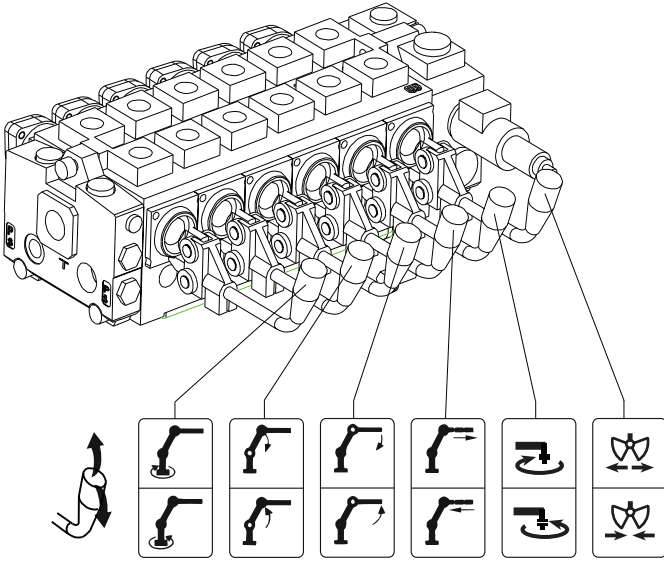

Remote control lever function

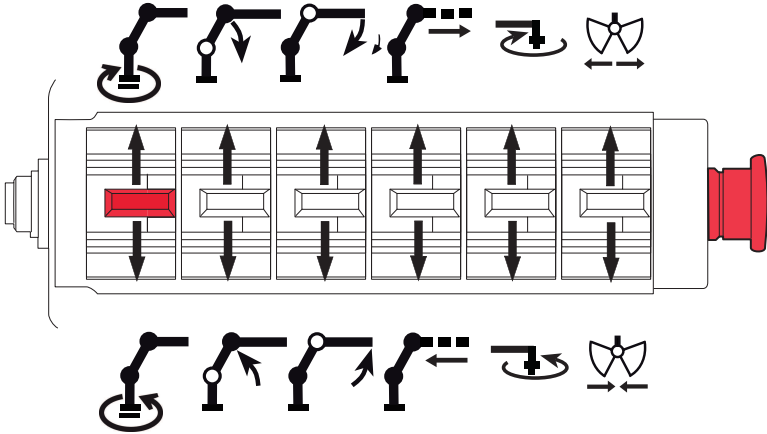

4.6 Stabiliser control valve

The stabiliser control valve is equipped with 2, 3 or 4 levers on each side of the crane.

The levers have the functions:

- **Stabiliser leg ①**
upward/downward
- **Stabiliser extension ②**
out/in

The stop button affects the oil supply to this valve.

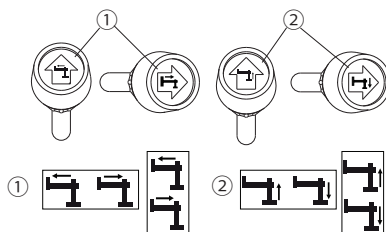

4.7 Extra stabiliser control valve [option]

The stabiliser control valve is equipped with 4 levers.

The levers have the functions:

- **Extra stabiliser extension ①**
out/in
- **Extra stabiliser leg ②**
upward/downward
- **stabiliser extension ③**
out/in
- **stabiliser leg ④**
upward/downward

The 4 levers of one side operate the stabiliser extensions and legs of that side.

The stop button affects the oil supply to this valve.

The stabiliser control valve can be operated manually or remote.

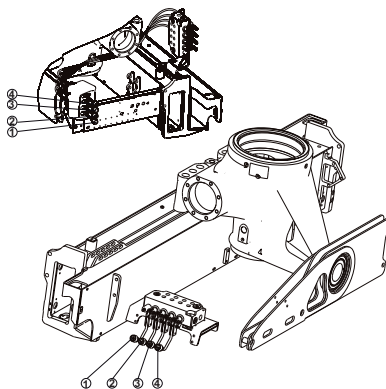

4.8 Cranes with high seat [option]

Cranes fitted with high seat are equipped with a holder for the controller.

4.9 OPS Operator Protection System [option]

- OPS is a system that protects the operator from the boom system's movements when operating the crane.

The OPS system is integrated in the SPACE system, and it uses a sensor on the rack and tilt indicators on the boom system, to indicate the position of the crane.





It creates a virtual cage around the area where the crane operator stands, while manually operating the crane.



4.10 User panel SPACE 5000

Cranes with remote control, type CombiDrive2 and control valve type V91 are equipped with user panel SPACE 5000:

Functions:



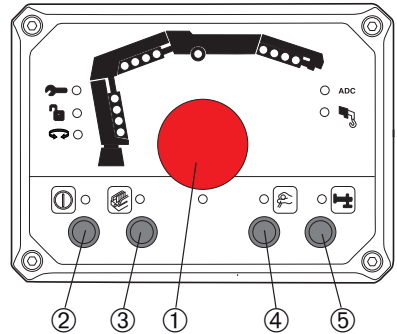

- Stop button ①
When you push the stop button, all crane movements are stopped immediately.
- ON/OFF button ② with the symbol  to switch the safety system On/Off.
- Button ③ with the symbol 
To switch on the remote control and radio control.
- Button ④ with the symbol 
To select manual function.
- Confirm view button ⑤ with the symbol 
To confirm full view of operating the stabiliser extensions outward.

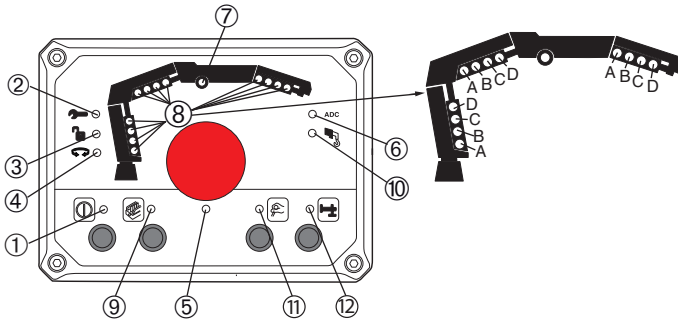

4.10.1 Indicator lights on user panel
SPACE 5000



⑩	Power On	①	<ul style="list-style-type: none"> ● Green light on: The system is on ● Green light flashing: A stop button is depressed.
🔑	Service	②	<ul style="list-style-type: none"> ● Green light on: Time to service the crane. ● Red light on: A non-critical error detected in the system. ● Red light flashing: Critical error is stopping the crane. Diagnostic required. ● Red double flash: CAN error, crane stops.
🔒	OLP Release	③	<ul style="list-style-type: none"> ● Red light on: OLP ● Red light blinking: OLP release button has been pressed. 5 sec to release OLP.
🌀	Slewing sector	④	<ul style="list-style-type: none"> ○ Light off: Inside slewing sector, reduced capacity. ● Red light on: OLP. Vehicle has reached a stability limit. (Also all the 1st boom diodes will light red).
		⑤	<ul style="list-style-type: none"> ● Green light on: Dump valve 1 activated.
ADC	Automatic duty control	⑥	<ul style="list-style-type: none"> ● Green light on: Increased capacity (ADC mode)
	Hoist LED	⑦	<ul style="list-style-type: none"> ● Green light on: Hoist mode. ● Red light flashing: 90% of OLP pressure ● Red light on: 100% of OLP pressure

	Cylinder pressure LED's	⑧	<ul style="list-style-type: none"> ● Green light A on: 50% of OLP pressure ● Green light A-B on: 70% of OLP pressure ● Red light A-C flashes: 90% of OLP pressure ● Red light A-D on: 100% of OLP pressure. ● Red light blinking from A-D: OLP release.
	Remote control	⑨	<ul style="list-style-type: none"> ● Green light on: Remote control. Good radio connection. ● Green light blinking: Stop button pressed/no radio connection. ● Red light blinking: Radio interference.
	Manual extensions	⑩	<ul style="list-style-type: none"> ● Green light on: Manual extension selected. ● Green light blinking: Manual extension selected and 1st manual extension out, but 1st crane extension not out.
	Manual control	⑪	<ul style="list-style-type: none"> ● Green light on: Manual control.
	Stabiliser system	⑪ ⑫	<ul style="list-style-type: none"> ● Green light on: The stabiliser system is ready to use.

4.11 CombiDrive2

Normally the controller operates wirelessly via radio but it can also be operated via cable

Via radio:

The controller contains a radio for two-way communication. This means that information can be sent both from and to the controller. In the decoder/radio there is a corresponding unit which handles the traffic at the other end. The radio is of the “Bluetooth” type and therefore operates in the 2.4 GHz band. This is a free band which has been approved practically world wide. No licence is needed and the radio can in principle be used everywhere, including across national boundaries.

The controller is equipped with a menu selection system as standard. The display continuously provides the operator with information.

The centre display provides information about which menu has been chosen, as well as indicating the radio reception conditions, battery status, fault information, micro, ADC, manual extension, and so on.

The side displays show the symbol for the function which each lever activates in the chosen menu. When the operator changes menu, the symbols change to the functions that become active.

Via cable:

A four-metre cable is supplied as standard with the radio kit of the controller. The cable is intended to be used for short-term operation and when pairing in conjunction with the replacement of controllers or decoders. The cable connects to the vehicle at the left-hand CAN bus connector on the decoder.

If the controller is to be wired permanently or for a long period, an adapter cable is connected from the user panel and installed at a suitable location on the vehicle. To give the operator greater freedom of movement, a 15-metre cable is used between the adapter and the controller.

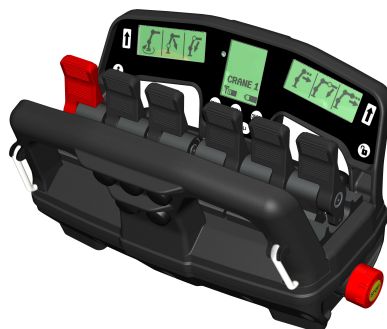

When the cable is connected to the controller, the centre display indicates that the controller is in cable operation mode. The symbols for signal strength (radio) and battery capacity are replaced with the symbol for cable operation.

Low ambient temperature

The LCD-type displays on the controller are somewhat slow in changing state under low temperature conditions. At 0°C, it will take approximately 1 s, and at -20°C it can take up to 8 s before the symbols are completely changed.

Alternating symbols will not be updated at temperatures below freezing.

In order to prevent accidental menu shifts in cold weather, below -10°C, there will be a time delay before any menu button will react to a second depression. In order to avoid this inconvenience, HIAB recommends that whenever the controller is not in use, it should be stored in a compartment where the temperature exceeds +10°C.

Centre display

The centre display provides information about which menu has been chosen, as well as indicating the radio reception conditions, battery status, fault information, micro, ADC, manual extension, and so on. The image to the right shows the centre display as it appears when the controller is started.

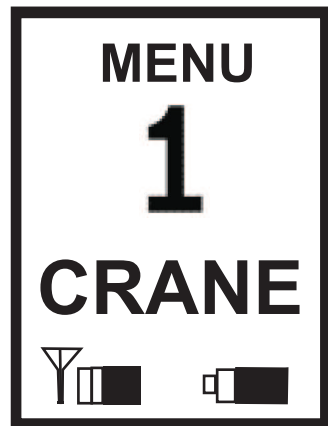
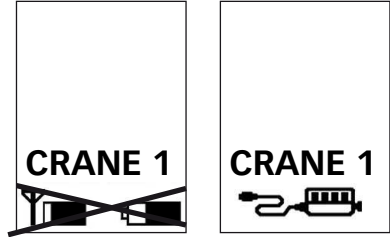

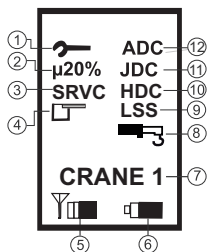

<p>① Error The centre display as it appears when the controller is started.</p>	<p>⑦ Main menu This text shows which main menu that has been selected. The number shows the relevant sub-menu of that main menu. The main menus are CRANE, EXTRA and ON-OFF.</p>
<p>② Micro This text shows which main menu that has been selected. The number shows the relevant sub-menu of that main menu. The main menus are CRANE, EXTRA and ON-OFF.</p>	<p>⑧ Manual extension This text shows which main menu that has been selected. The number shows the relevant sub-menu of that main menu. The main menus are CRANE, EXTRA and ON-OFF.</p>
<p>③ SRVC Indicates time for service. When hand controller is first engaged, the symbol will be shown enlarged for three seconds and then return to normal size.</p>	<p>⑨ LSS (Load Stabilizing System) [option] Indicates that the LSS-V function is active.</p>
<p>④ MEWP (Mobile Elevating Work Platform) Indicates that MEWP (if present) is active.</p>	<p>⑩ HDC Indicates that the HDC function is active.</p>
<p>⑤ Signal strength The bars show the radio signal strength. Five bars indicate optimum reception conditions. If the symbol flashes, the radio is connected but the starting conditions are not met.</p>	<p>⑪ JDC Indicates that the JDC function is active.</p>
<p>⑥ Battery capacity The battery symbol shows remaining energy in the battery. When the symbol begins to flash there is capacity for just a few more minutes. When this happens the horn on the crane will beep twice as an indication of low battery. This information is intended for the Control System, which could give an acoustic signal to emphasize the warning and make the operator aware.</p>	<p>⑫ ADC (Automatic Duty Control) Indicates that the ADC function is active.</p>

Micro / SRVC / MEWP / Manual extension / LSS / HDC / JDC / ADC

When one of the above functions is activated or engaged, the symbol is enlarged for three seconds. It then returns to its normal size. This is to show the operator that a change has happened.

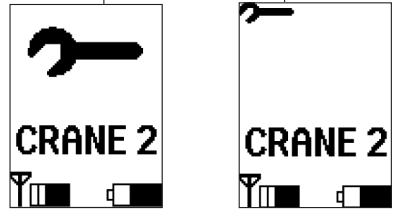
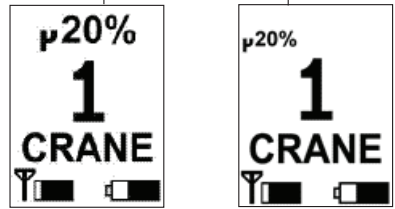

Error indication

This symbol, a spanner, appears if the Safety System has discovered a fault in the system.

Non critical error

Symbol appears enlarged in the center of the display. After three seconds it returns to normal size and moves to the upper part of the display.

Critical error

Symbol remains enlarged in the center of the display. The crane stops.

Error code display

The control system, has the possibility to send error codes to the controller. By pressing button ①, on the left-hand side below the display handle. The centre display changes state to show the error codes.

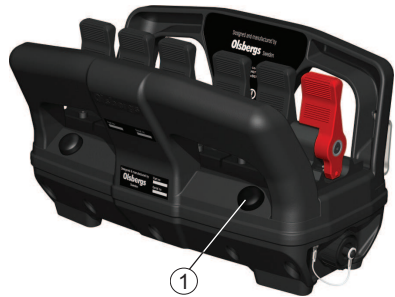

If there are more than six error codes at the same time, the six most recent ones sent from the control system, are shown.

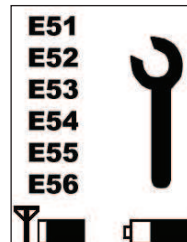

4.12 Main menus CombiDrive2

There are two versions of CombiDrive2, with six or eight levers. Lever 1 to 6 (or 8) (display symbol shows direction of operation with lever forward). The functions of each menu may be the same or different in different menus.

There are three main menus which the operator can toggle between with three pushbuttons:

- Button ① CRANE menu
- Button ② EXTRA menu
- button ③ ON-OFF menu

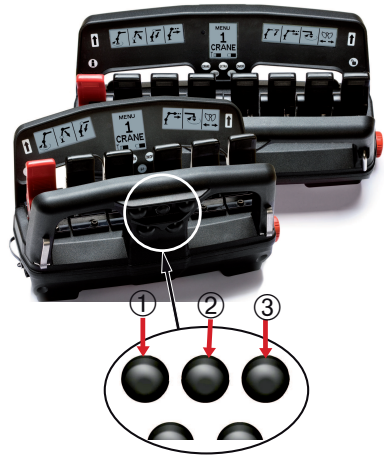

In each of the main menus the operator can step through submenus by pressing the same button repeatedly, e.g. 1-2-3 and then back to 1 again.

The restriction is that one function is only present on a specific lever. If a lever is faulty, or deflected at startup, the lever is disabled. The other levers operate in the usual way.

With the 2 extra levers on the 8 lever controller, it is possible to use the seventh and eighth functions simultaneously with functions 1-6, without shifting CRANE menu.



Menu: CRANE

Button ① CRANE menu

When the operator pulls out the stop button on the controller, it always starts in CRANE 1 menu.

The submenus in CRANE menu are configured in production but can be changed by HIAB service personnel. For every lever there is a corresponding function which it controls. This appears in the left or right display. When the menu changes, by pressing the button ① for CRANE menu, the symbols change and the functions are activated in the current menu. The symbols are stored in a symbol library and can be configured/set via the terminal program for a CE crane.



Symbols for the 8 lever controller:

"CRANE MENU" ③ ↑ ② ↑ ①	Left side display				Centre display	Right side display			
						CRANE 2 			
					CRANE 1 				

Symbols for the 6 lever controller:

	Left side display			Centre display	Right side display			
	<p>"CRANE MENU"</p>				CRANE 3 			
				CRANE 2 				
					CRANE 1 			

Menu: EXTRA**Button  EXTRA menu**

This button activates the EXTRA menu.

The EXTRA menu contains hydraulically proportional functions for example front and rear stabiliser extensions and legs, boat supports, bunk shifting, etc.

These display symbols must match the function being used. The function is logically positioned in relation to the lever.

The symbols are configured in the same way as for the CRANE menu. The same method is used for stepping between the sub-menus.

Left is defined as the side of the crane where the main control valve is normally placed.

The order of the levers is customized.

For the 6 lever controller:

If the crane has 1 stabiliser control valve, the order of the levers should be:

Lever	Functions, lever forward, on the controller
2	Left stabiliser extension out
3	Left stabiliser leg down
4	Right stabiliser extension out
5	Right stabiliser leg down

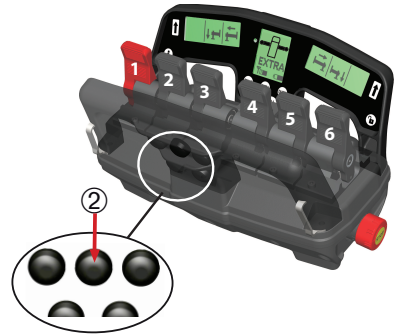

If the crane has 2 stabiliser control valves, the order of the levers should be:

Menu 2:

Lever	Functions, lever forward, on the controller
2	Left crane stabiliser extension out
3	Left crane stabiliser leg down
4	Left auxiliary stabiliser extension out
5	Left auxiliary stabiliser leg down

Menu 3:

Lever	Functions, lever forward, on the controller
2	Right crane stabiliser extension out
3	Right crane stabiliser leg down
4	Right auxiliary stabiliser extension out
5	Right auxiliary stabiliser leg down

For the 8 lever controller:

If the crane has 1 stabiliser control valve, the order of the levers should be:

Lever	Functions, lever forward, on the controller
3	Left stabiliser extension out
4	Left stabiliser leg down
5	Right stabiliser extension out
6	Right stabiliser leg down



If the crane has 2 stabiliser control valves, the order of the levers should be:

Lever	Functions, lever forward, on the controller
1	Left auxiliary stabiliser extension down
2	Left auxiliary stabiliser leg out
3	Left crane stabiliser extension down
4	Left crane stabiliser leg out
5	Right crane stabiliser extension out
6	Right crane stabiliser leg down
7	Right auxiliary stabiliser extension out
8	Right auxiliary stabiliser leg down

Menu: ON-OFF

Button ③ ON-OFF menu

This button enables the on-off functions.

The ON-OFF menu includes functions such as start, stop and throttle. The functions are configured by the bodybuilder.

Currently there are no symbols for these functions. Instead, text can be entered directly into the window that corresponds to each function.

Only ordinary numerals and the letters of the English alphabet can be used. For each sub-menu, four functions may be defined. The functions are controlled by levers 2 – 5.

A lever may be deflected in any direction in order to activate the corresponding function.

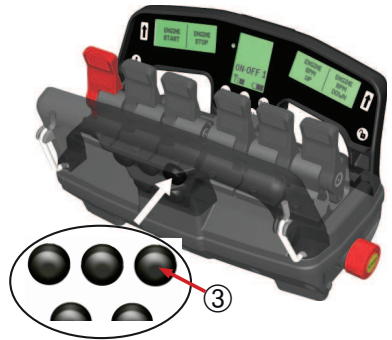

"ON-OFF MENU"	Left side display		Centre display	Right side display	
		FRONT LIGHT	REAR LIGHT	ON-OFF 2 	PUMP 1
	ENGINE START	ENGINE STOP	ON-OFF 1 	ENGINE RPM UP	ENGINE RPM DOWN

4.13 Battery charger CD2

The battery charger is to be fitted in a protected environment, preferably in the cab. Two batteries are delivered with each unit, one of which can always be placed in the charger.

Display A

- ① lights when the charger is activated.
- ① and ② lights during charging.
- ① and ③ lights when the battery is fully charged.

Display B

Shows the battery voltage (8.4).

When the display blinks 0.0 there is error in the battery: Change battery.

Charging time

The normal charging time for a flat battery, is approximately 3 hours. The battery charger is designed not to damage the battery, even during long continuous charging.

Operating ambient temp:

Battery = 0° to + 45°C.

A charged battery

The voltage level of a fully charged battery is approximately 8,4V and it provides about 5-8 hours working time. Note that the battery voltage remains between 7,6V and 7,5V for a long time. Therefore, the battery voltage cannot be used to estimate the working time.



! NOTE

A charged battery is a concentrated energy source. Never store a charged battery in a toolbox or similar, where there is a risk of a short due to metal components.

Used batteries should be taken care of according to the local regulations.

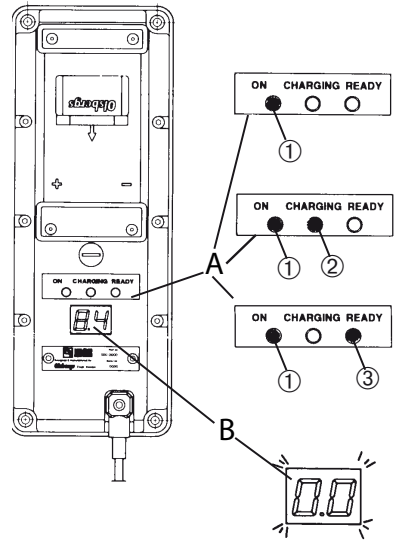

Installing the battery

Install a fully-charged battery in the controller as shown on the right.

It is important to fit the battery the right way round. If the battery is upside-down the controller will not start.

A fully charged 1200 mAh battery will power the controller for approximately 5 hours.



4.14 Functions

Locking / unlocking the controller

The controller can be locked to prevent unauthorised persons from starting the controller and operating the crane.

Locking the controller

1. Press and hold button ② and ③ while the stop button is pressed.
2. Keep button ② and ③ pressed while pulling out the stop button. The centre display then shows a large locked padlock symbol .



Unlocking the controller

1. Press and hold button ② and ③ while the stop button is pressed.
2. Keep button ② and ③ pressed while pulling out the stop button.
3. Release button ② and ③.

The controller is ready to use.

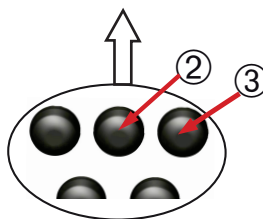

APO Automatic power off

APO is a function which automatically switches off the power for the SPACE system. It consists of:

1. Timeout controlled power off. (30 minutes by default).
2. Parking brake controlled power off.

Through the vehicle's parking brake, APO offers a safety function which ensures that the SPACE system is off when the vehicle is moving. When parking brake is released, SPACE receives a signal and shuts OFF the system.

For emergency operation

During 5 seconds, it is possible to activate the SPACE system by pressing the ON/OFF button on the user interface.

ADO Automatic dump function

If a lever is not moved for 3 seconds, this function diverts the oil to the tank, thereby preventing the oil from overheating. The next lever movement stops the dumping and it functions as normal.

Disconnecting the automatic dump function (ADO)

In certain cases the automatic dump function must be disconnected. The most common case is before operating a separate stabiliser control valve (which is not equipped with spool sensors)

To disconnect the automatic dump function:

1. Press the Button ①.
The LED ② is lit constantly when automatic dump function is disconnected.
2. Press the Button ① again.
The automatic dump function is now connected again.

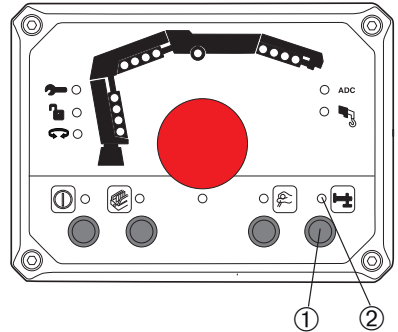

When the power is switched on, the automatic dump function is always connected.

ASC Automatic Speed Control

The ASC function automatically provides the extra power by reducing the speed smoothly, when working close to the rated capacity. When the load decreases, normal speed is restored.

ADC Automatic Duty Control

The purpose of the ADC function is to increase the lifting capacity by 10%.

The first boom pressure sensors indicate if there is a positive or negative pressure on the first boom.

Normal capacity

- If the first boom is pressed down, the sensors indicate a negative pressure and the lifting capacity is normal during the complete lifting cycle.

Increased capacity (ADC mode)

- ADC lamps light up.
If the sensors indicate a positive pressure, the lifting capacity is increased during the complete lifting cycle.

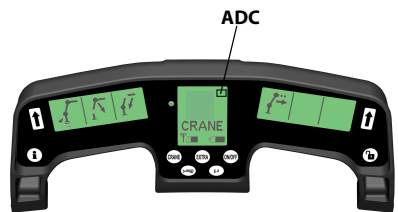
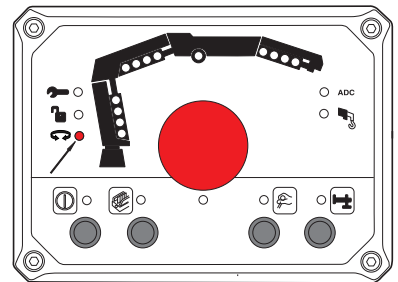

PFD Pump flow distribution

When operating several functions simultaneously the pump flow may not be sufficient. PFD will now take over, reducing the speed of all operated functions. Uncontrolled movements are thus avoided, smooth simultaneous operation is achieved.

Controlling crane speed

Use the button ① to change resolution of the lever to 50% or 20% of normal speed.

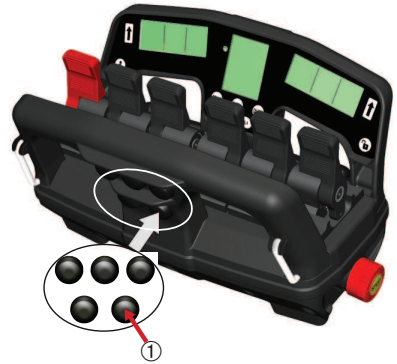
**Slewing sector [option]**

Within slewing sector, lifting capacity can be reduced due to stability. The overload warning will be given at a lower load in the limited sector than outside the sector. In case of an overload warning you may slew out of the sector but not further into it.

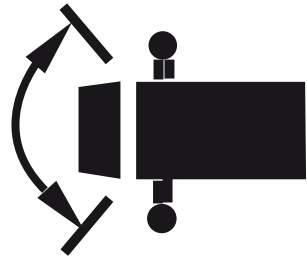

5.1 Starting operations

Placing the vehicle

- **General case:**

Place the vehicle on a flat and firm surface. The vehicle inclination (α) during crane operation must **not be more than allowed in the Technical Data for your crane.**

To determine the inclination of the truck, check the spirit level on the crane. When the bubble is in the middle of the gauge, the crane is in horizontal position. When the bubble is between the two circles, the crane inclination is between 0° and 5° .

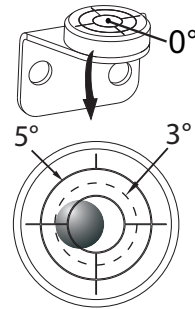

If the slope exceeds the permitted inclination, unintentional crane movements can occur.

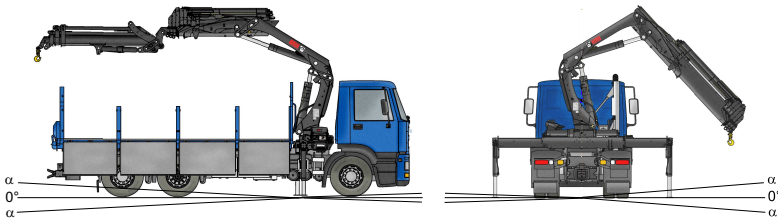

- **Particular case: Working with boom system beyond 60°**

To avoid side deflection and in order to guarantee the safest operation when working with e.g. hoist and/or JIB/MEWP applications, the vehicle has to be completely levelled in any direction.



! NOTE

- Operating the crane in to and out of parking position must also be done with the vehicle completely levelled.
- Activate the parking brake and place chocks under the wheels to prevent vehicle movement.

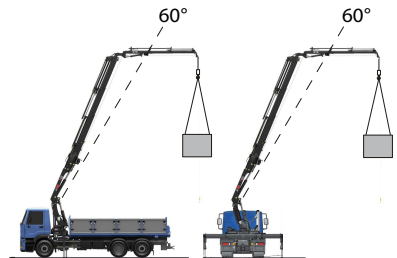

Engage the PTO

- Engage the PTO (Power Take Off).
- Bring the vehicle's engine to the correct rpm.



! NOTE

- Rpm too high: the oil in the hydraulic system might overheat. Rpm too low: during crane operation, the vehicle's engine could stall.
- The maximum rpm may depend upon a governor on your PTO combination.

CD2 Start the safety system

The operating levers must be in neutral position before start up.

To activate the system, press the On/Off button on the user panel. The LED above the button starts to blink.

The system will check itself (2-4 seconds).



Remote control CD2

1. Fasten the controller to a waist belt, or shoulder-/neck strap, in the most comfortable operation position. The Stop button should be on the right hand side.
2. Press the remote control button on the user panel. The diode above that button gives a steady light. The green lamp on the lamp pole [option] lights.



3. To activate the controller, pull out the stop button by turning it clockwise. The radio starts to establish a link with the decoder. "Wait" is displayed while radio contact is being established.



Decoder LED's colour:

- ① green
- ② yellow
- ③ red

The decoder is powered on when remote control is chosen. LED ① is lit. The LED ② on the decoder starts to blink.

Radio link established

- When the radio link has been established, LED ② on the decoder gives a steady light and LED ① flickers.
- On the controller, CRANE 1 menu and signal strength are displayed.

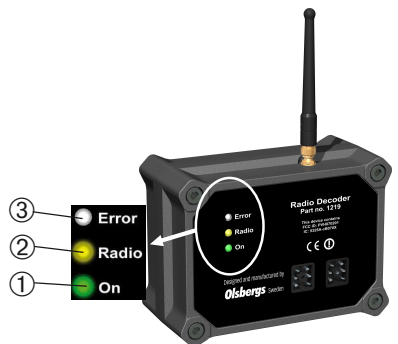

Cold starting CD2

The connection time for cold starting may be as much as five seconds. Cold starting means that the controller has been in stand by mode for the last ten minutes. If you restart the controller within ten minutes, the radio link is still established and the controller is ready for immediate use. (Ten minutes is default value but can be set to a value between one and thirty minutes.)

The controller will always start in CRANE 1 menu, regardless of which menu was active when the controller was stopped.

CD2-Operating the stabiliser system



WARNING

All levers must be in neutral position.



DANGER

When you are operating the stabiliser extensions: Make sure that you have full view of the stabiliser extensions. Do not stand in front of hydraulically operated stabiliser extensions.

From remote controller:

- Turn the stop button on the controller.
- Press the remote control button 
- Press the button EXTRA menu on the controller to select programmed menu for stabiliser extensions and legs.



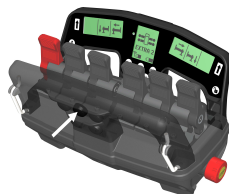
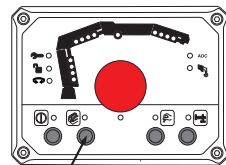
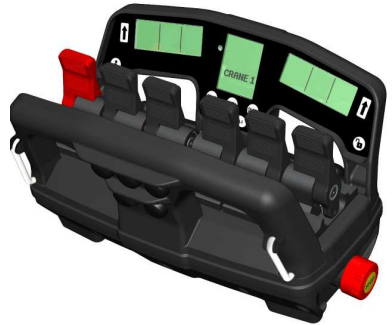

! NOTE

The stabiliser legs can be driven up and down regardless of the side.



Manual controlled stabiliser extensions and legs:

- Press the button  and the button  to operate the stabiliser extensions and legs manually.

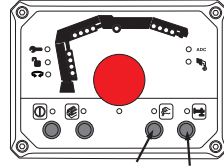

If separate stabiliser leg valve:

Press the button  to disconnect the automatic dump function and operate the stabiliser extensions and legs from the stabiliser leg valve.

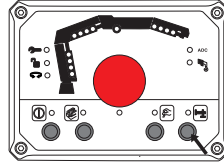

5.2 Extend stabiliser extensions and set stabiliser legs

To ensure the full stability, all the stabiliser extensions and legs must be fully extended and set to the ground without lifting the wheels off the ground.



WARNING

Take care not to lower the stabiliser leg to your foot.



DANGER

Check that the support plates do not bend or sink into the ground!



WARNING

Always ensure that the stabiliser legs and stabiliser extensions are in working position and securely locked.

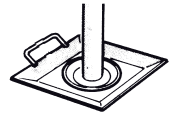
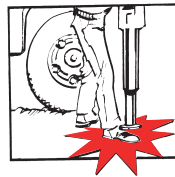
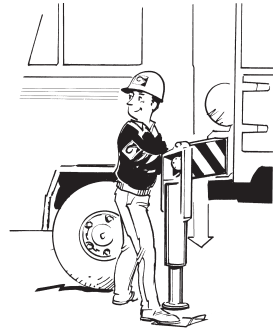

Place the extra support plates [option]

- Place the extra support plates under the stabiliser leg plates to ensure that the maximum ground pressure is less than 4MPa.

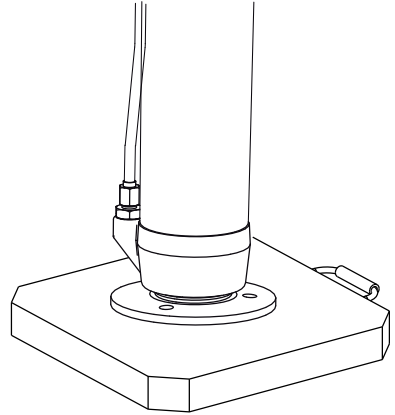
**Operation with non-tiltable stabiliser legs:**

1. Unlock the catcher ①.
2. Extend the stabiliser extension.
3. Set the stabiliser leg to the ground.

Repeat for the stabiliser extension and leg on the other side of the vehicle

When there is an additional set of stabiliser legs [option]: Repeat the process for the 3rd and 4th stabiliser legs.

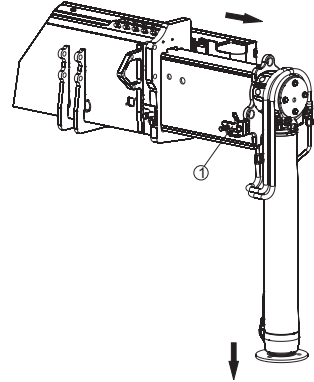

Operation with manual tiltable stabiliser legs:

1. Unlock the catcher ①.
2. Unlock the stabiliser leg lock ②, that holds the stabiliser leg in the transport position.

DANGER:

Do not stand in the stabiliser leg tilting area.

3. Tilt the stabiliser leg downward.
4. Lock the stabiliser leg lock ②.
5. Extend the stabiliser leg extension.
6. Set the stabiliser leg to the ground.

Repeat for the stabiliser extension and leg on the other side of the vehicle

When there is an additional set of stabiliser legs [option]: Repeat the process for the 3rd and 4th stabiliser legs.

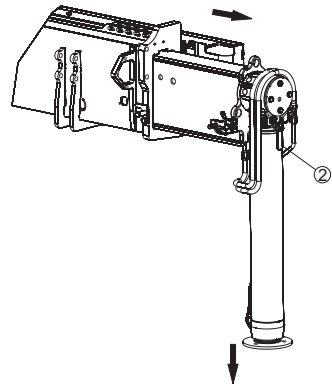
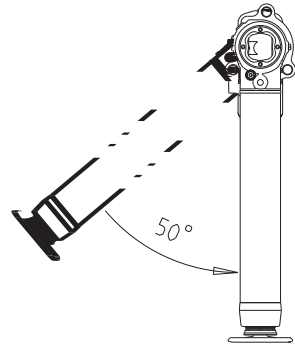
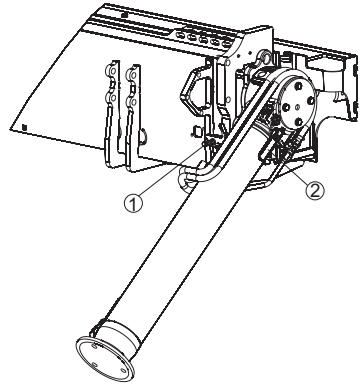

Manually tilting stabiliser legs with gas spring support

1. Extend the stabiliser extension until the stabiliser leg can rotate freely of the vehicle (for manually operated stabiliser extensions, unlock the catcher ① and the handle ②).
2. Place your right hand on the handle ③ while unlocking the stabiliser leg ④ with your left hand. Make sure the leg drops in a controlled movement until it stops.
3. Push the handle until the leg points down.
4. Lock the stabiliser leg.

Repeat for the stabiliser extension and leg on the other side of the vehicle

When there is an additional set of stabiliser legs [option]: Repeat the process for the 3rd and 4th stabiliser legs.

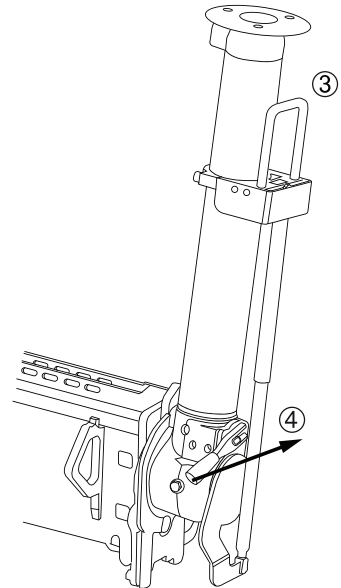
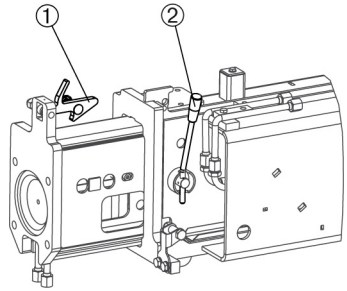

Operation with tiltable stabiliser legs:

1. Unlock the catcher ①.
2. Extend the stabiliser extension a little, until the stabiliser leg can be rotated free of the vehicle.
3. Tilting the stabiliser leg:



WARNING

To minimise the risk for the stabiliser leg to tilt down by itself, retract the stabiliser leg.

Unlock the stabiliser leg lock ②.



DANGER

Do not stand in the tilting area. Make sure the tilting mechanism remains unlocked during the complete tilting.

Operate the lever to extend the stabiliser leg. This will also tilt the leg to vertical position.

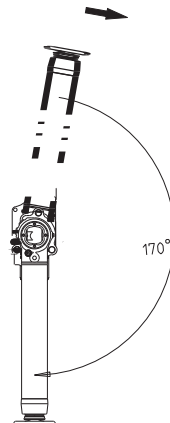
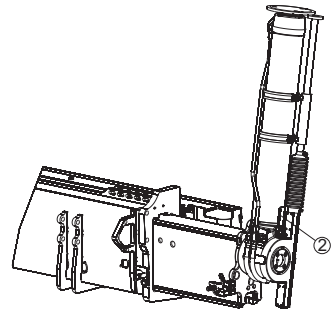
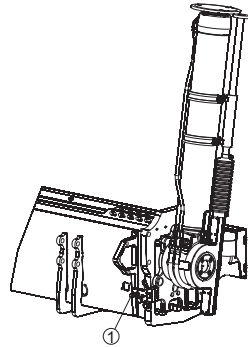

4. Lock the stabiliser leg lock ②.
5. Extend the stabiliser extension.
6. Set the stabiliser leg to the ground.

**WARNING**

Always check that the stabiliser legs and the stabiliser extensions are in correct position and tilting mechanism is locked in working position.

Repeat for the stabiliser extension and leg on the other side of the vehicle

When there is an additional set of stabiliser legs [option]: Repeat the process for the 3rd and 4th stabiliser legs.

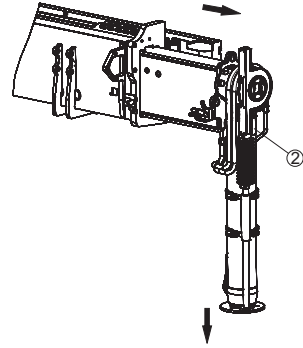

5.3 Operate the crane out of parked position



WARNING

- A crane with add-on equipment can differ from the operations described in this section.
- For this reason study the operating instructions for add-on equipment carefully.

Once the stabiliser extensions and legs are ready you can start using the crane:

1. If stabiliser system is under manual control, push button  on the user panel.
2. If using remote control, push button ① on the controller to change the menu into crane operation.



DANGER

Always operate manually controlled crane from the position indicated !

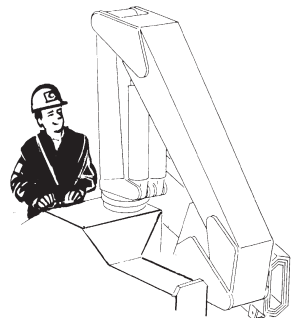

Operate the boom system

1. Turn the pin ① and pull it out
2. Raise the first boom ②.
3. Place the second boom in vertical position as shown in the figure, to be able to free the extension from the catcher ③.
4. Extend the first extension until it comes free of the catcher ③.
5. Raise the boom system.
6. Slew the crane to the working position. The crane is now ready for use.

**! NOTE**

As soon as you have selected remote control operation, it is impossible to operate the main control valve levers.

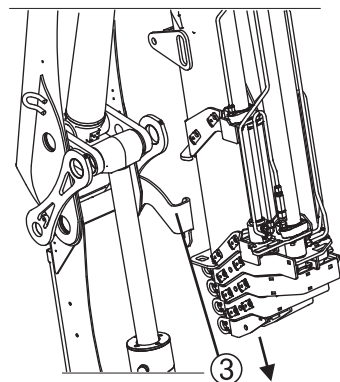
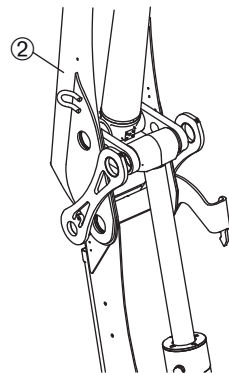
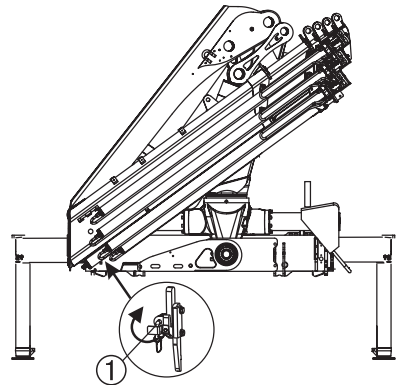

6.1 OLP (Overload protection)

OLP HiPro Crane

The OLP function is a safety function in SPACE that prevents overloading of the crane.

With 90% of maximum permitted load, a pre-warning is given. The yellow lamp on the lamp pole [option] flashes and the cylinder pressure LED's flash red.

When 100% of the maximum permitted pressure is reached, the OLP cuts in. The display shows whether a particular motion is prohibited or if the crane is subject to OLP. The red and the amber lamps on the lamp pole [option] will light all the time and the cylinder pressure LED's will light continuously.



OLP Boom system**Warning at 50%, 70%, 90% and 100% visible on the controller**

- The pressure in the cylinders is displayed as a percentage of the maximum permitted pressure.
- The percentage pressure loading in the cylinder is displayed in the window of the respective lever as a number: 50%, 70%, 90% and 100%.
- When the pressure is 50% or more, the percentage alternates with the lever symbol once a second.
- When a pressure sensor reaches 100 %, all motions that would increase torque are blocked.
- If the operator attempts to activate a blocked function, the function symbol is replaced by a cross while the lever is deflected. When the lever is returned to the neutral position, the cross disappears and the information returns.
- Operate permitted (load reducing) functions only.

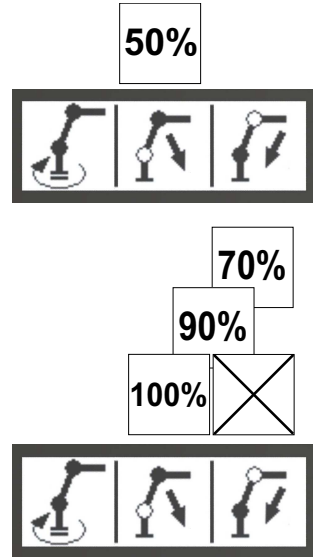
**! NOTE**

Do not operate heavy loads with the extensions fully retracted. In an OLP situation it is an advantage to be able to retract the extensions.

Warning at 50%, 70%, 90% and 100% visible on the user panel

- Indicator lamps ① are flashing on the user panel when load is close to rated capacity and light up at rated capacity.

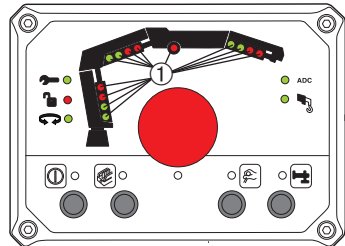

To release OLP (CombiDrive2)

In certain OLP situations, the first and second booms can be locked. It is then possible to release the OLP for approximately 5 seconds, by pressing the button ① on the right hand side below the display handle. There is a waiting time before the release operation can be activated again. The time increase in three steps: 30, 60 and maximum 90 seconds (the time starts to count down as you move the lever).

During this period it is possible to operate an appropriate crane function so as to correct the overload situation. Only one unallowed function at a time can be operated. Extension out cannot be operated.

The unlocked padlock will appear in the centre display.

On the user panel the cylinder pressure LEDs and the LED for padlock symbol will flash red.

Manual control

If one prohibited movement is used, all movements will stop. The crane will be fully operational as long as only allowed movements are used.

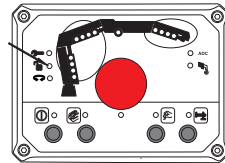
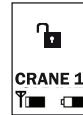

DANGER

Only use the OLP override to get the crane out of a locked position. Never use the OLP override to overload the crane deliberately!

6.2 BDA Boom Deployment Assistance [option]

BDA is a safety function in SPACE that prevents the operator to move the second boom and extensions in the wrong direction when operating the crane in to or out of parking position.

- Operating the crane to parking position:

When the angle β is $>135^\circ$ between the horizontal and second boom, the system doesn't allow to raise the second boom or to move extensions out/in.

Press the button  to allow second boom and extensions movements.

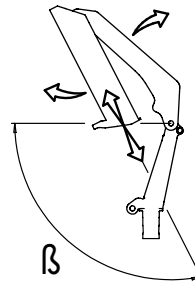
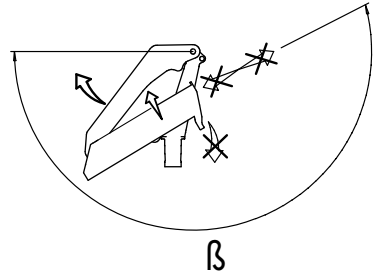

DANGER

Only use the BDA override to get the crane out of a locked position.

- Operating the crane out of parked position:

When the angle β is $<135^\circ$ between the horizontal and second boom, second boom and extensions can move without any restrictions.

6.3 Manual extensions [option]

Operation with manual extensions

- Always extend the hydraulic extensions first, then the manual extensions.
- The use of manual extensions should be restricted to the longest outreach needed. When this reach is not needed, the manual extension should be retracted.



DANGER

Do not stand in front of moving parts. They may eventually move and cause injuries.

To extend the manual extensions

1. Locate the boom system as close as possible to the horizontal position, but low enough to reach the extension by hand.
2. Stop the crane, by pressing the stop button.
3. Remove the locking device ① and the locking pin ②.
4. Extend the manual extension fully by hand.
5. Secure the manual extension, by locking the pin ② and locking device ①.

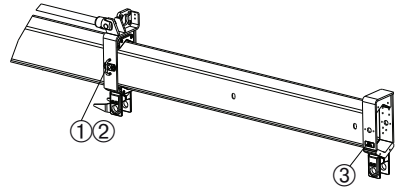

DANGER

- Make sure that the locking device is properly locked.
- Each manual extension has a sign ③ for the maximum load that can be handled.
- Do not lift loads heavier than the values stated on the hook attachment.

To lift heavier loads than specified on the sign ③, the hook position must be moved to the nearest hydraulic extension, in accordance with the load plate on the crane.

To retract the manual extensions

1. Locate the boom system as close as possible to the horizontal position, but low enough to reach the extension by hand.
2. Stop the crane, by pressing the stop button.
3. Remove the locking device ① and the locking pin ②.
4. Retract the manual extension fully by hand.
5. Secure the manual extension, by locking the pin ② and locking device ①.

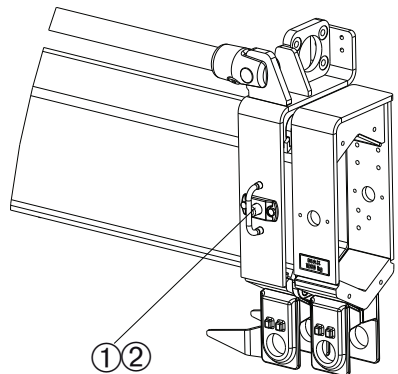

DANGER

- Make sure that the locking device is properly locked.

Activate and de-activate OLP for manual extensions



WARNING

You must switch the OLP on and off manually for additional manual extensions!

Activate:

Push and hold both Release button ① and Horn button ② until symbol  on the centre display is lit.

(The lamp for manual extension is lit on the user panel.)

The manual extensions are now included in the OLP protection. The lifting capacity will be reduced automatically.

De-activate:

Push the button ① and ② again. The symbol  on the centre display goes out.

(The lamp for manual extension goes out on the user panel.)

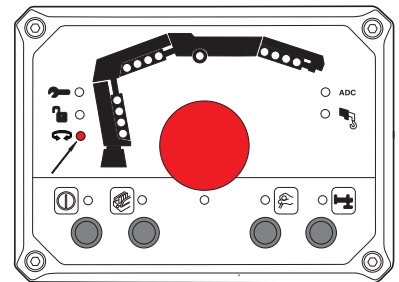
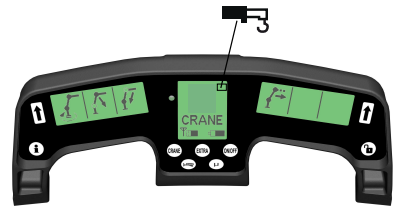
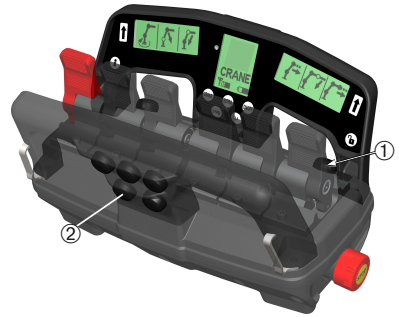

7.1 Operate the crane to parking position



WARNING

- A crane with add-on equipment can differ from the operations described in this section.
- For this reason, study the operating instructions for any add-on equipment carefully before you fold the crane.

Always operate manually controlled crane from the position indicated in the figure.

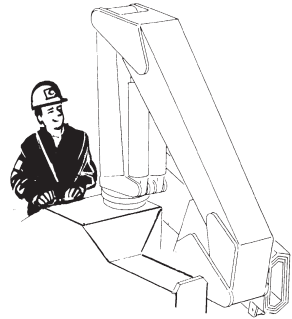

! NOTE

If the crane has OPS, press the button ② and hold it in, while carrying out points 4-5

1. Slew the crane until the crane is square on the vehicle.
2. Retract all extensions.
3. Raise the first boom.
4. Operate the second boom to vertical position as shown in the figure. To be able to lock the extensions, slide out the first extension about 500 mm. **NOTE!** Take care not to damage the catcher ③ during this operation. Retract the first extension slowly and adjust the second boom to ensure that the extension is locked by the catcher ③.
5. Lower the first boom on to the parking support, on the crane base.
6. Lock the boom with the pin ①.
7. Fold in the hook.

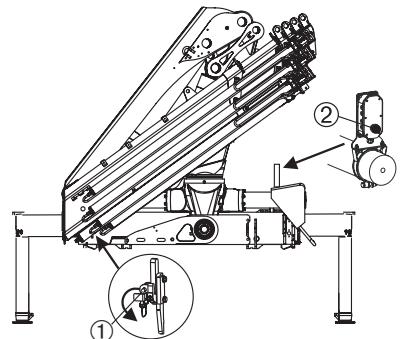
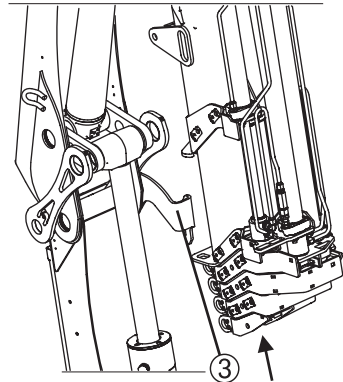

7.2 Placing the stabiliser extensions and legs in transport position

Activate operation of stabiliser extensions and legs.



DANGER

Do not stand in the stabiliser legs, tilting area.



DANGER

Always ensure that the stabiliser legs and the stabiliser extensions are in transport position and securely locked.



WARNING

Do not put your foot on the support plate.



Operation with non-tiltable stabiliser legs:

1. Retract the stabiliser leg.
2. Retract the stabiliser extension completely.

WARNING

Risk of crushing injuries.

Always keep hands away from moving parts during operation.

3. The catcher ① will lock the stabiliser extension.

Repeat for the stabiliser extension and leg on the other side of the vehicle

When there is an additional set of stabiliser legs [option]: Repeat the process for the 3rd and 4th stabiliser legs.

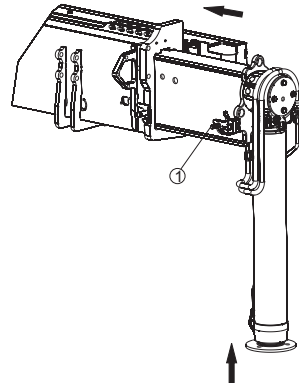

Operation with manual tiltable stabiliser legs:

1. Retract the stabiliser leg completely.
2. Unlock the stabiliser leg lock ①.
3. Tilt the stabiliser leg manually.
4. Lock the stabiliser leg lock ①.
5. Retract the stabiliser extension completely.

WARNING

Risk of crushing injuries.

Always keep hands away from moving parts during operation.

6. The catcher ② will lock the stabiliser extension.

Repeat for the stabiliser extension and leg on the other side of the vehicle

When there is an additional set of stabiliser legs [option]: Repeat the process for the 3rd and 4th stabiliser legs.

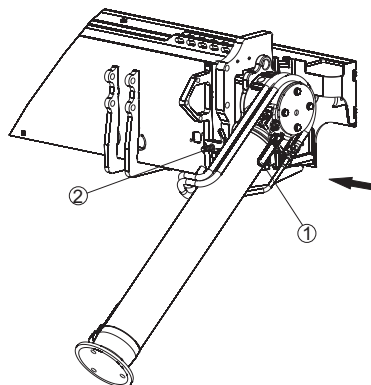
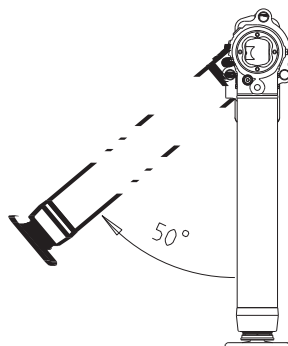
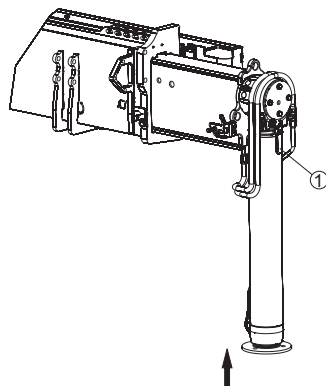

Manually tilting stabiliser legs with gas spring support

1. Raise the stabiliser leg completely.
2. Place your right hand on the handle ③ while unlocking the stabiliser leg ④ with your left hand.
3. Gently pull the stabiliser leg upwards until it stops. Make sure the leg travels in a controlled movement.
4. Push the leg up until it reaches parking position.
5. Lock the stabiliser leg.
6. Retract the stabiliser extension completely. (For manually operated stabiliser extension, unlock the handle ②. Retract the extension and lock it again. Check that the catcher ① is secured.)

WARNING

Risk of crushing injuries.

Always keep hands away from moving parts during operation.

Repeat for the stabiliser extension and leg on the other side of the vehicle

When there is an additional set of stabiliser legs [option]: Repeat the process for the 3rd and 4th stabiliser legs.

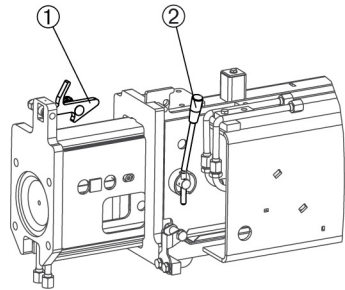
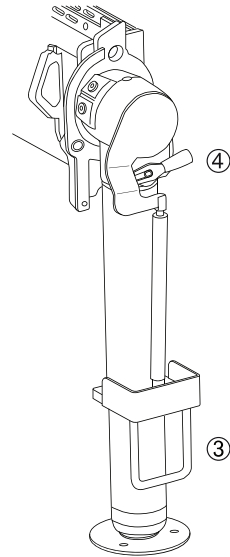

Operation with tiltable stabiliser legs:

1. Retract the stabiliser leg so it is just free of the ground.
2. Unlock the stabiliser leg lock ① and continue to retract the stabiliser leg. When there is approximately 200mm left of the piston rod, the leg will tilt into parking position.

DANGER:

Do not stand in the tilting area. Make sure the stabiliser leg remains unlocked during the complete tilting.

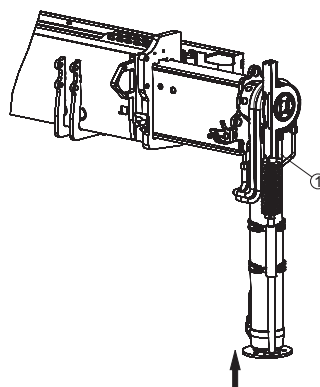

3. Lock the stabiliser leg lock ①.
4. Retract the stabiliser extension completely.

WARNING

Risk of crushing injuries.

Always keep hands away from moving parts during operation.

5. The catcher ② will lock the stabiliser extension.

Repeat for the stabiliser extension and leg on the other side of the vehicle

When there is an additional set of stabiliser legs [option]: Repeat the process for the 3rd and 4th stabiliser legs.

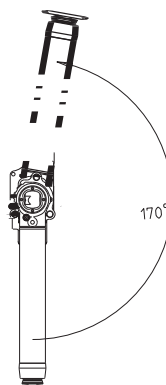
**7.3 Switching off the safety system**

- Push in the stop button and switch off the safety system.
- Disengage the PTO.

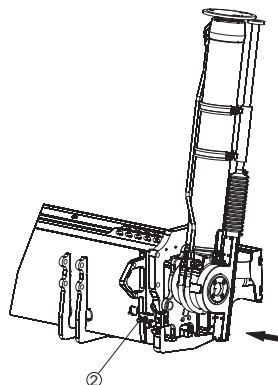

7.4 Emergency operation Valve-V91

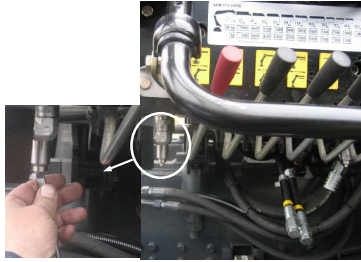

EMERGENCY operation to bring the crane to parking position

Do like this:

On the main control valve:

1. Break the security sealing on dump valve 1 on the inlet section.
2. Press the dump valve button and turn 90 degrees until it is blocked.
3. Operate the crane to parking position using the levers on the main control valve.

Separate stabiliser control valve:

The button on dump valve 1 on the main control valve is to remain depressed.

1. Break the security sealing on dump valve 2.
The dump valve 2 is placed on the main control valve, on the outlet section.
2. Press the dump valve button and turn 90 degrees until it is blocked.
3. Operate the stabiliser extensions and stabiliser legs to parking position using the levers on the stabiliser control valve.

**DANGER**

To operate the crane like this is **HIGHLY DANGEROUS** because during emergency operation all crane security is disconnected.

Always go to/contact a HIAB service workshop when the seal wire has been broken.

7.5 TWI Transport warning interface [option]**WARNING**

If you switch off the safety system when manual operated stabiliser extensions/tiltable stabiliser legs are not locked in the transport position, and/or if the first boom angle exceeds a certain specified angle, the indicator lamps for both the cylinders and the hoist will flash red for a while.

The vehicle must not be moved.



- A warning, visible and audible from the driving position for transport, indicates when the crane height exceeds a predetermined maximum and when the manual operated stabiliser extensions/tiltable stabiliser legs are not locked in the transport position.
- The audible warning can be silenced by an acknowledgement button [option] or by a signal indicating that the parking brake of the vehicle is engaged.

**The vehicle must not be moved**

1. Switch the system on, put the crane into the transport position.
2. Switch off the system. The vehicle may be moved.

**DANGER**

After use always put the crane into the transport position! When you have to park the boom on the load space, or over the load, secure the boom and the lifting accessories to prevent any unintentional movement of the crane and the lifting accessories.

8.1 Service



DANGER

- Do not do any welding work on the crane yourself! Welding work on the crane may only be carried out by, or in close consultation with, a HIAB service workshop.
- Do not drill into the crane yourself. Drilling work on the crane may only be carried out by, or in close consultation with, a HIAB service workshop.
- Never try to reinstall the crane. Only a HIAB Dealer may reinstall the crane.

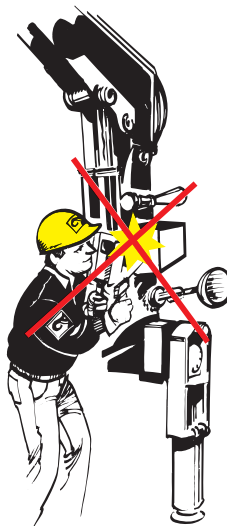

Before carrying out any welding on the vehicle:

- Disconnect the power between the vehicle and the crane.
- Contact the vehicle manufacturer.

After welding on the vehicle:

- Connect the power between the vehicle and the crane.

Leakage

**DANGER**

- Keep well away from an oil leak on the hydraulic system! The oil spraying out can cause serious injury. The oil in the hydraulic system is under high pressure.
- Do not replace any hydraulic hoses or lines yourself: Precautions shall be taken when disconnecting hydraulic lines and hoses to ensure that no hydraulic pressure is retained in the line when the power supply to the system is switched off. Pressure may be retained in the hydraulic lines when the power supply has been switched off.
- Always contact a HIAB service workshop.

Deal with an oil leak as follows:

1. Rest the crane on the floor or on the truck platform.
2. Switch off the operating system.
3. Disengage the PTO.
4. Leaking coupling:
 - Tighten the coupling with a spanner.
 - If tightening does not help: contact a HIAB service workshop.
5. Small leak on a line or hose:
 - Determine if you can still park the crane.
 - If you can: park the crane and go to a HIAB service workshop. If you cannot: contact a HIAB service workshop.
6. In all other cases, contact a HIAB service workshop.

**8.2 Warranty****HIAB only provides a warranty if:**

- The instructions for maintenance and service have been followed, and original HIAB parts have been used.

-
- All security seal wires on the valves are still intact.

Always use original HIAB parts and tools.

8.3 Follow the maintenance instructions!

Take the crane, at least once a year, to a HIAB service workshop for inspection and maintenance. Maintain lifting accessories according to the supplier's instructions.



WARNING

- Ensure that faults in the crane are corrected immediately!
- Never correct faults yourself that may only be corrected by a HIAB service workshop.
- Carry out yourself only the service and maintenance work you have the requisite knowledge and experience of.

If the crane is not be used for 1 month or longer:

- Lubricate the crane thoroughly, according to the lubrication schedule.
- Park the crane in the transport position.

Filters

Replace the filter cartridge

- after the first 50 hours operation
- then after every 500 hours operation
- or at least twice a year.

Cleaning

Clean your crane and accessories regularly, but:

- Do not use aggressive cleaning agents.
- Never use a high pressure jet cleaner on electronic parts, plastic components, signs, bearings, control valves, cylinders or the oil tank. Only the cranes surface may be cleaned with a high-pressure jet cleaner.

8.3.1 Daily inspection

Stabiliser locking devices

- Check that the stabiliser locking devices are undamaged and working properly.

Shafts, shaft lockings, bearings and bushings

- Check that the shafts, shaft lockings, bearings and bushings are undamaged and working properly.

Stop buttons

- Check that the Stop buttons are undamaged and working properly.

Hook, hook lock and hook suspension

- Check that these are in good condition.

Levers

- Check that the levers operate smoothly.
- Check that the levers return to the neutral position.

Electronic components

- Check that these are in good condition.

Crane structure

- Check for damage to the crane structure (e.g. any formation of cracks).



DANGER

In the event of damage that presents a safety risk:

- Do not use the crane.
- Have the damage repaired immediately by a HIAB service workshop.

Hydraulic system

- Check that there are no leaks from the hydraulic hoses, lines and connections.

Filters

- Check the filter indicator. If red replace the cartridge.

LED test

To do the test:

1. Press the ON/OFF button for at least 2 sec.
The test is activated and all the red LED's are illuminated.
If the system is equipped with lamp pole, all three lamps will light.
2. Release the button. After 3 sec, all the green LED's are illuminated. The test is finished when all LED's is extinguished.

Add-on equipment (hoist etc.)

- Check the cables, cable connections, the cable guides and the attachment points for the add-on equipment.
- Maintain all add-on equipment, auxiliary equipment etc. according to the instructions supplied with it.

Oil tank level

- To check the level in the oil tank:
Place the vehicle on level ground with the crane in transport position.
- If necessary, top up.

Slewing housing oil level

- Check the oil level in the slewing housing.
- If necessary, top up.

8.3.2 Monthly inspection and maintenance

In addition to the daily inspection, carry out the following each month:

Piston rods

- In cases where the cylinder piston rod is exposed to pollution due to the parking location, the chromed surfaces must be cleaned and oiled to prevent corrosion. This needs to be done regularly.

Presence of decals

- See chapter Safety precautions and warnings under section Warning signs. Check that all the decals shown in section Warning signs are in position.

Pivot pins and bushes

- Inspect all the pivot pins and bushings for the crane boom and cylinders for damage, play, etc.

Bolts and screw fixings

- Check that bolt and screw fixings are tightened.

Cables and sensors on the boom system

- Check that these are in good condition.

Lubrication schedule

- Carry out the lubrication according to the instructions.

Hydraulic system

- Check that the hydraulic pump attachment screws are tightened.
- Check if the oil in the hydraulic system needs to be changed.

Add-on equipment etc.

- Maintain all add-on equipment, auxiliary equipment etc. according to the instructions supplied with it.

8.3.3 Annual maintenance

Take the crane, at least once a year, to a HIAB service workshop for inspection and maintenance.

Carry out the following maintenance at least once a year.

Hydraulic system

- Change the oil tank filler cap.
- Change the hydraulic oil.
- Replace filters.



! NOTE

If the crane is being used in hot climates the oil might need to be changed more often.

Slewing housing

- Change oil in the slewing housing.

8.4 Lubrication



WARNING

Follow the lubrication schedule exactly. If you not do so, there may be serious damage to the crane and to add-on equipment.

Type of grease

Use lithium based grease containing EP additives (consistencies 2 and 3 are recommended, depending on the climate).

Recommended greases:



BP LS EP 2, ESSO UNIWAY EP2 N, AGIP GR MU/EP3, NYNÄS UNIFETT EP.



! NOTE

Avoid grease with graphite or molybdenum-disulphide additives.

8.4.1 Lubrication schedule

	<p>Lubricate after every 16 hours of use.</p>
	<p>Lubricate after every 50 hours of use.</p>
	<p>Grease after every 50 hours of use.</p>

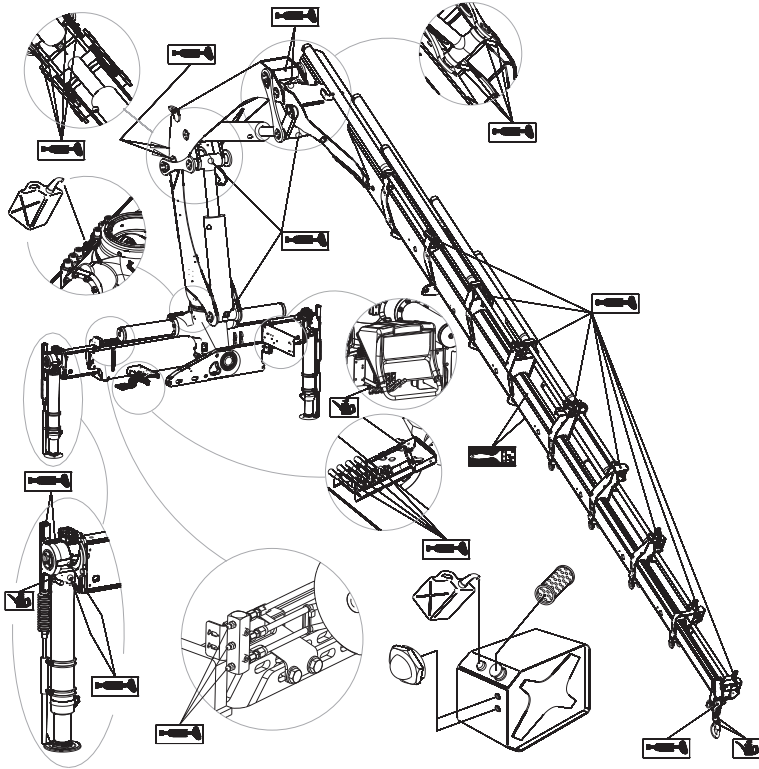

8.4.2 Lubrication of slide pads in the boom system

Side slide pads

- Extend all the extensions completely.
- Lubricate through the holes.
- Retract the extensions.

Upper slide pads

- Extend extensions with load in order to create enough clearance.
- Lubricate.

Lower slide pads

- Extend extensions without load and push slightly against the ground in order to create enough clearance.
- Lubricate.

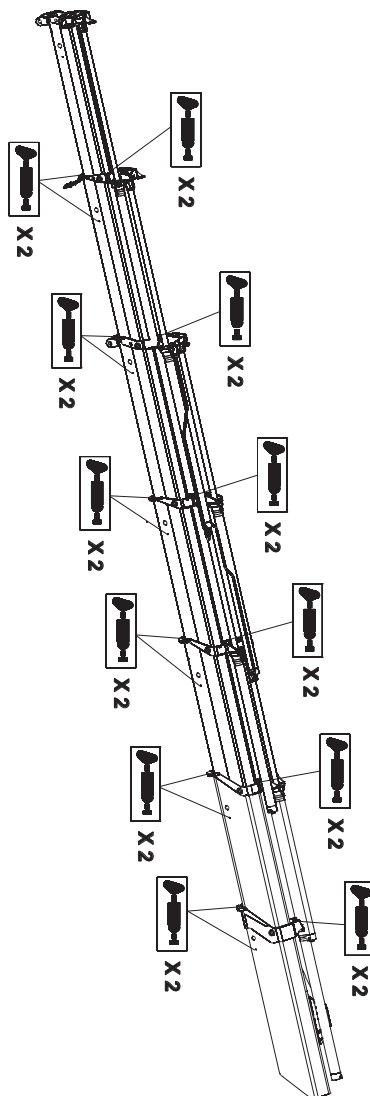

8.4.3 Lubrication of the upper column bearing



DANGER

The upper column bearing must be lubricated while the crane is slewed. If one person lubricates the upper column bearing, while another is slewing the crane: Take care that the person lubricating the bearing does not come into contact or get crushed by the crane!

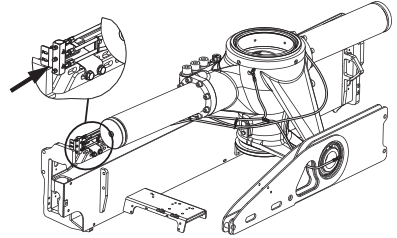

If you are lubricating the upper column bearing without help:

- Lubricate the upper bearing with a little grease.
- Slew the crane a little.
- Again lubricate with a little grease. Repeat, until the column has been slewed round completely.

8.5 Hydraulics

8.5.1 Slewing housing: checking the oil level/oil change

Checking the oil level in slewing housing

1. Check if the oil level on the measuring stick is between the maximum and minimum levels.
2. If the oil level is below the minimum level: Top up through the hole for the measuring stick with transmission oil of type MIL-L-2105C or API-GL-5, viscosity SAE-80W-90

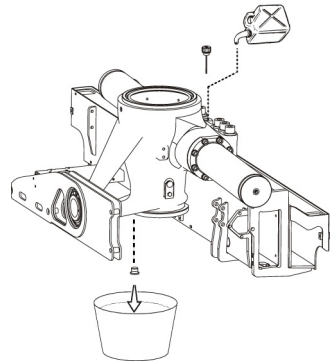

Changing oil in the slewing housing

Change the oil in the slewing house yearly!

1. The slewing housing contains about 15 litres (3.96 gallon). Use a container with sufficient capacity to receive the oil. Drain off the oil through the drain plug.
2. Refill through the hole for the measuring stick, with transmission oil of type MIL-L-2105C or API-GL-5, viscosity SAE-80W-90.
3. Slew the crane, after filling to the end positions, three times.
4. Check the oil level. If necessary top up again.

8.5.2 Replacing the cartridge in return oil filter

Return oil filter with fouling indicator



WARNING

Dirt will damage the hydraulic system

Make sure that the area around the filter is clean to prevent contamination of the hydraulic oil.

1. Unscrew and remove the cover ①
2. Unscrew and take out the cartridge ②
3. Check the condition of the o-rings and gaskets. Replace if necessary.
4. Fit the new cartridge.
5. Replace the cover ①.



! NOTE

Check that the cover is properly fitted.

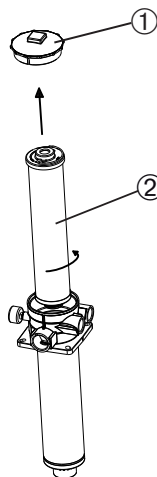

8.5.3 Replacing the cartridge in the pressure reduction filter



WARNING

Dirt will damage the hydraulic system

1. Clean the immediate surroundings of the pressure filter.
2. Dismantle the filter housing ①.
3. Remove the cartridge ②.
4. Clean the filter housing.
5. Fit a new cartridge. Also fit a new o-ring ③.
6. Reassemble the filter housing.

Replacing the cartridge in the high pressure filter [option] is performed likewise.

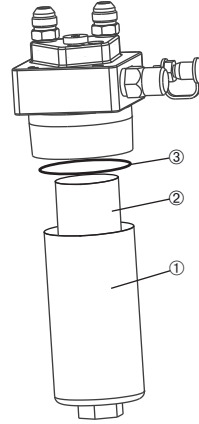

8.5.4 Checking the oil tank level

1. Place the crane and stabiliser legs in the transport position.
2. Place the vehicle on level ground.
3. Check the oil level in the tank.
4. Oil level too low:
Top up with hydraulic oil.



8.5.5 Changing the hydraulic oil



WARNING

The oil can be hot and cause injury.

1. Operate the crane for a while to warm the oil. Place the crane in the parked position. Take care that the temperature of the oil does not exceed the point where you can handle it safely. If this occurs allow the oil to cool before moving to the next step.
2. Suitable eye and hand protection must be worn while carrying out this operation, and if there is a risk for inhalation of oil mist, a mask as well.

**WARNING**

- Inhalation of oil mist: Contact a doctor.
- Skin contact: Remove polluted clothing, wash with soap and water. In the event of high pressure injection of the product, see a doctor without delay.
- Eye contact: Rinse eyes with plenty of water, see a doctor if irritation persists.

3. Drain the oil tank through the drain plug. Make sure the system contains as little as possible.

Use a container with sufficient capacity.

**! NOTE**

Ensure the waste oil is disposed of safely and in accordance with local environmental regulations.

4. Change at the same time:
 - all filters
5. Refit the drain plug.

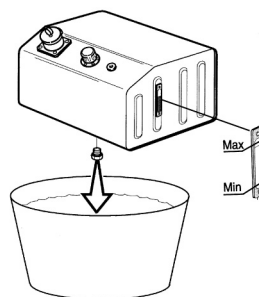
**Filling the oil tank with hydraulic oil**

The oil used for filling must be clean. Do not mix different oils.

Hydraulic oil that is approved for HIAB products must comply with one of the following standards or equivalents:

- DIN 51524 part 3
- SS 15 54 34
- ISO 11158 HV

Suppliers of hydraulic oil must verify that the quality and performance of the oil complies with the above standards.

When changing from mineral oil to a non-polluting synthetic oil, or when changing to biodegradable oil, contact a HIAB service workshop.

Viscosity of oil

The viscosity of the oil is of great importance to achieve high efficiency of the hydraulic system.

The naming of the oil in the table below: 32, 46 or 68 tells the viscosity of that oil at 40°C (reference temperature).

Viscosity of oil at 40°C	Temperature range
32	-25°C to 75°C
46	-15°C to 90°C
68	-5°C to 90°C

The recommended viscosity during normal working conditions is between 16 and 40cSt.

HIAB strongly recommend an oil working temperature below 70°C. If necessary consider an oil cooler or heater.



! NOTE

When working in arctic condition consider an oil with lower viscosity than the 32 oil in the table above.

Environmentally Friendly Oil

The environmentally friendly oils recommended for HIAB products are ester based synthetic hydraulic fluids (synthetic ester).



! NOTE

Vegetable oils do not meet HIAB's requirements and must not be used.

After filling the tank

1. Operate each crane function to its end positions.
2. Operate the crane to parking position.
3. Check and top up the oil tank to max level on the tank gauge.
4. Bleed the system.

8.5.6 Bleeding air from the hydraulic system

Bleed the air from the hydraulic system:

- after changing the hydraulic oil
- after working on the hydraulic system
- if your crane works slowly or jerkily



WARNING

Air in the hydraulic system can lead to faults and damage

To bleed air from the hydraulic system, proceed as follows:

Move each crane cylinder and each hydraulically operated piece of add-on equipment at least twice to its end positions (slowly).

8.6 Troubleshooting

8.6.1 Main fuses

If the microprocessor detects a fault, this must be rectified immediately.

Fault

The safety system does not work at all.

The indicator light next to On/Off button on the user panel is not lit, even if you press On/Off.

Probable cause

Defective fuses.

Action

Remove the covers and replace the fuses in:

- The user panel **bottom** 2x15A.
- The user panel **cover** 2x7,5A and 3x3A.

Check all cable connections and close the covers.

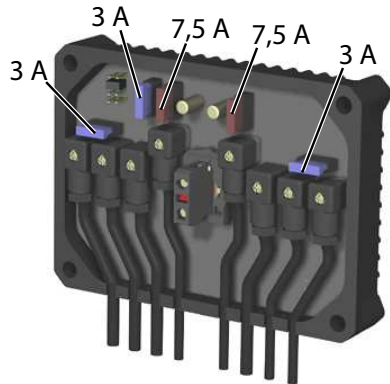
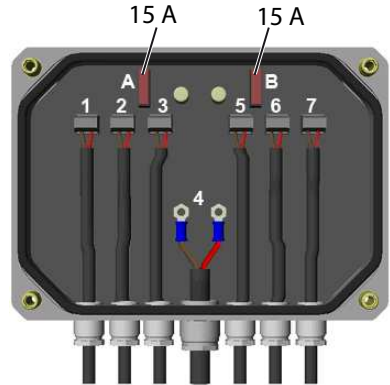

8.6.2 Faults in the HiPro crane

Faults in the crane must be rectified immediately.



DANGER

- Only correct yourself the faults that according to the table you may rectify.
- Follow the instructions exactly!
- All other faults may be dealt with only by personnel in a HIAB service workshop!

Fault	Probable cause	Action
Crane does not react to controls. Indicator lamps light up on the user panel.	Crane in an OLP situation.	Perform movements to reduce load moment. If necessary, release OLP.

Fault	Probable cause	Action
Crane does not work properly: One or more crane functions do not work or not properly. Lifting capacity is much less than normal. Operation speed is significantly reduced. The service lamp is lit.	The system has detected a fault.	Contact a HIAB service workshop.
One remote control function inoperative.	The remote control lever was not in neutral at start up.	<ol style="list-style-type: none"> 1. Push in the stop button. 2. Make sure that all levers are in neutral. 3. Pull out the stop button. Check the cables between the DA-modules.
The hydraulic pump makes a noise. Three causes: Warning! Stop using the crane immediately!	Oil tank filler cap air filter is blocked.	Clear the blockage or replace the entire filler cap.
	Oil level in the tank is too low.	Top up the oil tank and bleed the hydraulic system.
	The pump is faulty.	Go to a HIAB service workshop.
The stabiliser extensions do not slide out.	The extensions are still locked.	Unlock the extensions.
	Hydraulic fault.	Go to a HIAB service workshop.
The slewing movements are irregular or cause abnormal noises.	Insufficient oil in the hydraulic system.	Top up the oil tank.
	Insufficient oil in the slewing housing.	Top up the oil in the slewing housing to the required level.
	The upper slewing bearing is not properly lubricated.	Lubricate the bearing.
	The bearings in the slewing housing are damaged.	Go to a HIAB service workshop.

Fault	Probable cause	Action
Add-on equipment does not work properly.	Connectors not properly connected.	Reconnect the add-on equipment according to the instructions.
	Other defect.	Go to a HIAB service workshop.
Leak on hydraulic system: leaking coupling, hose or line. Danger! Keep well away from an oil leak.		<ol style="list-style-type: none"> 1. Press a Stop button. 2. Disengage the PTO. 3. Contact a HIAB service workshop.

External Display [option]

Placing

The unit shall be placed under the plastic cover together with the SPACE-box where it is protected from direct water splash.

Start up

The External display automatically starts when the SPACE system is started.



Operating modes

The display has three basic operating modes:

1. Use time mode (default)
2. Error display mode
3. Config mode

Use time mode (default)

By default the display shows how many hours the crane has been used. (Levers not centred and oil not dumped). Use time is shown on the display as:

- USE
- Number of thousands of hours
- Number of hours and a dot
- (Start over)

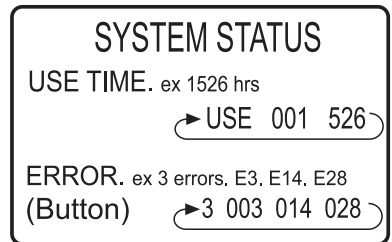

example use time=1526 hours

Error display mode

Press the button to switch to Error display mode.

Display shows \overline{Err} a short time, and then start showing errors as:

- The number of active errors and a dot.
- Each active error in turn (Blank display if no errors)
- (Start over)



The image shows a digital display with four segments. The first segment shows the number '3' followed by a dot. The second segment shows '003', the third shows '014', and the fourth shows '028'.

Press the button again to return to Use time mode.

Example: 3 active errors, 003, 014 and 028

Clear errors

In Error display mode, errors can be cleared (as in SPACE terminal) by pressing the button for 2 seconds until the clear errors symbol \overline{L} is shown in the display.

9.1 Decommissioning a crane

Cranes are designed and manufactured taking the environment into consideration. Environmental requirements and soundness have been considered when selecting the raw materials. The metal parts are designed to achieve a light and durable construction, this includes the selection of higher-quality grades of steel. When the crane is decommissioned at the end of its service life, years from now, waste will be created, which must be utilized and disposed of correctly. The crane must be decommissioned properly. Most of the crane's raw materials can be recycled.

Follow the regulations of the local authorities!

- Oil and grease must not be spilled on to the ground or released into the environment!
- Drain the oil from hydraulic cylinders, valves and hoses.

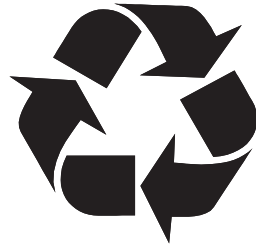

Sort the waste

- Deliver the metal parts for recycling, for reuse as raw material. These are load-bearing, structures manufactured from steel or cast iron, hydraulic cylinders and lines drained of oil, directional control valves, shafts, bearing bushes, control levers, small parts.

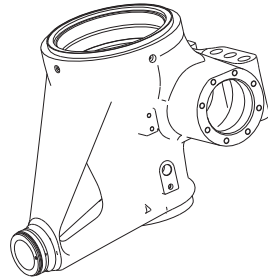

Energy waste can be utilized by incinerating it at a proper waste incineration plant

- spiral wraps, manufactured from polyethene, plastic, bearings (cleaned of lubricants) used in the column, beam system etc, manufactured from polyamide plastic.



Unsorted waste should be delivered to a landfill

- drained hydraulic hoses, electrical wires, control cables, seat, hydraulic cylinder seals, lights, small plastic and rubber parts.



Hazardous waste is delivered to a collection point for hazardous waste

- oils: hydraulic oil, transmission oil from the slewing system
- solid lubricants: greases from the joints and journal bearings
- other waste containing oils and greases: hydraulic oil filters.



10.1 Documentation

The Technical Data document shows diagrams and technical information about your specific crane

The enclosed Technical Data printed out by the installer should be stored together with this Operator's manual.