

MULTILIFT XR S

Hooklift XR21S59 CHU



USER AND MAINTENANCE MANUAL
113813003/EN
1/2018



MULTILIFT

Contents

MULTILIFT XR S CHU HOOKLIFT	5
GENERAL DESCRIPTION	6
Main components	7
Control unit	8
Signal lights of control unit.....	9
Control system.....	10
Safety instructions and safety rules	17
Safety during use - general	17
Requirements for the working area ground condition.....	20
Working area	21
Flatrack/body	23
Loading and unloading of a flatrack/body.....	25
Tipping.....	29
Before driving away	30
Safety facilities of the XR S hooklift equipment.....	31
HOOKLIFT OPERATION	33
Loading a flatrack/body	35
Loading a short flatrack/body	49
Tipping a flatrack/body	55
Lowering the tipping device	61
Unloading a flatrack/body.....	65
Loading of rear heavy flatrack/body	79
Unloading of a rear heavy flatrack/body	79
Loading of a front heavy container	79
Loading a flatrack/body onto a trailer or platform	80

>>>

>>>

LIFTFRAME USAGE	85
Appropriate ISO container types	85
Buttons on the stowage control unit	87
Fetching the lifftframe with the XR21S hook, moving it and locking it to the stowage	89
Moving the lifftframe onto the XR21S equipment's hook.....	100
Before gripping and loading the ISO container.....	110
Loading phases	111
Loading the ISO container.....	114
Unloading phases.....	130
Unloading an ISO container	132
Releasing the lifftframe from the ISO container.....	135
Moving the lifftframe onto the XR21S stowage	139
Locking the lifftframe to the stowage.....	142
Removing the lifftframe from XR21S gripping hook and leaving it on stand supports ..	145
Tipping an ISO container IS NOT allowed!.....	151
Design description	152
Technical specifications	152
Construction	154
Hydraulics.....	154
Control devices, 2GCC.....	156
EQUIPMENT	157
Locking mechanisms of the hook.....	159
Protection of main cylinder	163

>>>

>>>

MAINTENANCE	164
Service Indicator	164
Service table	168
Hydraulics service	170
Safety functions	176
General inspection	178
Electric system	180
Emergency operation	180
How to change the backlight setting of the buttons	182
FAULT FINDING	185
MULTILIFT PLC - Diagnostic Codes	185
XR S SENSORS	204
LUBRICATION	205
DELIVERY CARD	209

This manual is a translation from the original operating instructions compiled in Finnish.

MULTILIFT XR S CHU HOOKLIFT

User Manual

This manual concerns the MULTILIFT XR21S CHU hooklift equipment.

Information about the equipment.

Type of system:	<input type="checkbox"/> XR21S56 CHU	<input type="checkbox"/> XR21S59 CHU
Serial number:		
Date of commissioning:		
Owner		
Your Multilift dealer		
Service workshop:		

GENERAL DESCRIPTION

MULTILIFT XR hooklift equipment is an exchange container loading and unloading device mounted on a truck chassis. An experience of over 60 years is a proof of the reliability and versatility of the equipment all over the world.

CE Statement of Conformity

Cargotec Finland Oy Multilift has been an ISO 9001 certified company since 1995 and since 2002 the company has complied with the ISO 14001 environmental standard. Multilift guarantees that the equipment contained within this manual conforms with the EC Machine Directive.

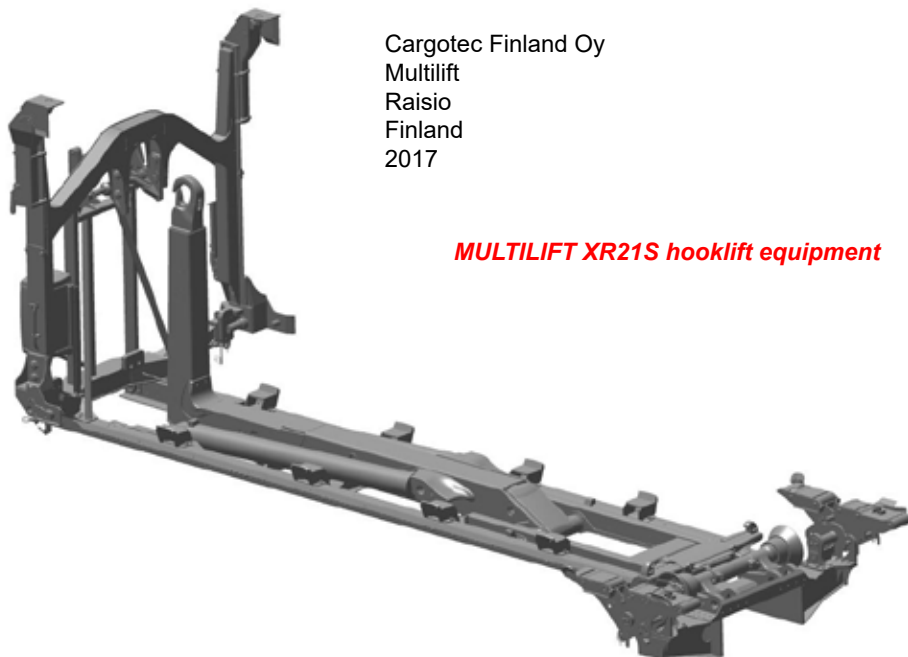

Cargotec Finland Oy
Multilift
Raisio
Finland
2017

MULTILIFT XR21S hooklift equipment

Note!

Cargotec Finland Oy reserves the right to change specifications, equipment, operating and maintenance instructions without prior notice.

Due to continuous product development some picture details may look different when compared to the actual device.

Main components

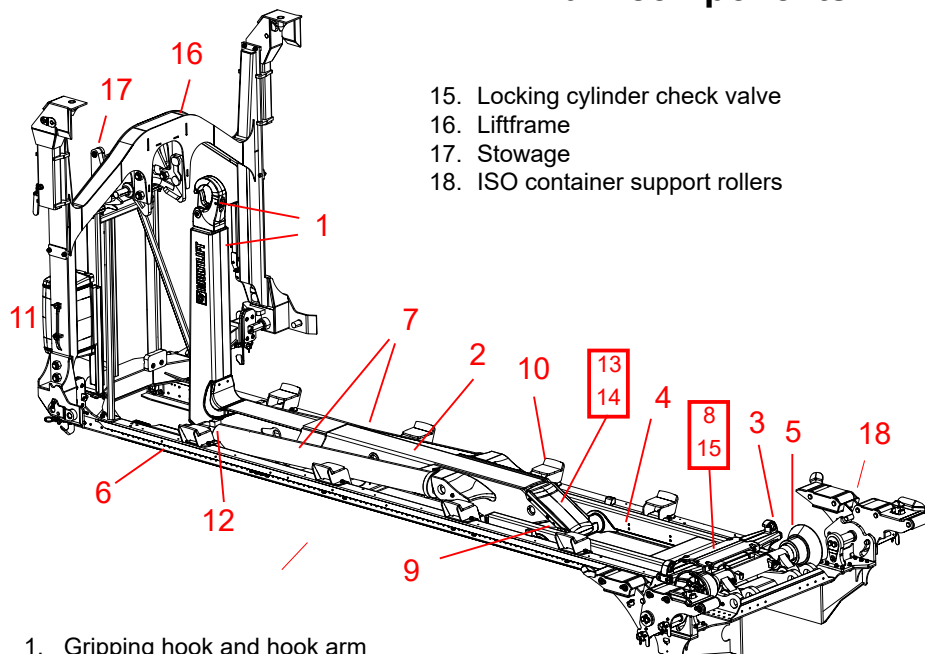

- 15. Locking cylinder check valve
- 16. Lifframe
- 17. Stowage
- 18. ISO container support rollers

- 1. Gripping hook and hook arm
- 2. Middle frame
- 3. Body locking, hydraulic
- 4. Rear frame
- 5. Rear rollers
- 6. Sub-frame
- 7. Main cylinders
- 8. Body locking cylinder (inside the frame beam of the lockings)
- 9. Mechanical tipping lock
- 10. Body support
- 11. Control valve
- 12. Load holding valve of the main cylinder
- 13. Telescope cylinder (inside the middle frame)
- 14. Double check valve of the telescope cylinder

Control unit

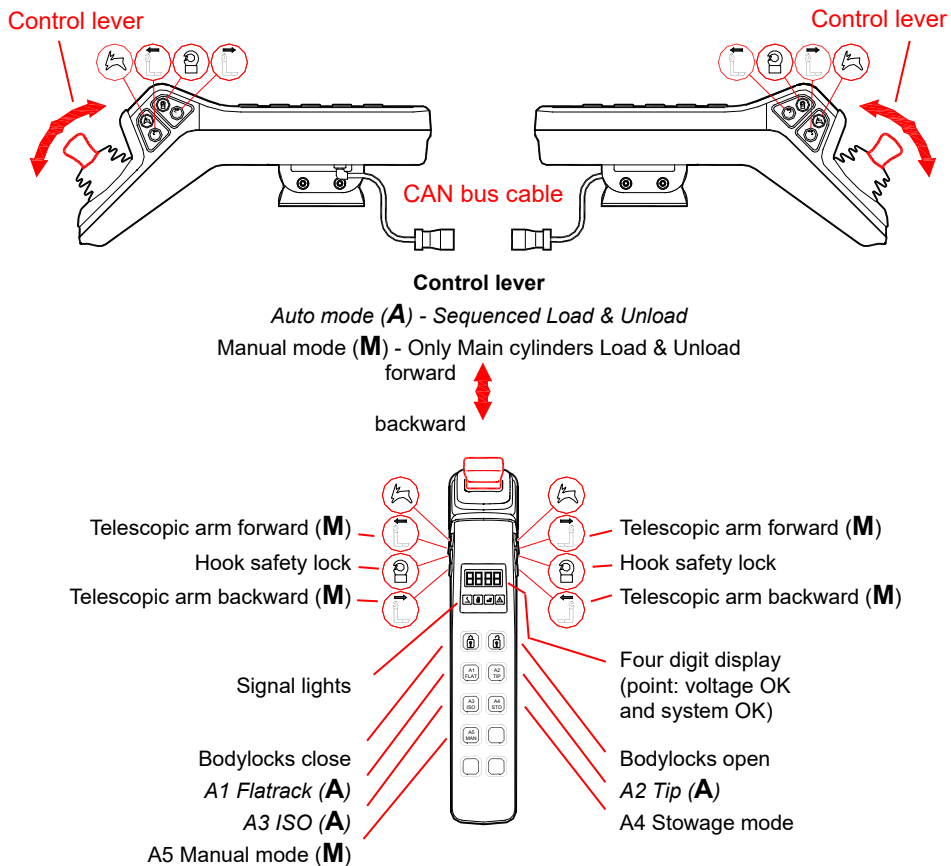

The buzzer which is fitted in the control unit is active as follows:

- In Auto modes (A1, A2, A3) when the telescopic arm isn't fully forward.
- In Manual mode (A5) when the telescopic arm isn't in fully forward.
- In Stowage mode (A4) when the telescopic arm isn't in fully forward.

Signal lights of control unit

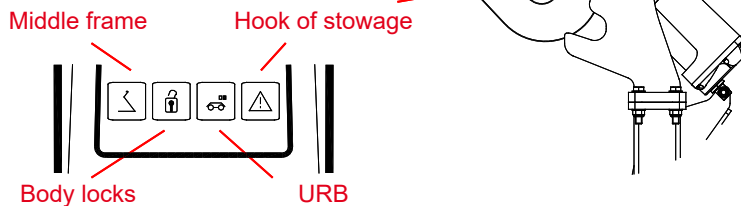

SIGNAL LIGHT	Off	Blinking	On
Middle frame	Middle frame down	Middle frame almost down (floating)	Middle frame is raised
Body locks	Body locks are closed or the pull limiter is engaged	Body locks are in transitional position	Body locks are open or the pull limiter is not engaged
Under-run bar	Under-run bar is fully extended	Under-run bar is in transitional position	Under-run bar is fully retracted
Stowage hook	Stowage hook down (in)	Stowage hook in transitional position	Stowage hook up (out)

Control system

CONTROL UNIT

All the switches needed to operate the XR21S -equipment can be found on the control unit.

A movement (manual mode) or a series of movements (automatic mode) is selected in the control unit.

Moving the control lever on the control unit enables movement or series of movements in different directions.

The four digit display on the control unit gives information about faults, errors and different phases of operation.

CONTROL SYSTEM LOGIC

The operations are controlled by a logic, which has been programmed into the control system. An approach switch sends signals to the logic, giving it information about the operational phases of the equipment.

The device can be either driven in **automatic mode** (A1 - A3), or in **manual mode** (A5), one movement at a time.

If a fault occurs (e.g. approach switch malfunction), the device will stop in automatic mode. In manual mode it will continue to run, except for the section causing the error. An error code identifies the cause of the interruption.

The error can be reset by turning off the power (ignition key) and having another go.

SYSTEM OPERATION IN AUTOMATIC MODE

In automatic mode the movements are split into the following phases:

1. Loading and unloading a flatrack/body

The movements take place in mode A1. Push the A1 button on the control unit for 2 seconds. When the mode is engaged, A1 will blink on the control unit display. The mode will disengage by pushing the A1 button again, or automatically after 10 minutes if no operations have been used during this time.

A1 mode cannot be selected when the telescopic arm is further forward than the "FLATRACK HOME POSITION". Code "d040" is displayed on the control unit display when attempting to select the mode.

For unloading the control lever is pulled back, which results in successive movements of the equipment. The rear rollers must be in "FLATRACK POSITION".

First the body locks open. After this the horizontal movement and the hook moves backwards. Tipping lock opens as the horizontal movement comes toward the back. The main cylinders start after the horizontal movement, and they continue until the entire flatrack/body is on the ground and the control lever is released.

Loading is split into similar stages. It takes place as successive movements, by holding the control lever pushed forward.

The movements are as above, but in opposite order.

The main cylinders are released (floating) when the flatrack/body is about 60 mm above the body supports, and the final phase of loading is dampened.

Horizontal movement is the final operation and it can be stopped by releasing the control lever, when the flatrack/body is in the correct place (short ones).

Movement of the telescope cylinder during flatrack/body change is restricted to approx. 350 mm before the extreme front position ("FLATRACK HOME POSITION").

The locks will engage automatically.

The biggest horizontal movement is 1100 mm (in manual mode).

2. Tipping and lowering the tipping device

The movements take place in mode A2 (push the A2 button on the control unit for 2 seconds). When the mode is engaged, A2 will blink on the control unit display. The mode will disengage by pushing the A2 button again, or automatically after 10 min if no operations have been used during this time.

Mode cannot be selected when the telescopic arm is more to the front, than "FLATRACK HOME POSITION or CONTAINER HOME POSITION". Code "d040" is displayed on the control unit display when attempting to select the mode.

The operations are the same as those in manual mode, except:

When tipping is started by pulling the control lever backwards, the logic ensures that the locks are engaged by activating the BODYLOCKS CLOSE function for approx. 0,5 s. After this the main cylinders lift the flatrack/body if the body locks are closed, the pull limiter is engaged and the under-run bar is retracted.

Afterwards, as the flatrack/body is being lowered, movement speed is automatically reduced before the flatrack/body is lowered onto the body supports.

3. Loading and unloading an ISO container (Liftframe must be used)

The movements take place in mode A3. Push the A3 button on the control unit for 2 seconds. When the mode is engaged, A3 will blink on the control unit display. The mode will disengage by pushing the A3 button again, or automatically after 10 min if no operations have been used during this time.

Mode cannot be selected when it is more to the front, than the front position of flatrack/body change (approx. 350 mm behind the far-front position). Code "d040" is displayed on the control unit display when attempting to select the mode. The liftframe ratchets must also be attached to the stowage, "d019" is visible on the control unit display.

For unloading the control lever is pulled back, which results in successive movements of the equipment. Rear rollers must be in "CONTAINER MODE".

The TWIST LOCK-locks need unlocking. First the body locks open.

After this the horizontal movement and hook movement backwards take place. Tipping lock opens as the horizontal movement comes towards the back.

The main cylinders start after the horizontal movement, and continue until the entire ISO container is resting on the ground and the control lever is released.

Loading is split into similar stages. It takes place as successive movements, by holding the control lever pushed forward.

The movements are as above, but in opposite order. The main cylinders are released (floating) when the flatrack/body is about 60 mm above the body supports, and the final stage of loading is dampened.

Horizontal movement is the final operation and it can be stopped by releasing the control lever when the flatrack/body is in the right place (short containers). Movement of the telescope cylinder during ISO container change is restricted so, that the corner locks at the back end of the ISO container meet the TWIST-LOCKS at the back end of the ISO container support rollers ("CONTAINER HOME POSITION"). The twist locks do not engage automatically.

The purpose of these phases is:

1. Horizontal movement at the beginning of loading and unloading is done by a sliding horizontal movement. Because of this the front of the flatrack/body is not lifted during horizontal movement, as is normally the case during tilting. As a result the horizontal movement can be stopped at any time, depending on the flatrack/body length.

SYSTEM OPERATION IN MANUAL MODE

Manual mode must be used in special situations, such as handling longer or shorter flatrack/bodies than usual, handling containers in shallow spaces or on uneven ground and loading or unloading them on/from a platform or a trailer.

The movements take place in mode A5 (push the A5 button on the control unit for 2 seconds). When the mode is engaged, A5 will blink on the control unit display. The mode will disengage by pushing the A5 button again, or automatically after 10 min if no operations have been used during this time.

The horizontal movement is prevented when it is more to the front than the front position of flatrack/body change (approx. 350 mm behind the far-front position = "STOW/UNSTOW POSITION"). The liftframe ratchets must also be attached to the stowage. Otherwise "d019" will be visible on the control unit display.

In manual mode the main cylinders are controlled by moving the control lever to the front and the back. If the body locks are open, the XR21S -equipment is in loading/unloading mode. If they are closed, the XR21S -equipment is in tipping mode. See terms of use in mode A2.

The telescope cylinder is controlled by rocker switches on the sides of control unit, by pushing its front or back. The body locks must be open. The horizontal cylinder stroke has not been restricted.

The movements in manual mode should be phased as in automatic mode.

As explained earlier, the horizontal movement is long, and during flatrack/body change it has been restricted to approx. 350 mm before the far-front position.

CHANGING OPERATION IN DIFFERENT SITUATIONS

Each **operation can be stopped at any time** by releasing the switch, and continued or changed depending on the operation phase (but not changed e.g. from tipping to changing the flatrack/body) by going to the desired operation and pressing its switch.

Changing the control method (automatic mode/manual mode)

1. Changing from automatic mode to manual mode
The control method can **always** be changed to manual, under all circumstances.
2. Changing from manual mode to automatic mode.
 - 2.1 Automatic mode can be engaged, if the tilting movement is fully in the front position, the locks will close
- tipping and unloading are possible.
 - 2.2 Automatic mode cannot be engaged if the tilting movement is in a position other than front position, a warning buzzer can be heard in the cabin.

AUTOMATIC MODE should be used whenever possible.

Automatic mode can be used during loading and unloading of containers with widely used lengths.

The flatrack/body length in automatic mode should be:
at least 4,6 m (G-size - 0,7 m) G-size = geometric length of the equipment 5,3 m,
max. 6,3 m (G-size + 1,0 m) measurement from the middle line of the hook to the middle of the rear rollers

Shorter or longer containers must be handled in manual mode.
Even containers with these dimensions should be handled in manual mode when loading on uneven ground.

Normally automatic mode can always be used during tipping.

Horizontal movement of the XR21S equipment is restricted for safety reasons, i.e. standard containers won't collide with the equipment on level ground.

As stated before, the user friendly automatic mode should always be used, whenever the flatrack/body length allows it.

Manual mode should always be used in special cases (loading in shallow spaces, loading a flatrack/body on a trailer or a platform).

Safety instructions and safety rules

MULTILIFT XR hooklift equipment was developed for the loading, unloading, tipping and transporting of removable containers/bodies on vehicles. All other use of the Multilift hooklift equipment is strictly forbidden. Multilift accepts no liability whatsoever with regard to such other use.

The hooklift equipment meets all safety and stability standards that apply at the moment of its delivery from the factory. Use the hooklift equipment only if it is in good condition, and only for the purpose for which it was designed and in accordance with the instructions and guidelines specified in this manual.

Cargotec Finland Oy Multilift accepts no liability whatsoever for any loss or damage caused by the failure to strictly adhere to the safety instructions specified in this manual or due to carelessness during the operation, adjustment, maintenance or repair of the hooklift equipment. Depending on the specific working conditions, additional safety instructions may be required.

Safety during use - general

The driver must be familiar with the contents of this manual and should strictly follow the directions and instructions. He must see to it that his XR hooklift equipment is technically in perfect condition. Control of the suspension, condition of the tyres, tyre pressures, weak or poor condition of the flatrack/body or unsuitable loading of it, are all his responsibility. The driver must handle the XR equipment with care. For example during loading and unloading the front wheels of the truck must not be lifted up from the ground.

XR hooklift equipment may only be used when sitting on the driver's seat.

If it is necessary to leave the cabin during loading, unloading or tipping, always engage the parking brake and disengage the power take-off.

In the vicinity of the control units there must be no obstacles or loose objects that might accidentally activate unit's functions.

If the equipment has not been used for two weeks or longer, all safety functions must be checked before the equipment is used again.

Avoid the unnecessary use of the main pressure relief valve. Heating up of the oil reduces the quality of it and results in shorter life span of retaining rings and gaskets.

In subzero temperatures ($< 0^{\circ}\text{C}$) it is recommended to let the pump idle for around 1 minute in order for the hydraulic oil to be warmed up.

During the use of the equipment the engine noise will increase due to additional loading. Noise level will also increase if the flatrack/body is pulled along the ground during loading or unloading of it.

When the equipment is used carefully and in a sensibly planned manner, the noise level can be kept lower.

Take care that the truck or the hooklift is not overloaded. Observe the factory data for the truck with regard to maximum permissible axle load/GVW. See also the axle load calculations!

Strong winds will have an effect on the operation during loading, unloading or tipping of the flatrack/body.

The locking signal light is red and it is lit when the body and tipping locks are OPEN (changing a flatrack/body). The light blinks when the body and/or tipping locks are in a transitional position, i.e. their movement is prevented.

If the light doesn't go out when the locks are engaged, or if it isn't lit when they are open, investigate and fix the cause immediately.

If the vehicle is left in a public place, the demountable should always be left in transport position on top of the sub frame.

Check that the flatrack/body is suitable for the load to be transported.

Ice can build up in the equipment in subzero temperatures 0°C . This may hinder or prevent some movements.

Note!

Any faulty operation or movement must be stopped immediately by shutting off the oil supply of the hydraulic pump.

Never keep hydraulics engaged if the auxiliary device needing it is not in use.

The switch unit outside the cabin is equipped with an emergency stop switch.

Let the engine run at idle speed at the beginning and end of movements, otherwise follow the recommended pump speed.

The pressure settings of the equipment should not be changed.

Requirements for the working area ground condition

Before you start loading, unloading or tipping, you must inspect the following:

- the ground must be firm and free from potholes into which the truck could move during operation
- the ground must not be slippery
- the ground must be level

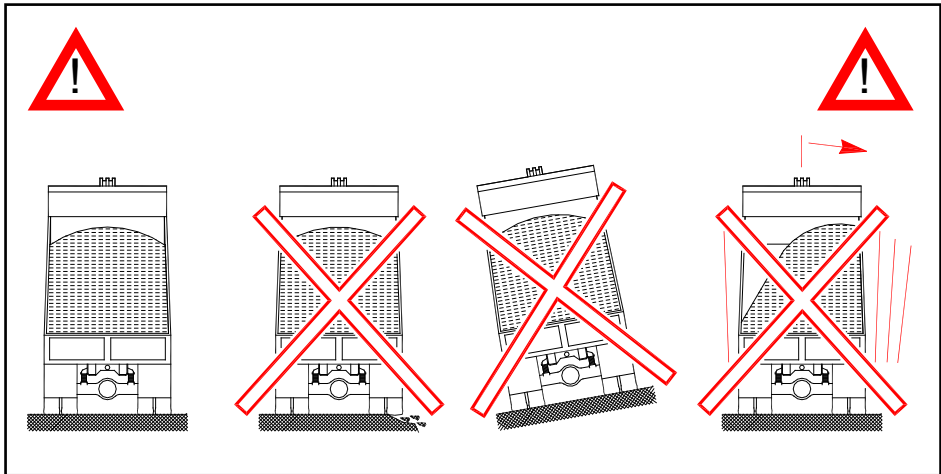

Working area

Load or unload only where there is sufficient space; this also applies to free height. **There must be at least 10 m free space at both sides of the vehicle.**

Check the vicinity for possible dangers.

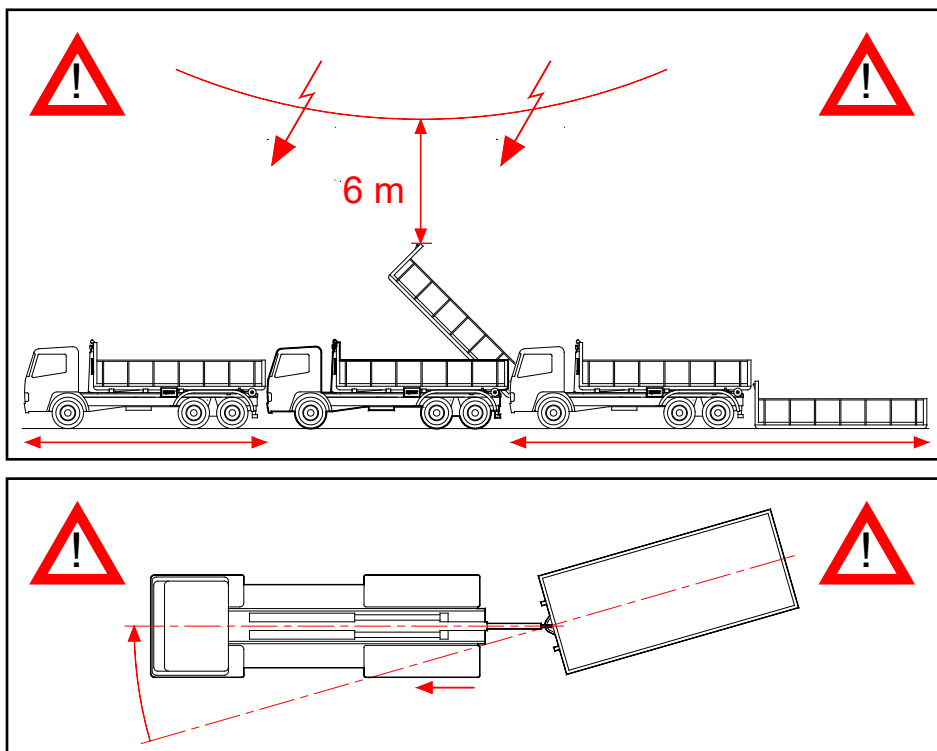

When loading, the flatrack/body must be placed in line with the driving direction of the truck.

If working in the dark, use working lights shining backwards in addition to the standard truck lights.

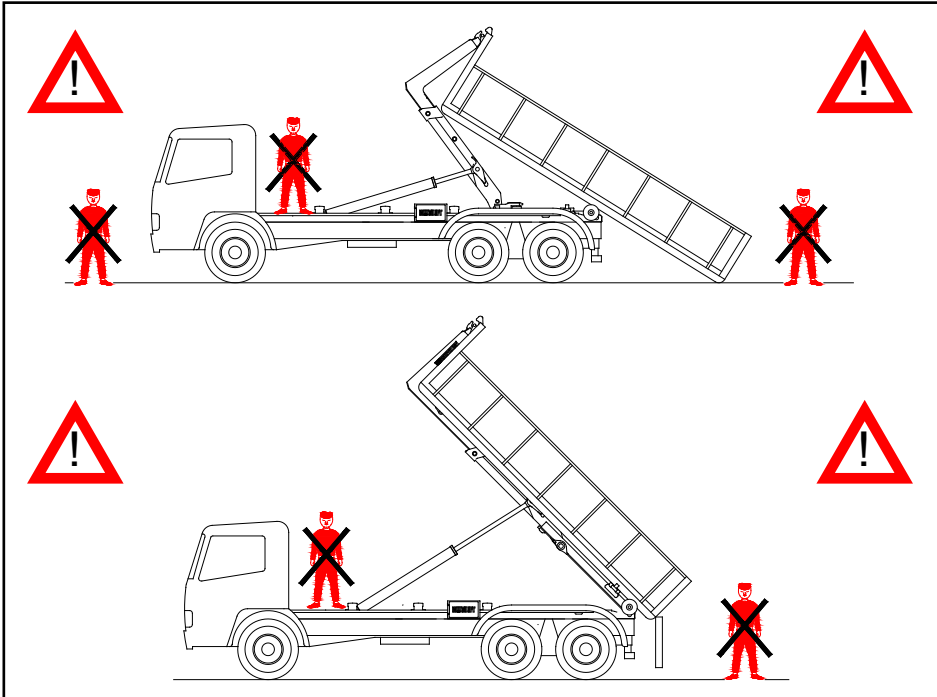

It is the responsibility of the driver to ensure that there are or there will be no other persons within the danger zone of the working area. It is strictly forbidden for anybody to be close to the truck or the flatrack/body.

Tip Mark out the working area, for example, with cones.

**In case of emergency:
Shut off the oil supply of the hydraulic pump.**

Flatrack/body

The demountable body can be a NATO STANAG 2413 flatrack, DIN 30722-1/2 flatrack (max length 6650 mm), DIN 14505 flatrack (3765 mm locks, max 6650 mm), ISO IC & ICC container or Swiss Standard pallet.

Check to be sure that the flatrack/body is suitable for the load to be transported. Generally each flatrack/body has a model plate (ID) on which the length and permissible load are specified.

Before picking up the flatrack/body, check that the hook height (H), tunnel height (T) and the width (W) correspond with the XR hooklift dimensions and that the notches for the body locks are in correct positions.

If there is even the slightest doubt of the flatrack/body dimensions, measure them first in order to prevent the XR equipment and the flatrack/body from being damaged.

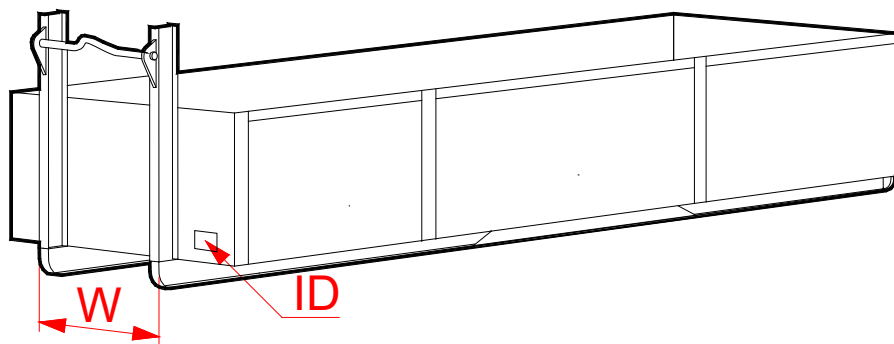

Gripping height (H), tunnel height (T) and width (W) of the flatrack/body can vary from one flatrack/body to another. Note that they are country specific dimensions. If there is doubt about the origin of the flatrack/body, the tunnel height and width must be checked in order to ensure that they are compatible with those of the XR equipment.

The condition of the flatrack/body must be checked regularly. Especially if you are going to use a type of flatrack/body with which you are not familiar. In particular, check the condition of the locking points and the condition and position of the lifting hook.

The maximum allowed wear of the lifting hook is 10 % from its nominal diameter. Nominal diameter must be checked with the hooklift equipment supplier.

The longitudinal rails at the bottom of the flatrack/body are under heavy burden. Carry out daily checks of these components for wear or damage.

If the flatrack/body is frozen to the ground, do not pull it loose by using the XR hooklift equipment. Use, for example, a forklift truck.

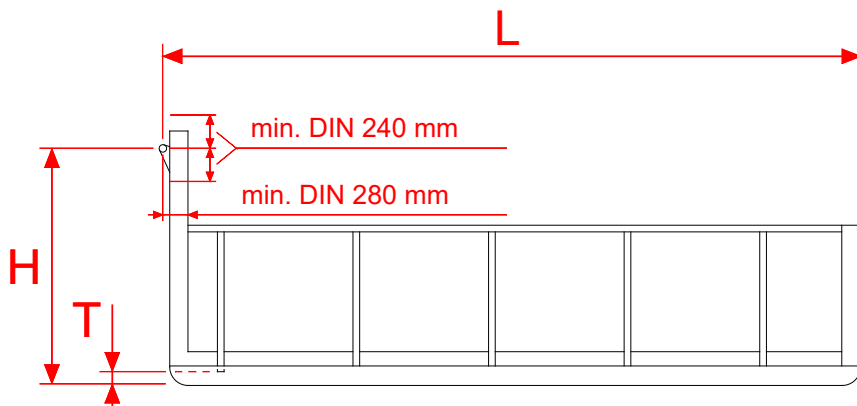

Loading and unloading of a flatrack/body

Flatrack/body loading is normally done by using the middle frame and the sliding frame.

Ensure before loading that the length of the flatrack/body is suitable for your XR hooklift equipment

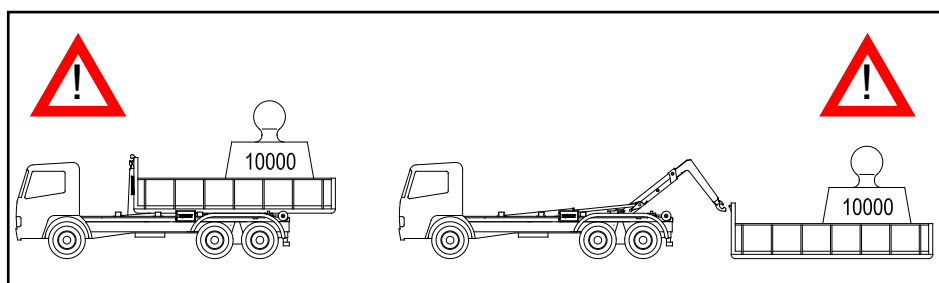

Loading of a rear heavy flatrack/body requires special care.

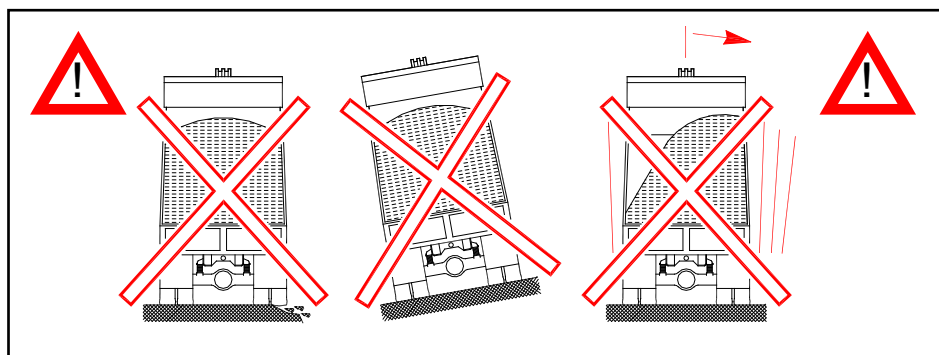

Never load, unload or tip a flatrack/body when the load is heavier to one side or the ground is sloping.

Ensure that the load's centre of gravity is as low as possible and that it is in the middle of the flatrack/body and evenly distributed. If the load must be secured, do this when the flatrack/body is on the ground.

Ensure before loading or unloading of the flatrack/body that all the removable equipment are safely fastened and that the load space tail gate, side doors and the load's fastening have been checked.

Reverse the truck as slowly as possible to avoid damaging the flatrack/body, the load or the XR hooklift equipment.

If the truck is not in line with the flatrack/body, position the flatrack/body in line by lifting the front end of it approx. 10 cm and pulling it forward by truck. This will prevent the flatrack/body from being pulled outside the rear rollers, and the hooklift and rear lights being damaged.

When moving the flatrack/body to get it in line with the truck, first remove all obstacles in front of the flatrack/body.

When loading or unloading a flatrack/body, ensure that the hydraulic body locks are open. The corresponding control unit signal light is lit when the locks are open.

Remember that the maximum permissible speed of the pump = the recommended engine speed. Let the engine run at idle speed while switching the hydraulic body locks on and off. Each movement must begin and end at idle speed of engine and at low speed of the tipping cylinders. In addition the recommended pump speed (= engine speed) must not be exceeded.

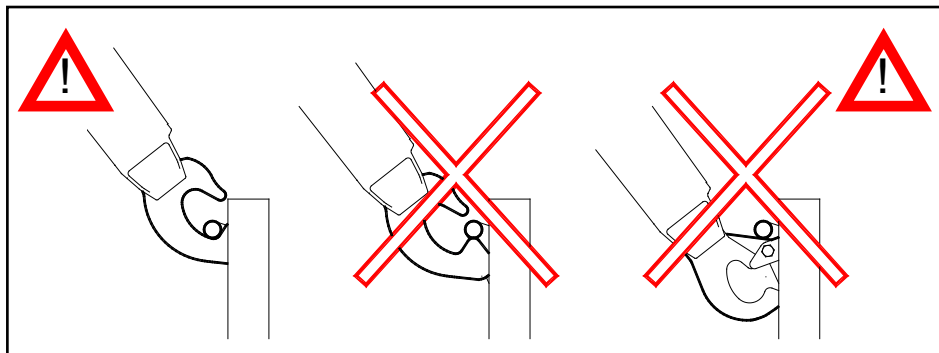

Before picking up the flatrack/body, the gripping bar of the flatrack/body must be properly inside the lifting hook. In this way you prevent the flatrack/body from falling. The situation must be checked by lifting the flatrack/body approx. 10 cm and after that checking physically and visually that the flatrack/body gripping bar is inside the lifting hook.

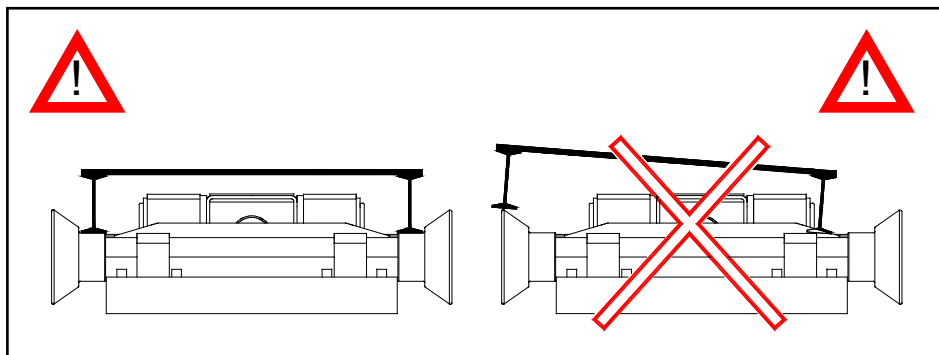

When loading and unloading a flatrack/body, be sure that it is running in line between the rear rollers.

Stop the movement of the middle frame immediately when the flatrack/body is on ground. If the hooklift movement is not stopped in time, the truck rear end will be lifted up from the ground, which will cause damaging of the flatrack/body, truck or the hooklift equipment.

The operation of the hooklift must take place in the correct sequence, one operation at the time.

During the loading operation, the handbrake should not be activated UNTIL THE REAR END OF THE FLATRACK/BODY IS LIFTED FROM THE GROUND!

When unloading, the hand brake should be released WHEN THE REAR END OF THE FLATRACK/BODY TOUCHES THE GROUND!

When loading, unloading or tipping a flatrack/body, check that there are no people too close to the operation, and check for any possible unusual or disruptive movements or sounds caused by the flatrack/body. If you notice anything like this, STOP THE OPERATION. Find out the reason for this carefully. Do not continue the operation before the cause has been established! Failing to do this could result damaging the flatrack/body or the XR equipment. The disruption must be remedied before the operation is continued.

NEVER LOAD, UNLOAD OR TIP IN DANGEROUS SITUATIONS:

- When the load is heavier to one side of the body
- Illegally heavy load
- Sloping or slippery ground
- Soft or crumbly ground under the truck wheels
- Strong side wind, over 20 m/s (70 km/h)
- Frozen or stuck load

TRUCK PROBLEMS:

- Weak springs on one side
- Poor condition of tyres.

Tipping

If the flatrack/body overhang is too much, the rear end of the flatrack/body will touch the ground when tipping and the flatrack/body, truck or hooklift equipment will be damaged.

In very cold weather the load might freeze tight on the flatrack/body. In that case it must be freed before tipping. Note that the load might come out in large chunks!

NEVER TIP UNDER THE FOLLOWING CIRCUMSTANCES:

- Flatrack/body is top heavy at the front end or at either side.
- Load is frozen or only partially loose
- Ground is slippery or uneven
- Strong side wind, which exceeds over 20 m/s

If it is necessary to drive with the tipping device up, pay attention to the vicinity regarding the height of the hooklift equipment / flatrack/body with respect to the surroundings like bridges, tunnels and overhead power lines! Drive slowly and be extra careful.

If the tipping angle is changed during driving, the gearbox bears an extra burden, and the truck can make unexpected motions on a slippery surface.

Before driving away

Before you drive off, always check the following:

- Hydraulic body locks must be closed; signal light on the control unit must no longer be lit. The locking hooks must be tight on the flatrack/body, i.e. on the lower flange of the flatrack/body frame beams or in the specific notches (if provided). Check this on both sides of the truck.
- PTO must be disengaged.
- Check that the flatrack/body doors are closed.
- Check that the load is secured and covered.
- All red flatrack/body signal lights on the control unit / instrument panel must be out.
- If a signal light on the control unit does not go out when the body locking system is locked, there is a malfunction which must be corrected immediately.
- When there is no flatrack/body mounted, the XR S hooklift equipment must be positioned in its transport position on the sub-frame both during driving and parking. Never drive the truck with the hooklift in any position other than the transport position.
Driving with main cylinders in some other position than transport, will damage the XR S equipment and/or main cylinders (leaks). Drive speed with the hooklift in the before mentioned position must not exceed 30 km/h.

Safety facilities of the XR S hooklift equipment

To increase safety, the control system has safety features to prevent incorrect movements of the body so that the load can be kept under control.

The hydraulic cylinders are provided with load holding valves that ensure a controlled movement of the XR S equipment. In addition these valves serve as a safety feature in case of the failure of hydraulic hoses.

The following functions have safety features:

- Hydraulic body locks cannot be opened during tipping.
- Hydraulic body locks cannot be closed during loading and unloading.
- If the body locks are closed, it is not possible to move the hook arm.
- Moving the hook arm is not possible during tipping.
- When tipping, the rear frame and the middle frame are locked together by the tipping lock. The lock operates mechanically.
- Tipping action cannot be initiated if the hydraulic body locks are open.
- The hook arm stops in two positions:
 - Fully forward - this is when carrying an ISO container OR during the stowing/unstowing operation = CONTAINER HOME POSITION.
 - Approx 350 mm rearwards - this is when carrying a flatrack/body OR when empty = FLATRACK HOME POSITION.

HIAB shall at all times have the right to:

- install, maintain and dismantle automated remote diagnostics system or similar sensor-based system (the “System”) in and from the Equipment; and
- access, send, receive, collect, store and use any and all information and data gathered or created by such System including but not limited to information concerning operation, operating environment, movement, condition, logon, location and similar information relating to the Equipment (the “Information”).

The Customer shall not in any way remove or alter the System, nor interfere with the use of the System or the Information. The System and the Information and all their further developments shall at all times be and remain the exclusive property of HIAB without granting any right or license to the customer.

HOOKLIFT OPERATION

Before loading a flatrack/body

CHECK THE POSITION OF THE ISO CONTAINER SUPPORT ROLLER ON THE XR21S -EQUIPMENT BEFORE LOADING A FLATRACK/BODY!

THE ROLLER CRADLES MUST BE IN FLATRACK POSITION (image 1) WHILE HANDLING FLATRACKS/BODIES.

If the roller is in the ISO container position (picture 2)

- 2 Pull the longer roller locking pin out to the point where the roller can be moved (do not pull the whole locking pin out).
- 3 Turn the roller to an upright position. Lock the roller to this position by pushing the locking pin back in.
- 4 Pull the shorter roller locking pin off, lower the front part of the roller, and lock it to down position with the locking pin (hole A).
- 5 **After the operation both locking pins must be locked to their correct positions with lock latches (picture 5).**

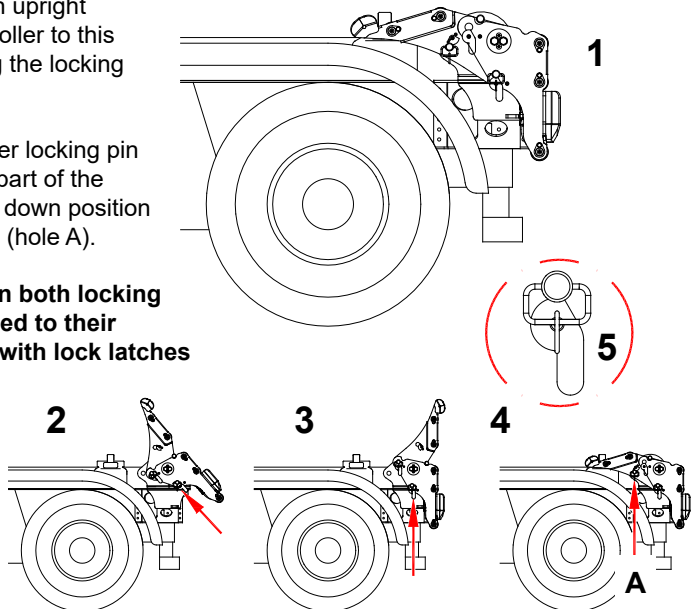

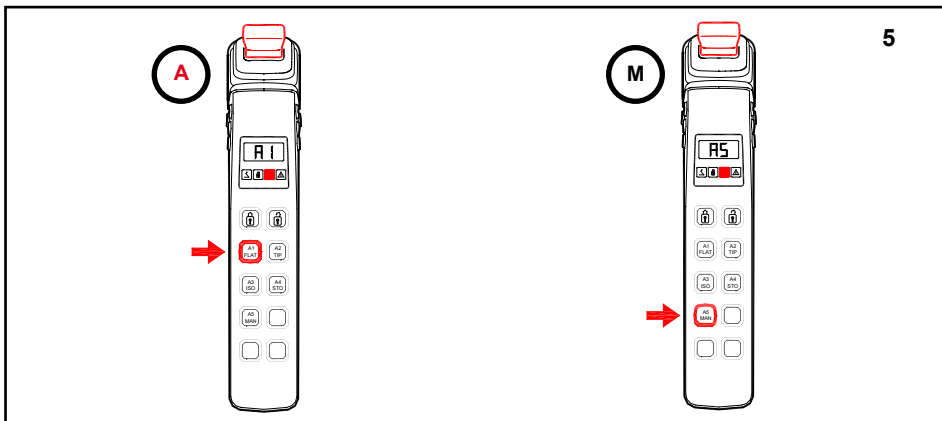
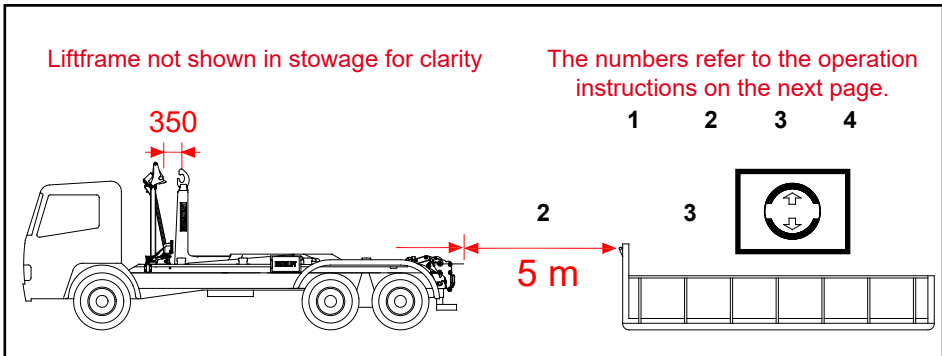

Loading a flatrack/body

XR21S EQUIPMENT IS IN TRANSPORT POSITION WHEN STARTING MOVEMENTS
During flatrack/body change the horizontal movement is in flatrack home position (approx. 350 mm behind the stow/unstow position).

The recommended pump running speed is between 1000 - 1400 k/min. Let the engine run at idle speed at the beginning and end of movements and when using the locks.

NOTE! Unnecessary use of the main pressure relief valve should be avoided, because this may overheat the oil.

1. **See the safety instructions before loading.**
2. **Reverse the truck carefully close to the flatrack/body.**
Stop it about 5 meters from the flatrack/body gripping bar.
3. **Engage the parking brake.**
4. **Engage the hydraulic pump.**

AUTOMATIC MODE A1

A

- 5 **Choose automatic mode A1**
- push the A1 button for approx. 2 s.

MANUAL MODE A5

M

- 5 **Choose manual mode A5**
- push the A5 button for approx. 2 s.

CXXX / dXXX
Safety codes

>>>>>>>>>>

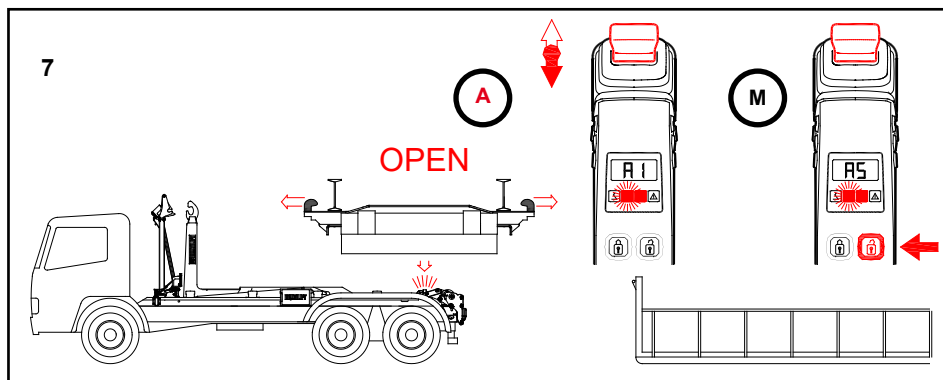
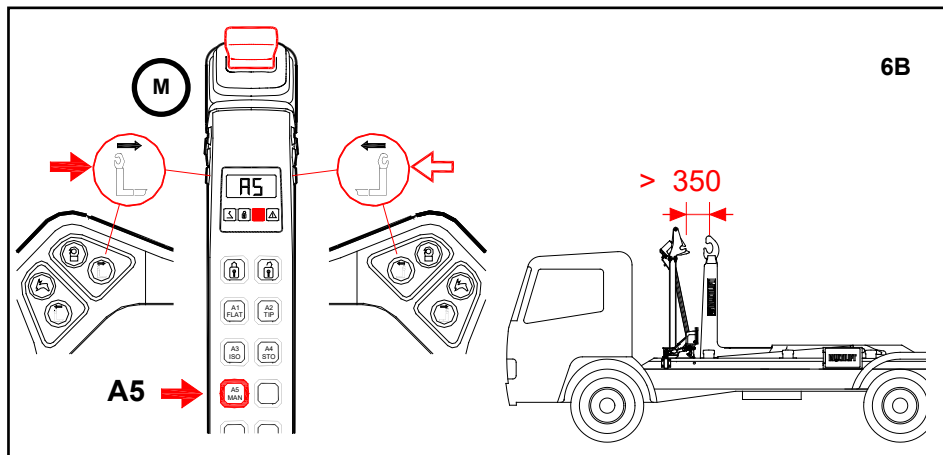
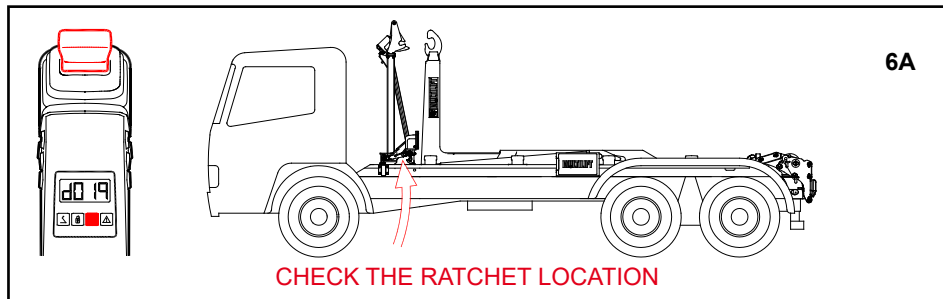

- 6A. If it seems impossible to select the mode and code "d019" is displayed on the control unit, make sure that the attachment joints of the lifftframe ratchets are attached to the stowage.

M

- 6B. Select manual mode A5 in case the horizontal movement has been driven to the stow/unstow position, in front of the flatrack/body home position.
- push the A5 button for approx. 2 s.
 - push the rearmost button in the bottom row on the either side of the control unit
 - horizontal movement slides backwards (cylinder in)
 - stop the horizontal movement after it has moved at least 350 mm backwards

A

7. **Opening body locks**
- *move the control lever slowly backwards*
 - *the body locks open*
 - *"locks not closed" signal light on the control unit is lit, when the locks are fully open.*

M

7. **Open the body locks**
- push the "bodylocks open" button
 - "locks not closed" signal light on the control unit is lit, when the locks are fully open.

CXXX / dXXX

Safety codes

>>>>>>>>

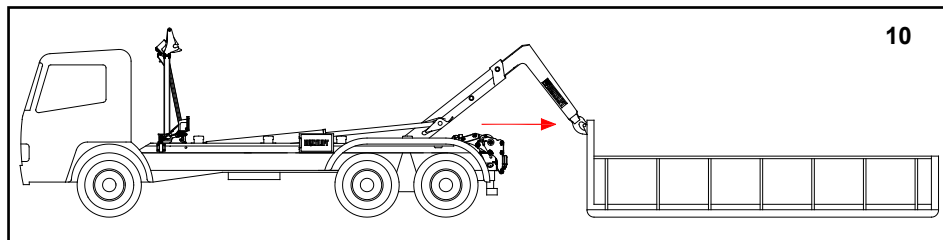
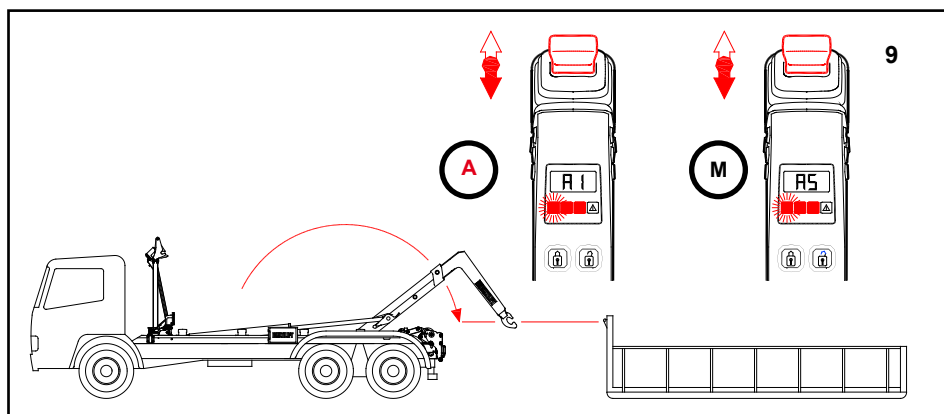
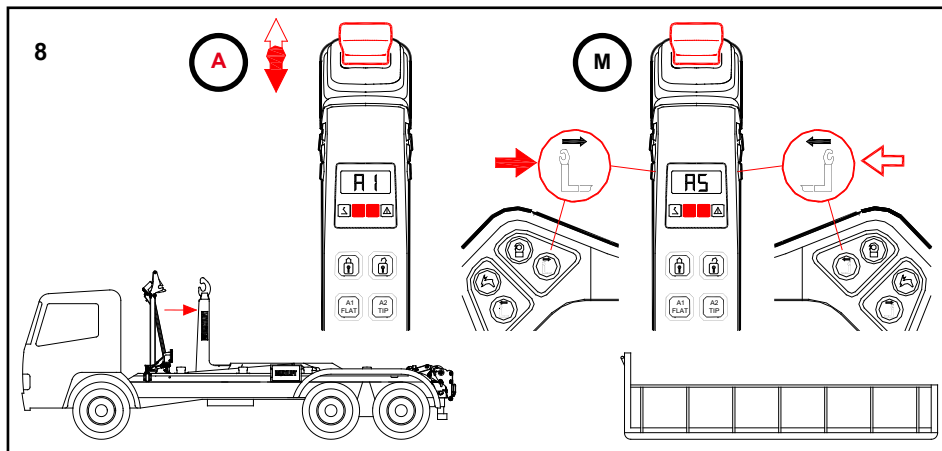

A

8. **Horizontal movement into rear position**

- keep the control lever in rear position
- horizontal movement slides backwards (cylinder in)
- mechanical tipping lock opens when the hook frame is in rear position.

9. **Middle frame back**

- keep the control lever in rear position. Middle frame turns back (main cylinders out).
- "frame not down" signal light is lit, when the middle frame is lifted off the sub frame
- stop the movement by releasing the control lever, when the hook is slightly below the flatrack/body gripping bar.

M

8. **Drive the horizontal movement into rear position**

- push the rearmost button in the bottom row on the either side of the control unit
- horizontal movement slides backwards (cylinder in)
- mechanical tipping lock opens when the hook frame is in rear position.

M

9. **Drive the middle frame back**

- drive the middle frame back by moving the control lever back (main cylinders out).
- "frame not down" signal light is lit, when the middle frame is lifted off the sub frame
- stop the movement by releasing the control lever, when the hook is slightly below the flatrack/body gripping bar.

10. **Gripping the flatrack/body gripping bar**

(manual mode A5 and automatic mode A1)

- reverse the truck carefully, until the hook frame comes close to the flatrack/body gripping bar.

CXXX / dXXX

Safety codes

>>>>>>

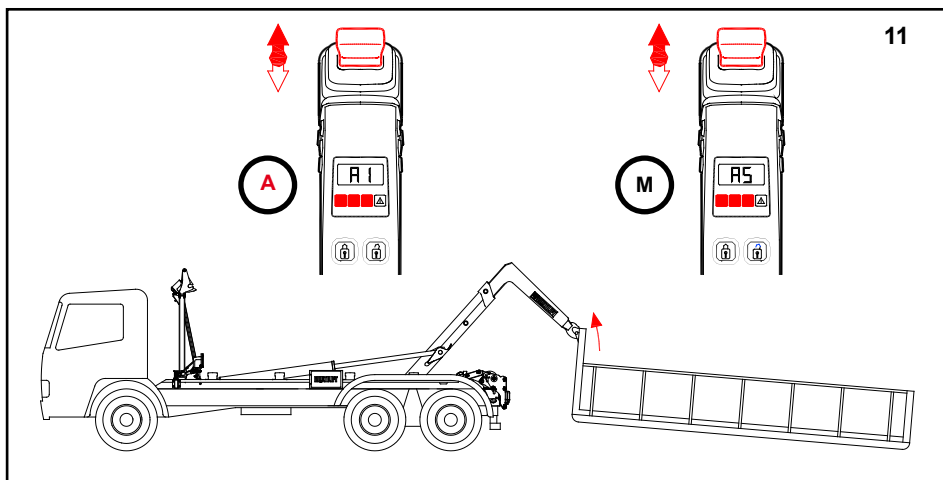
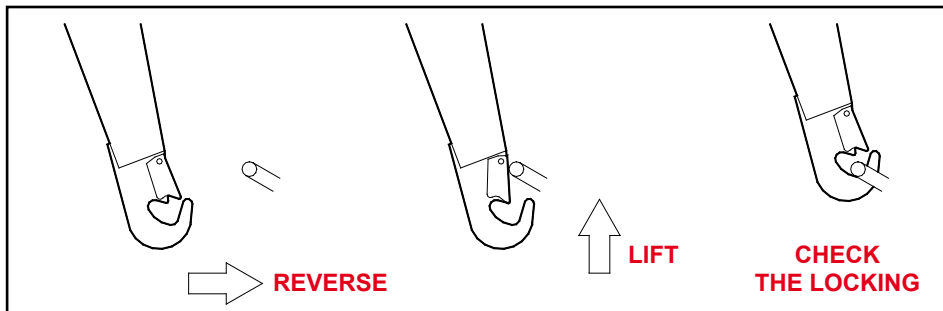

A

Choose automatic mode A1

- push the A1 button for approx. 2 s.

11. The flatrack/body comes free from the ground

- move the control lever slowly forward
- signal lights "locks not closed", "URB in" and "frame not down" on the control unit are lit
- main cylinder piston rods move inwards.

Safety lock of the gripping hook gives way to the gripping bar pushing into the hook.

- release the control lever when the hook starts to lift the flatrack/body.

Make sure that the gripping bar is properly inside the lifting hook and the safety lock is engaged.

M

Select manual mode A5

- push the A5 button for approx. 2 s.

11. Lifting the flatrack/body from the ground

- move the control lever forward (main cylinders in)
- signal lights "locks not closed", "URB in" and "frame not down" on the control unit are lit
- the main cylinder piston rods move inwards.

Safety lock of the gripping hook gives way to the gripping bar pushing into the hook.

- release the control lever when the hook starts to lift the flatrack/body.

Make sure that the gripping bar is properly inside the lifting hook and the safety lock is engaged.

CXXX / dXXX

Safety codes

>>>>>>

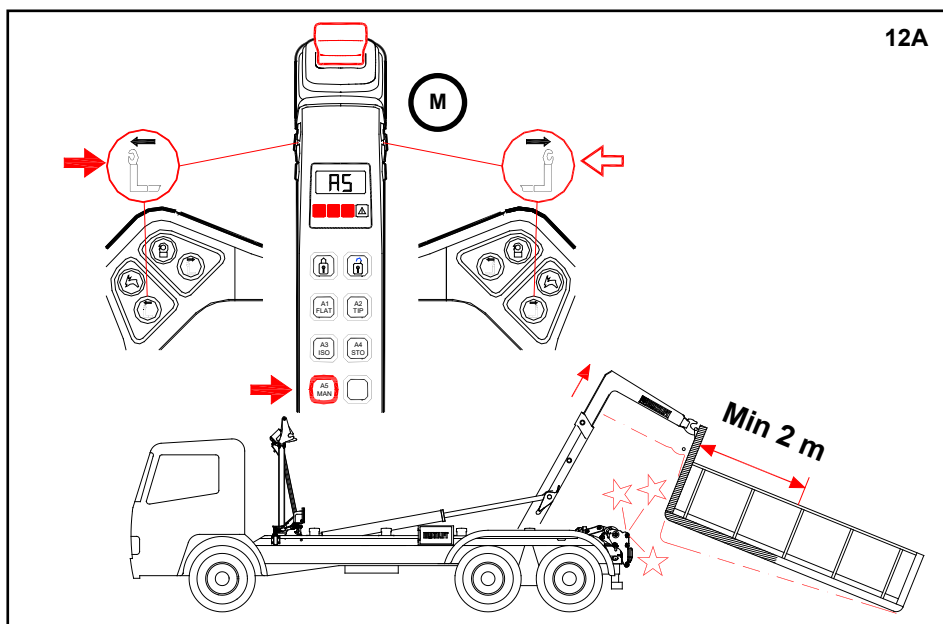
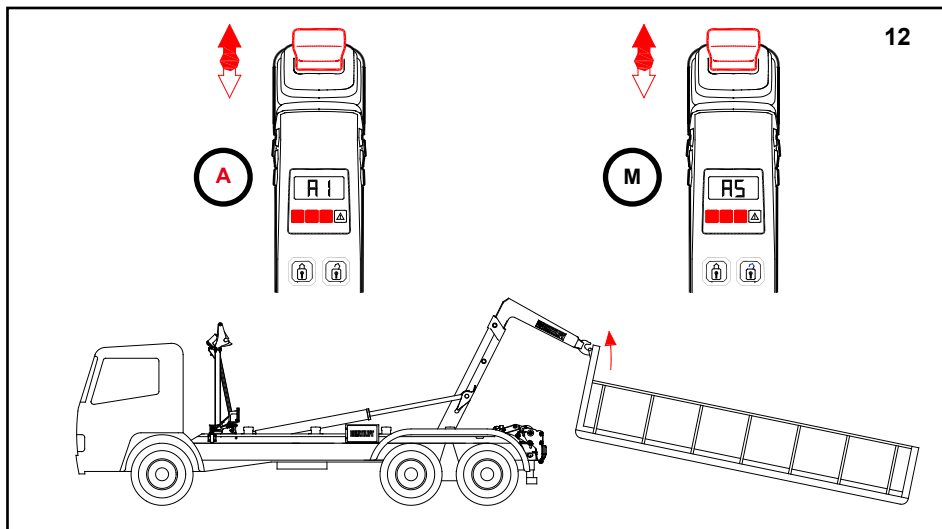

A

12. **Middle frame forward (beginning of the movement)**
- move the control lever forward
 - the main cylinder piston rods move inwards.

M

12. **Middle frame forward (beginning of the movement)**
- move the control lever forward
 - the main cylinder piston rods move inwards.

A short flatrack/body may accidentally collide with the rear rollers during loading. The darkened part of the flatrack/body in the picture should not come in contact with the rear rollers of the rear beam. The situation can be prevented by lifting the flatrack/body with horizontal movement.

Note! Horizontal movement during loading can only be done in manual mode A5.

M

- 12A. **Horizontal movement during loading** (only in manual mode A5).

Select manual mode A5

- push the A5 button for approx. 2 s.

Drive the telescope cylinder out

- by pushing the front button in the bottom row on the either side of the control unit
- release the button when the front of the flatrack/body has visibly risen above the rear rollers.

Continue the movement of phase 12 in phase 13 after raising the flatrack/body.

CXXX / dXXX

Safety codes

>>>>

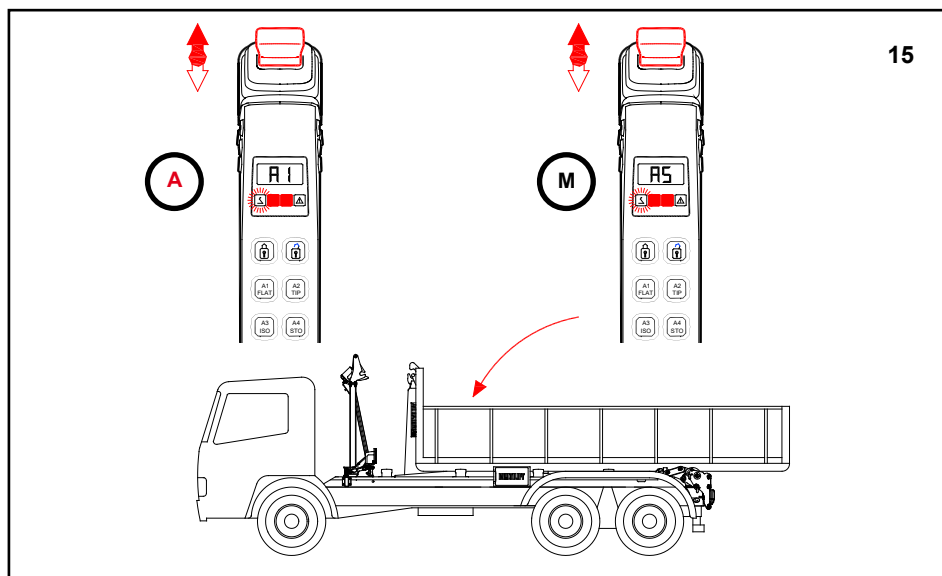
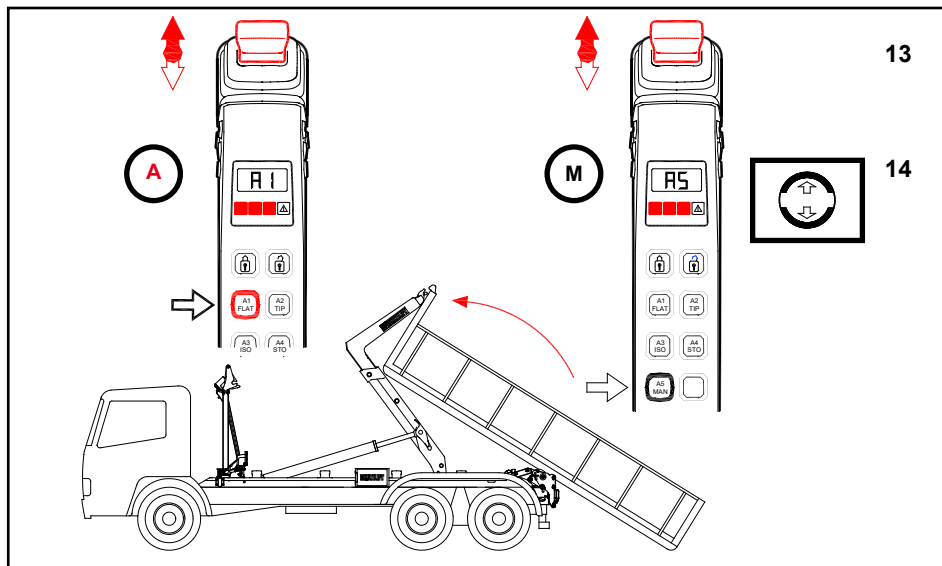

A

AUTOMATIC MODE

***If you performed phase 12A,
please choose automatic mode A1***

- *push the A1 button for approx. 2 s.*

13. Middle frame forward

- *move the control lever forward*
- *the main cylinder piston rods move inwards.*

Make sure that the flatrack/body is lifted in line with the rear rollers. Steering the truck will ensure simultaneous contact between the flatrack/body and both rear rollers.

14. Activate the handbrake when the rear end of the flatrack/body is lifted from the ground.

15. Middle frame forward (end of the movement)

- *keep the control lever in front*
- *main cylinder piston rods move inwards.*
- *“frame not down” signal light on the control unit goes out, when the middle frame comes down.*

The speed of lowering the flatrack/body must be reduced by lowering the engine speed in the last phase of the main cylinder movement.

M

MANUAL MODE

Continue in manual mode A5.

13. Middle frame forward

- *move the control lever forward*
- *the main cylinder piston rods move inwards.*

Make sure that the flatrack/body is lifted in line with the rear rollers. Steering the truck will ensure simultaneous contact between the flatrack/body and both rear rollers.

14. Activate the handbrake when the rear end of the flatrack/body is lifted from the ground.

M

15. Middle frame forward (end of the movement)

- *keep the control lever in front*
- *main cylinder piston rods move inwards*
- *“frame not down” signal light on the control unit goes out, when the middle frame comes down.*

The speed of lowering the flatrack/body must be reduced by lowering the engine speed in the last phase of the main cylinder movement.

CXXX / dXXX

Safety codes

>>>>

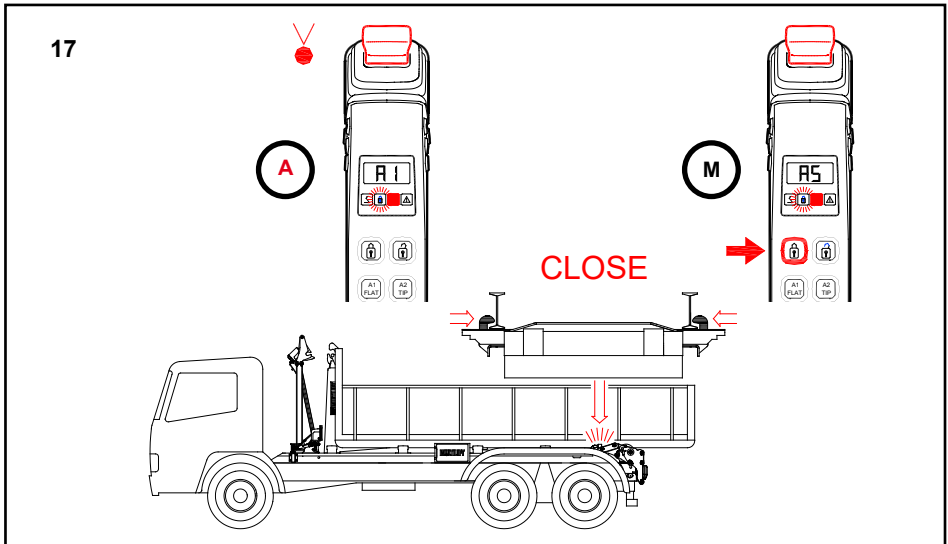
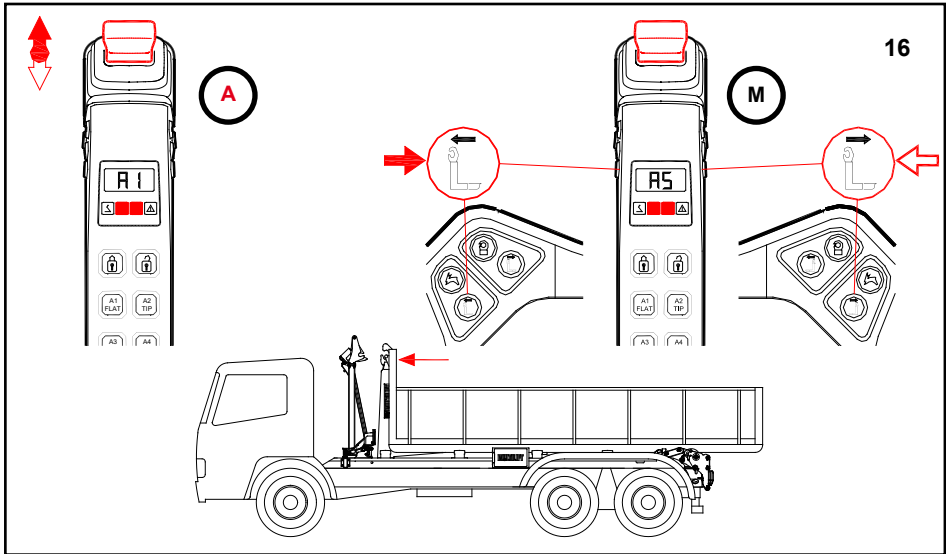

A

The main cylinders are released (floating) when the flatrack/body is about 60 mm above the body supports, and the final stage of unloading is dampened.

16. **Horizontal movement forward**
- keep the control lever in the front (telescope cylinder out).

Release the switch when the flatrack/body is in the right place (short ones) or the system has stopped the horizontal movement.

Make sure the rear end of the flatrack/body never comes over the rear rollers.

17. **Closing body locks**
- body locks close when the control lever is released
 - the "locks not closed" signal light on the control unit goes out

M

The main cylinders are released (floating) when the flatrack/body is about 60 mm above the body supports, and the final stage of unloading is dampened.

16. **Horizontal movement forward**
- by pushing the front button in the bottom row on the either side of the control unit (telescope cylinder out)

Release the button when the flatrack/body is in the right place (short ones) or the horizontal movement has reached the flatrack/body home position (approx. 350 mm from the stow/unstow position of horizontal movement).

Make sure the rear end of the flatrack/body never comes over the rear rollers.

M

17. **Closing body locks**
- close the body locks by pressing the "bodylocks close" button
 - the signal light "locks not closed" should go out.

18. **Shut off the oil supply of the hydraulic pump.**

19. **Check that all signal lights of the control unit have gone out.**

CXXX / dXXX

Safety codes

>>>

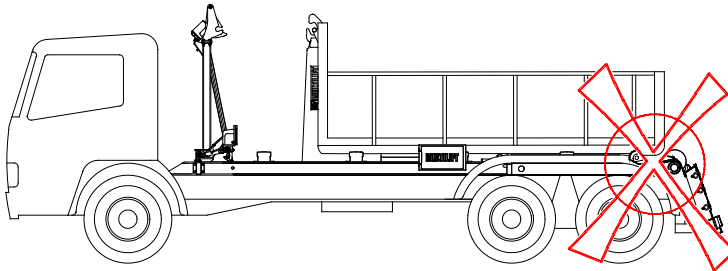
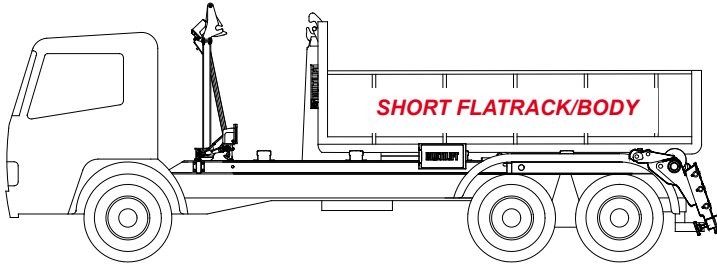

Loading a short flatrack/body

The smallest usable flatrack/body length: **XR21S56 = 4,6 m and XR21S59 = 4,9 m.**

A short flatrack/body is loaded in the same way as a regular size flatrack/body, except that the movement of the horizontal movement is left out.

Close the locks after the flatrack/body has been lowered on to the body supports.



NOTE!

**DO NOT DRIVE THE FLATRACK/BODY OVER AND
IN FRONT OF THE REAR ROLLERS!**

SAFETY CODES BY LOADING THE CONTAINER

Possible safety codes in the display when starting the loading function

Sensor location, see "XR S SENSORS" in the service chapter

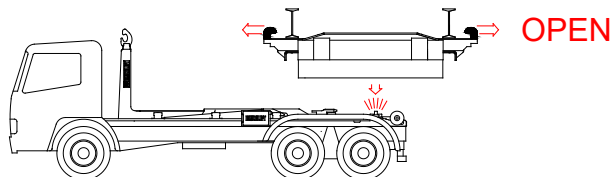

SAFETY CODE	DESCRIPTION	NOTE
C007, d012	REAR FRAME DOWN SENSOR (318) IS NOT ACTIVE. CHECK THE SENSOR AND CABLE.	LOCKS CAN BE OPENED.
C008	MIDDLE FRAME NEARLY DOWN SENSOR (120) IS NOT ACTIVE AND MIDDLE FRAME DOWN SENSOR (119) IS ACTIVE. CHECK THE SENSOR 120 AND THE CABLE.	LOCKS CAN BE OPENED.
C009	BODY LOCKS OPEN SENSOR (316) AND BODY LOCKS CLOSED SENSOR (317) ARE BOTH ACTIVE. CHECK WHY SENSOR 317 IS ACTIVE.	LOCKS CAN BE OPENED.

Possible safety codes in the display when moving the hook arm backwards

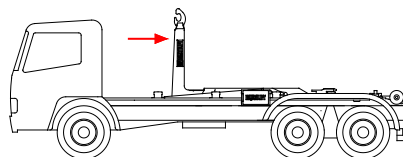

SAFETY CODE	DESCRIPTION	NOTE
C007, d012	REAR FRAME DOWN SENSOR (318) IS NOT ACTIVE. CHECK THE SENSOR AND CABLE.	HOOK ARM IS NOT MOVING.
C009, d001	BODY LOCKS OPEN SENSOR (316) AND BODY LOCKS CLOSED SENSOR (317) ARE BOTH ACTIVE. CHECK WHY SENSOR 317 IS ACTIVE.	HOOK ARM IS MOVING.
d015	TIPPING LOCK CLOSED SENSOR (319) AND HOOK ARM BACK SENSOR (320) ARE BOTH ACTIVE. CHECK SENSOR 319 AND CABLE.	HOOK ARM IS NOT MOVING.
d021	URB OUT SENSOR (323) IS ACTIVE. CHECK THE SENSOR AND CABLE.	HOOK ARM IS NOT MOVING.
d022	URB IN SENSOR (322) AND URB OUT SENSOR (323) ARE NOT ACTIVE. CHECK SENSOR 322 AND CABLE.	HOOK ARM IS NOT MOVING.

Possible safety codes in the display when moving the main cylinders out

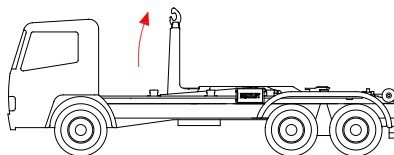

SAFETY CODE	DESCRIPTION	NOTE
C007, d012	<i>REAR FRAME DOWN</i> SENSOR (318) IS NOT ACTIVE. CHECK THE SENSOR AND CABLE.	MAIN CYLINDERS NOT MOVING OUT.
C009, d003, d015	<i>BODY LOCKS OPEN</i> SENSOR (316) AND <i>BODY LOCKS CLOSED</i> SENSOR (317) ARE BOTH ACTIVE. CHECK WHY SENSOR 317 IS ACTIVE.	MAIN CYLINDERS ARE MOVING OUT.
d003, d015	<i>BODY LOCKS OPEN</i> SENSOR (316) AND <i>BODY LOCKS CLOSED</i> SENSOR (317) ARE NOT ACTIVE. CHECK WHY SENSOR 316 IS NOT ACTIVE.	MAIN CYLINDERS NOT MOVING OUT.
d021	<i>URB OUT</i> SENSOR (323) IS ACTIVE. CHECK THE SENSOR AND CABLE.	MAIN CYLINDERS NOT MOVING OUT.
d022	<i>URB IN</i> SENSOR (322) AND <i>URB OUT</i> SENSOR (323) ARE NOT ACTIVE. CHECK SENSOR 322 AND CABLE.	MAIN CYLINDERS NOT MOVING OUT.

Possible safety codes in the display when moving the main cylinders out (middle frame up)

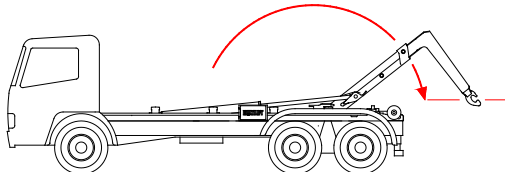

SAFETY CODE	DESCRIPTION	NOTE
C009, d003, d015	<i>BODY LOCKS CLOSED</i> SENSOR (317) IS ACTIVE. CHECK THE SENSOR AND CABLE.	MAIN CYLINDERS ARE MOVING OUT.
d003, d015	<i>BODY LOCKS OPEN</i> SENSOR (316) IS NOT ACTIVE. CHECK THE SENSOR AND CABLE.	MAIN CYLINDERS ARE MOVING OUT.
d012	<i>REAR FRAME DOWN</i> SENSOR (318) IS NOT ACTIVE. CHECK THE SENSOR AND CABLE.	MAIN CYLINDERS NOT MOVING OUT.
d021	<i>URB IN</i> SENSOR (322) AND <i>URB OUT</i> SENSOR (323) ARE BOTH ACTIVE. CHECK WHY SENSOR 323 IS ACTIVE.	MAIN CYLINDERS ARE MOVING OUT.
d021	<i>URB OUT</i> SENSOR (323) IS ACTIVE. OPERATE URB IN.	MAIN CYLINDERS NOT MOVING OUT.
d022	<i>URB IN</i> SENSOR (322) AND <i>URB OUT</i> SENSOR (323) ARE NOT ACTIVE. CHECK SENSOR 322 AND CABLE.	MAIN CYLINDERS NOT MOVING OUT.

Possible safety codes in the display when moving main cylinders in

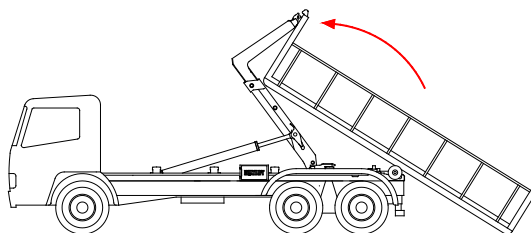

SAFETY CODE	DESCRIPTION	NOTE
d002, d003, d015	BODY LOCKS OPEN SENSOR (316) IS NOT ACTIVE. CHECK THE SENSOR AND CABLE.	MAIN CYLINDERS ARE MOVING IN.
C009, d003, d015	BODY LOCKS CLOSED SENSOR (317) IS ACTIVE. CHECK THE SENSOR AND CABLE.	MAIN CYLINDERS ARE MOVING IN.
d012	REAR FRAME DOWN SENSOR (318) IS NOT ACTIVE. CHECK THE SENSOR AND CABLE.	MAIN CYLINDERS ARE MOVING IN.

Possible safety codes in the display when moving hook arm front

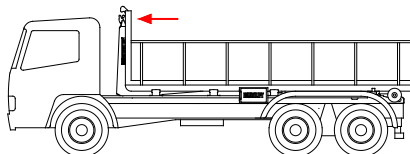

SAFETY CODE	DESCRIPTION	NOTE
C007, d012	REAR FRAME DOWN SENSOR (318) IS NOT ACTIVE. CHECK THE SENSOR AND CABLE.	HOOK ARM IS NOT MOVING FRONT.
C008	MIDDLE FRAME NEARLY DOWN SENSOR (120) IS NOT ACTIVE. CHECK THE SENSOR AND CABLE.	HOOK ARM IS MOVING FRONT.
C009, d001	BODY LOCKS OPEN SENSOR (316) AND BODY LOCKS CLOSED SENSOR (317) ARE BOTH ACTIVE. CHECK WHY SENSOR 317 IS ACTIVE.	HOOK ARM IS MOVING FRONT.
d001	BODY LOCKS OPEN SENSOR (316) IS NOT ACTIVE. CHECK THE SENSOR AND CABLE.	HOOK ARM IS NOT MOVING FRONT.
d016	PULL LIMITER SENSOR (321) IS ACTIVE. THE CONTAINER IS IN MECHANICAL LOCKS.	HOOK ARM IS NOT MOVING FRONT.

Possible safety codes in the display when closing the locks

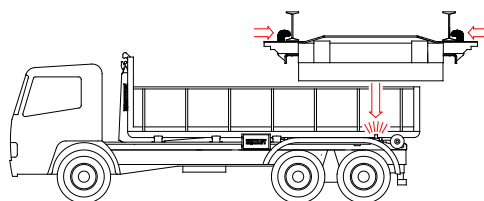

CLOSE

SAFETY CODE	DESCRIPTION	NOTE
C007, d012	REAR FRAME DOWN SENSOR (318) IS NOT ACTIVE. CHECK THE SENSOR AND CABLE.	LOCKS CAN BE CLOSED.
C008	MIDDLE FRAME NEARLY DOWN SENSOR (120) IS NOT ACTIVE. CHECK THE SENSOR AND CABLE.	LOCKS CAN BE CLOSED.
C009	BODY LOCKS OPEN SENSOR (316) AND BODY LOCKS CLOSED SENSOR (317) ARE BOTH ACTIVE. CHECK THE SENSORS AND CABLE.	LOCKS CAN BE CLOSED.

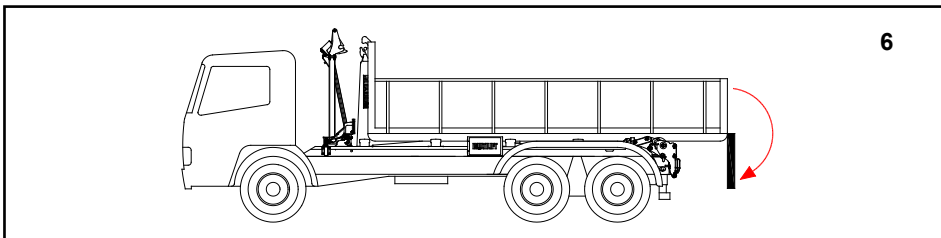
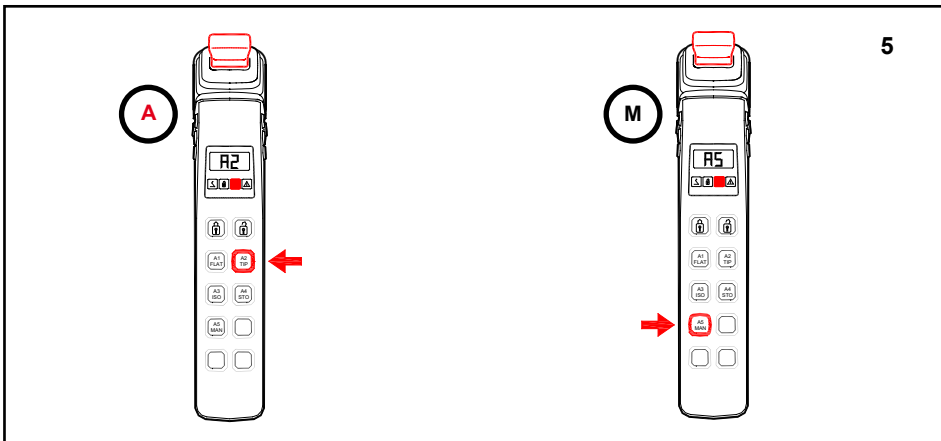

Tipping a flatrack/body

XR21S -EQUIPMENT IN TRANSPORT POSITION, STARTING MOVEMENTS

1. See the safety instructions before tipping.

THE XR21S SHOULD NEVER BE USED TO TIP AN ISO CONTAINER

2. Drive the truck to the place where the load has to be discharged.
3. Engage the parking brake.
4. Engage the hydraulic pump.

AUTOMATIC MODE A2

A

5. **Select automatic mode A2**
- push the A2 button approx 2 s.

MANUAL MODE A5

M

5. **Choose manual mode A5**
- push the A5 button for approx. 2 s.

6. **Open the flatrack/body tail gate**
- note the flatrack/body operating instructions
- stand by the side of the flatrack/body so that the opening tail gate and discharging load do not hit you.

CXXX / dXXX

Safety codes

>>>>

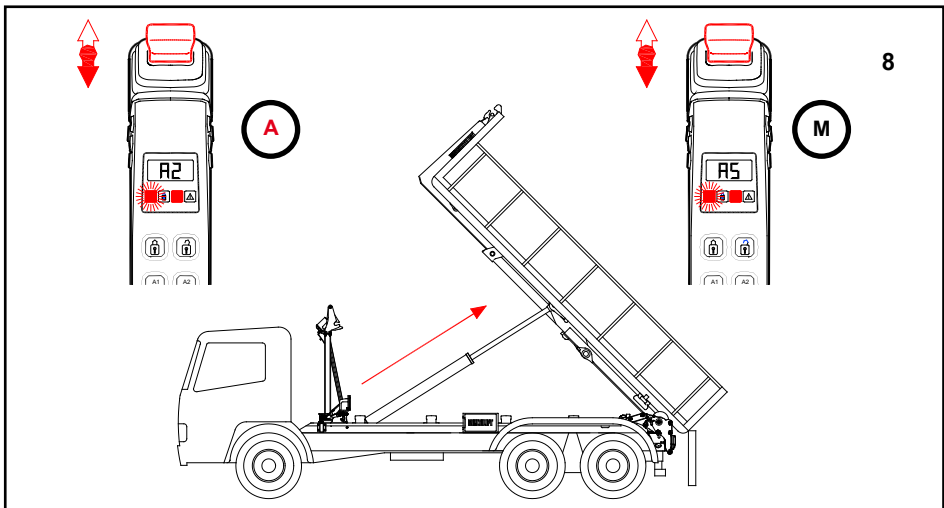
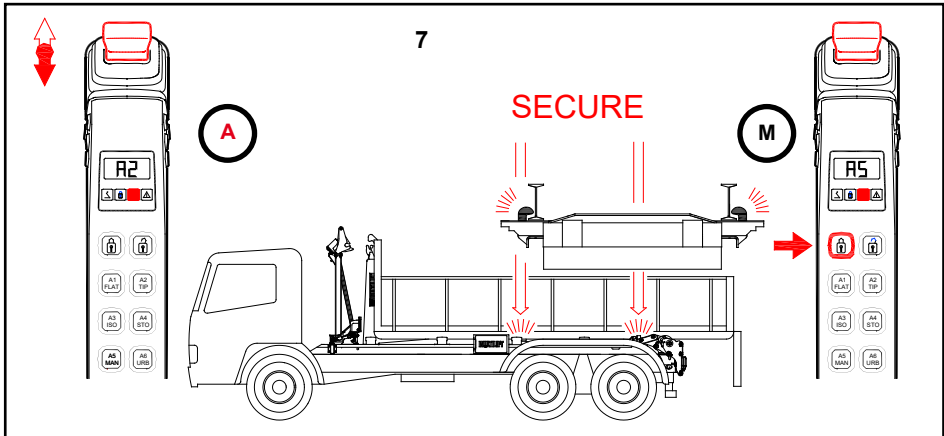

A

7. **Checking body locks**
- move the control lever slowly backwards
 - under-run bar is retracted, if it is not in
 - URB signal light on the control unit is lit, when the under-run bar is fully in the in position
 - the system will close the body locks, if they are open
 - "locks not closed" signal light should not be lit
 - the middle/rear frame (= tipping lock) must be closed.

8. **Raise the tipping device (middle frame together with the rear frame) into the desired or the maximum tipping angle**
- keep the control lever back
 - make sure the flatrack/body doesn't hit the rear bumper or the ground
 - "frame not down" signal light is lit, when the middle frame is lifted off the sub frame
 - stop the movement by releasing the control lever.

M

7. **Check that the body locks are engaged**
- the hydraulic locks are engaged
 - check that the body locks are engaged by pressing the "bodylocks closed" button for approx. 2 seconds before starting the tipping movement
 - the body lock signal light should not be lit
 - the middle/rear frame (= tipping lock) must be closed
 - under-run bar is retracted, if it is not in
 - URB signal light on the control unit is lit, when the under-run bar is fully in the in position.

M

8. **Raise the tipping device (middle frame together with the rear frame) into the desired or the maximum tipping angle**
- move the control lever slowly backwards
 - make sure the flatrack/body doesn't hit the rear bumper or the ground
 - "frame not down" signal light is lit, when the middle frame is lifted off the sub frame
 - stop the movement by releasing the control lever.

CXXX / dXXX

Safety codes

>>>

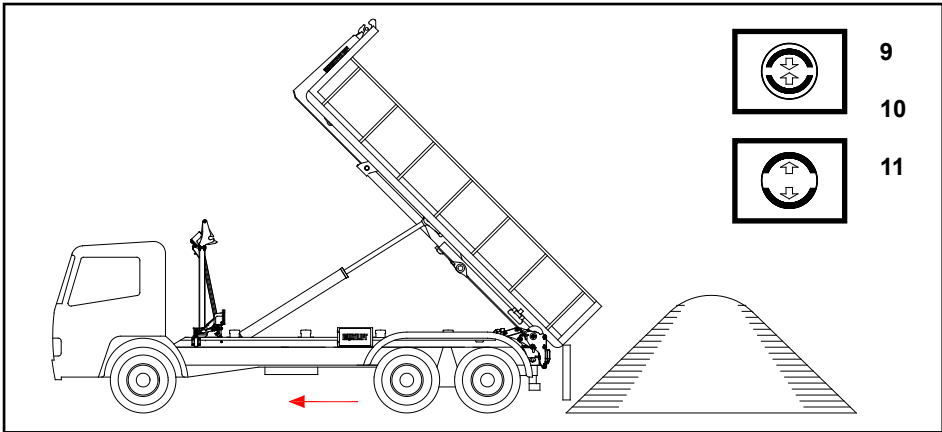

A

9. *Decrease the speed of tipping movement to prevent an abrupt stop during the last tipping phase.*

M

9. Decrease the speed of tipping movement to prevent an abrupt stop during the last tipping phase.

10. Release the parking brake and drive, if needed, a little forward in order to empty the complete contents of the flatrack/body.
- the PTO can be engaged during this phase.
11. Engage the parking brake.

CXXX / dXXX

Safety codes

>>

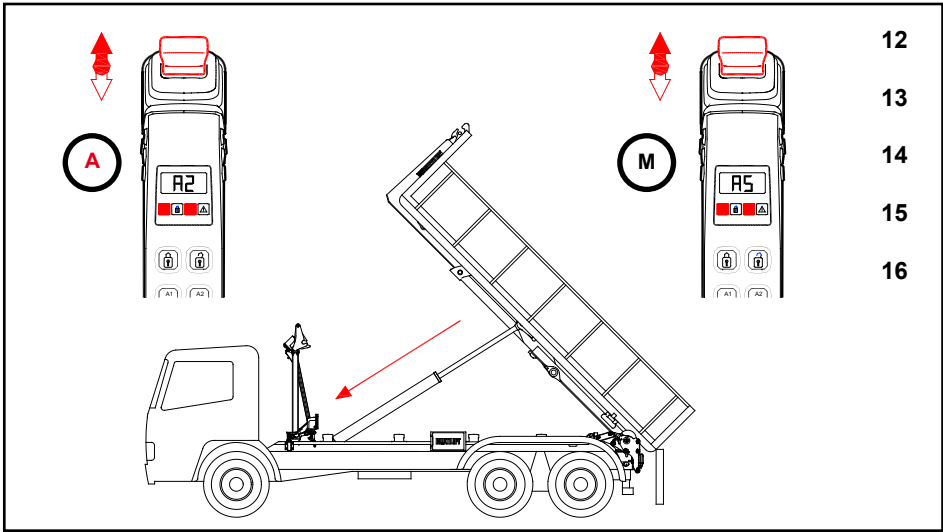

Lowering the tipping device

AUTOMATIC MODE A2

A

12. **Lower the tipping arm (middle frame together with the rear frame)**
 - move the control lever forward
 - stop the movement by releasing the control lever.

MANUAL MODE A5

M

12. **Lower the tipping arm (middle frame together with the rear frame)**
 - move the control lever forward
 - stop the movement by releasing the control lever.

The main cylinders are released (floating) when the flatrack/body is about 60 mm above the body supports, and the final stage of unloading is dampened.

13. **Check that the frame of the XR21S equipment and the flatrack/body are in the lowest position.**
14. **Close the flatrack/body tail gate.**
15. **Shut off the oil supply of the hydraulic pump.**
16. **Check that all signal lights of the control unit have gone out.**

CXXX / dXXX

Safety codes

>

SAFETY CODES BY TIPPING THE CONTAINER

Possible safety codes in the display when starting the tipping function

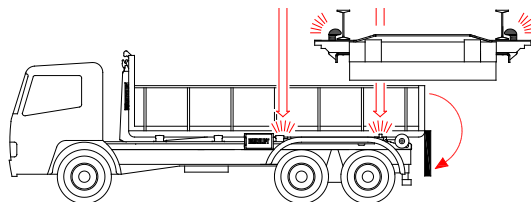

SECURE

SAFETY CODE	DESCRIPTION	NOTE
C007, d012	MIDDLE FRAME DOWN SENSOR (119) IS ACTIVE, BUT REAR FRAME DOWN SENSOR (318) IS NOT ACTIVE. CHECK THE SENSOR AND CABLE.	TIPPING IS WORKABLE.
C008	MIDDLE FRAME NEARLY DOWN SENSOR (120) IS NOT ACTIVE AND REAR FRAME DOWN SENSOR (318) IS ACTIVE. CHECK THE SENSOR 120 AND THE CABLE.	TIPPING IS WORKABLE.
C009, d000, d004	BODY LOCKS OPEN SENSOR (316) AND BODY LOCKS CLOSED SENSOR (317) ARE BOTH ACTIVE. CHECK WHY SENSOR 316 IS ACTIVE.	TIPPING IS WORKABLE.
d003	TIPPING LOCK CLOSED SENSOR (319) HAS LOST SIGNAL. CHECK THAT TIPPING LOCK IS CLOSED AND SENSOR ACTIVE.	TIPPING IS PREVENTED.
d004	BODY LOCKS CLOSED SENSOR (317) IS NOT ACTIVE.	TIPPING IS PREVENTED.
d015	HOOK ARM BACK SENSOR (320) IS ACTIVE. CHECK THE SENSOR AND CABLE.	TIPPING IS PREVENTED.
d021	URB OUT SENSOR (323) IS ACTIVE OR URB IN SENSOR (322) AND URB OUT SENSOR (323) ARE BOTH ACTIVE.	TIPPING IS PREVENTED. TIPPING IS WORKABLE.
d022	URB IN SENSOR (322) AND URB OUT SENSOR (323) ARE NOT ACTIVE.	TIPPING IS WORKABLE.

Possible safety codes in the display when tipping up

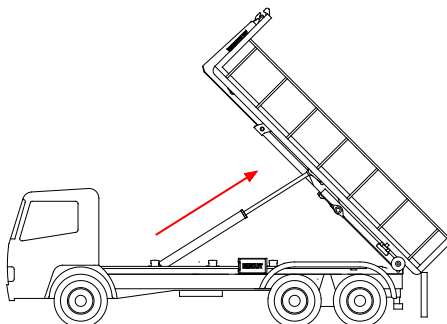

SAFETY CODE	DESCRIPTION	NOTE
C007, C008	MIDDLE FRAME DOWN SENSOR (119) IS ACTIVE, BUT REAR FRAME DOWN SENSOR (318) IS NOT ACTIVE. CHECK THE SENSOR 119 AND THE CABLE.	TIPPING IS WORKABLE.
C009, d012	BODY LOCKS OPEN SENSOR (316) AND BODY LOCKS CLOSED SENSOR (317) ARE BOTH ACTIVE. CHECK WHY SENSOR 316 IS ACTIVE.	TIPPING IS WORKABLE.
d012	BODY LOCKS CLOSED SENSOR (317) IS NOT ACTIVE. CHECK WHY THE SENSOR IS NOT ACTIVE.	TIPPING IS WORKABLE.
d003, d012	TIPPING LOCK CLOSED SENSOR (319) HAS LOST SIGNAL. CHECK THE SENSOR 119 AND THE CABLE.	TIPPING IS PREVENTED.
d015	HOOK ARM BACK SENSOR (320) IS ACTIVE. CHECK THE SENSOR AND CABLE.	TIPPING IS PREVENTED.
d021	URB OUT SENSOR (323) IS ACTIVE. CHECK THE SENSOR.	TIPPING IS PREVENTED.
d022	URB IN SENSOR (322) IS ACTIVE. CHECK THE SENSOR.	TIPPING IS PREVENTED.

Possible safety codes in the display when lowering down

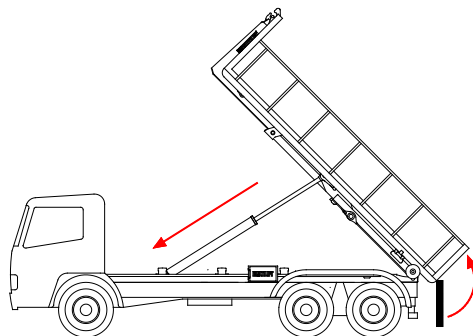

SAFETY CODE	DESCRIPTION	NOTE
C009, d012	BODY LOCKS OPEN SENSOR (316) AND BODY LOCKS CLOSED SENSOR (317) ARE BOTH ACTIVE. CHECK WHY SENSOR 316 IS ACTIVE.	LOWERING IS WORKABLE.
d012	BODY LOCKS CLOSED SENSOR (317) IS NOT ACTIVE. CHECK WHY THE SENSOR IS NOT ACTIVE.	LOWERING IS WORKABLE.
d012	TIPPING LOCK CLOSED SENSOR (319) HAS LOST SIGNAL. CHECK THE SENSOR AND CABLE.	LOWERING IS WORKABLE.
d015	HOOK ARM BACK SENSOR (320) IS ACTIVE. CHECK THE SENSOR AND CABLE.	LOWERING IS WORKABLE.

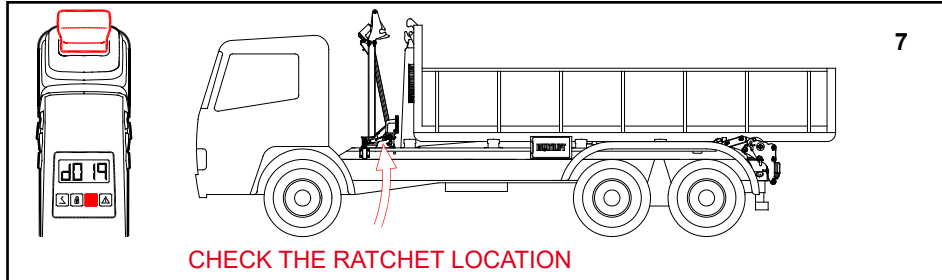
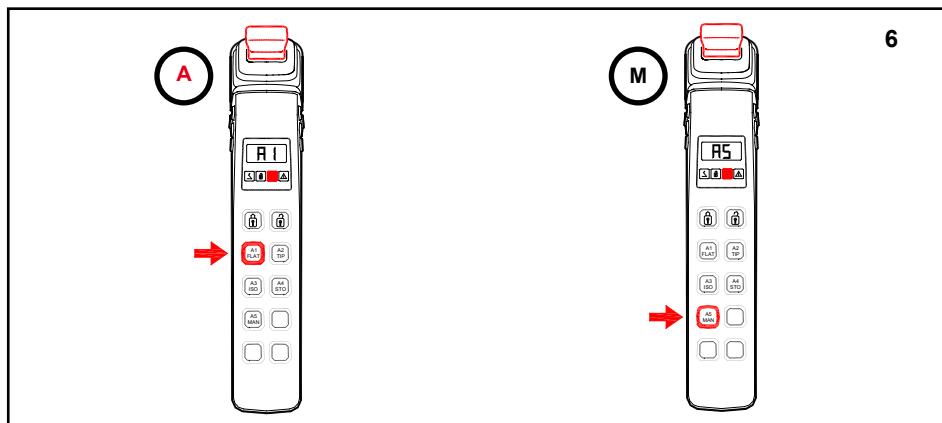
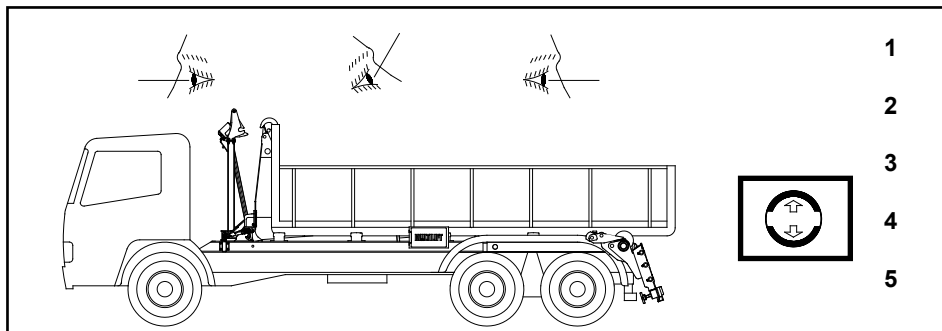

Unloading a flatrack/body

XR21S -EQUIPMENT IN TRANSPORT POSITION, STARTING MOVEMENTS

1. See the safety instructions before unloading.
2. Drive the truck to the place where the flatrack/body has to be unloaded.
3. Check the working area
- ensure that there is enough space in front, rear and above the truck.
4. Engage the parking brake.
5. Engage the hydraulic pump.

AUTOMATIC MODE A1

MANUAL MODE A5

- A**
6. Choose automatic mode A1
- push the A1 button for approx. 2 s.

- M**
6. Choose manual mode A5
- push the A5 button for approx. 2 s.

7. If it seems impossible to select the mode and code "d019" is displayed on the control unit, make sure that the attachment joints of the liftframe ratchets are attached to the stowage.

CXXX / dXXX

Safety codes

>>>>

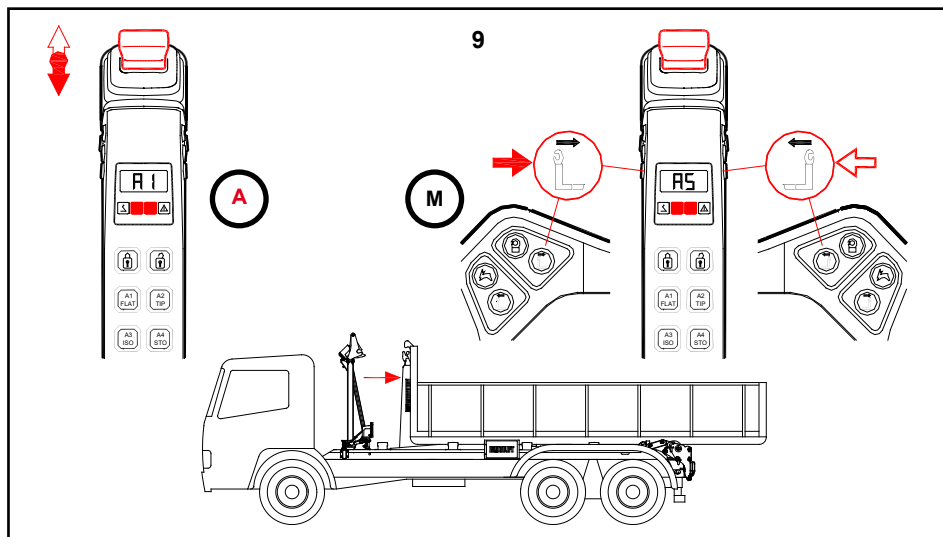
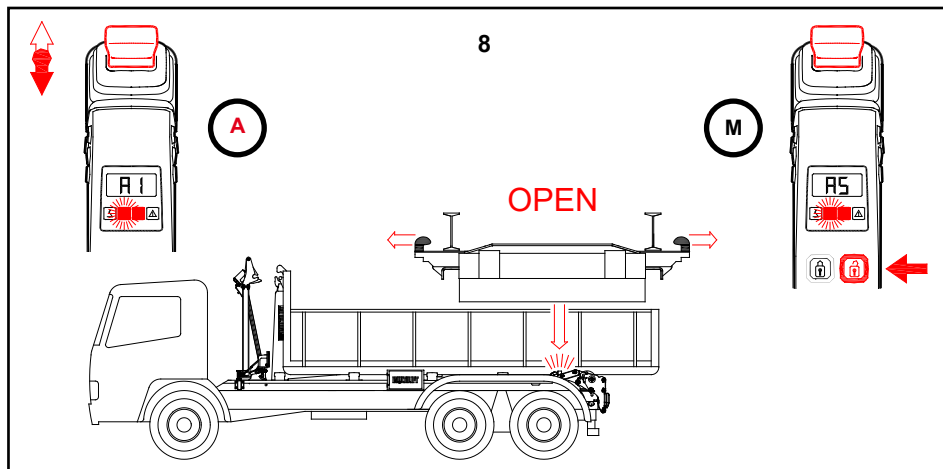

A

8. Opening the body and tipping locks

- move the control lever slowly backwards
- under-run bar is retracted, if it is not in
- URB signal light on the control unit is lit, when the under-run bar is fully in the in position
- body locks will open
- when the locks are open, the "locks not closed" signal light on the control unit is lit.

9. Horizontal movement into rear position

- keep the control lever in rear position
- horizontal movement slides backwards (cylinder in)
- mechanical tipping lock opens when the hook frame is in rear position.

M

8. Open the body locks

- push the "bodylocks open" button
- under-run bar is retracted, if it is not in
- URB signal light on the control unit is lit, when the under-run bar is fully in the in position
- when the locks are open, the "locks not closed" signal light on the control unit is lit.

M

9. Drive the horizontal movement into rear position

- push the rearmost button in the bottom row on the either side of the control unit
- horizontal movement slides backwards (cylinder in)
- mechanical tipping lock opens when the hook frame is in rear position.

CXXX / dXXX

Safety codes

>>>>

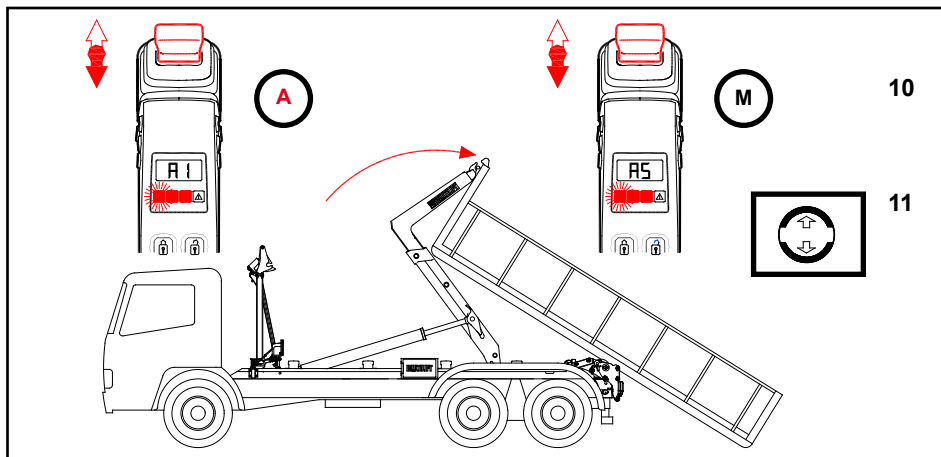

NOTE! In some cases the flatrack/body will push the truck forward.
Assist this, if necessary, by steering the truck and simultaneously holding the control lever in backward position.

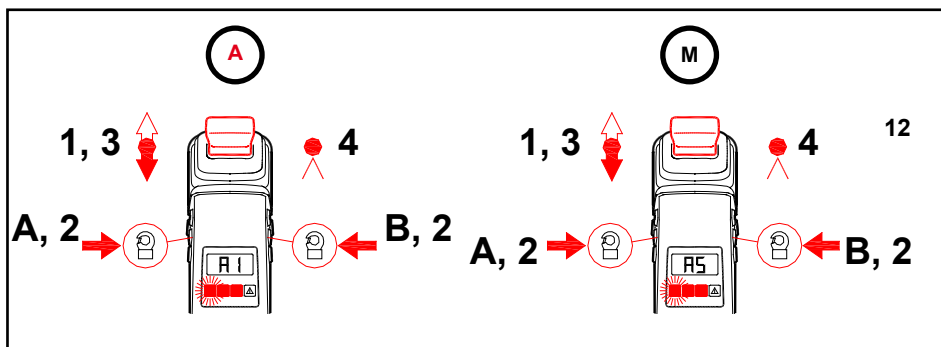

CXXX / dXXX

Safety codes

>>>

A

10. Middle frame back

- keep the control lever in rear position. (main cylinders out).
- "frame not down" signal light is lit, when the middle frame is lifted off the subframe.

M

10. Drive the middle frame back

- drive the middle frame back by moving the control lever back (main cylinders out).
- "frame not down" signal light is lit, when the middle frame is lifted off the subframe.

11. Release the parking brake when the flatrack/body rear end touches the ground.

Only in case the truck is on uphill slope, you may not release the hand brake, as in that case the truck and the flatrack/body would move backwards.

A

12. Middle frame backwards, open the safety lock of the gripping hook and release the hook from the flatrack/body gripping bar

- 1 - keep the control lever in rear position (main cylinders out).
- 2 - open the safety lock of the gripping hook by pressing button A or B on the control unit immediately before lowering the front end of the flatrack/body to the ground
- 3 - continue the downward motion of the main cylinders, with the safety lock open, until the hook is released from the gripping bar
- 4 - stop the movement by releasing the control lever.

M

12. Drive the middle frame backwards, open the safety lock of the gripping hook and release the hook from the flatrack/body gripping bar

- 1 - drive the middle frame back by keeping the control lever back (main cylinders out)
- 2 - open the safety lock of the gripping hook by pressing button A or B on the control unit immediately before lowering the front end of the flatrack/body to the ground
- 3 - continue the downward motion of the main cylinders, with the safety lock open, until the hook is released from the gripping bar
- 4 - stop the movement by releasing the control lever.

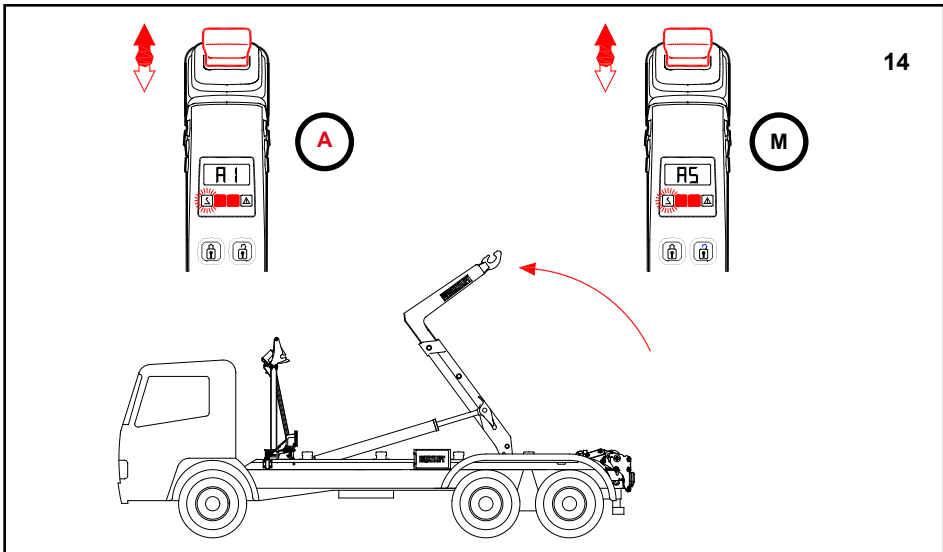
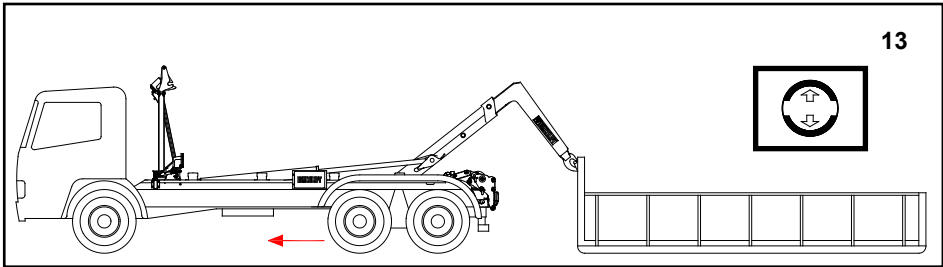

13. Drive the truck forward. Engage the parking brake.

A

Continue in automatic mode A1.

14. Middle frame forward (beginning of the movement)

- move the control lever forward
- signal lights "locks not closed", "URB in" and "frame not down" on the control unit are lit
- the main cylinder piston rods move inwards.

Drive the middle frame forward by keeping the control lever in middle position in the front.

- "frame not down" signal light on the control unit goes out, when the middle frame comes down

The main cylinders are released (floating) when the flatrack/body is about 60 mm above the body supports, and the final stage of unloading is dampened.

M

Continue in manual mode A5.

14. Middle frame forward (beginning of the movement)

- move the control lever forward (main cylinders in)
- signal lights "locks not closed", "URB in" and "frame not down" on the control unit are lit
- the main cylinder piston rods move inwards.

Drive the middle frame down, all the way onto the sub frame.

- "frame not down" signal light on the control unit goes out, when the middle frame comes down

The main cylinders are released (floating) when the flatrack/body is about 60 mm above the body supports, and the final stage of unloading is dampened.

Stop the movement when the middle frame rests on the sub frame by releasing the control lever.

CXXX / dXXX

Safety codes

>>

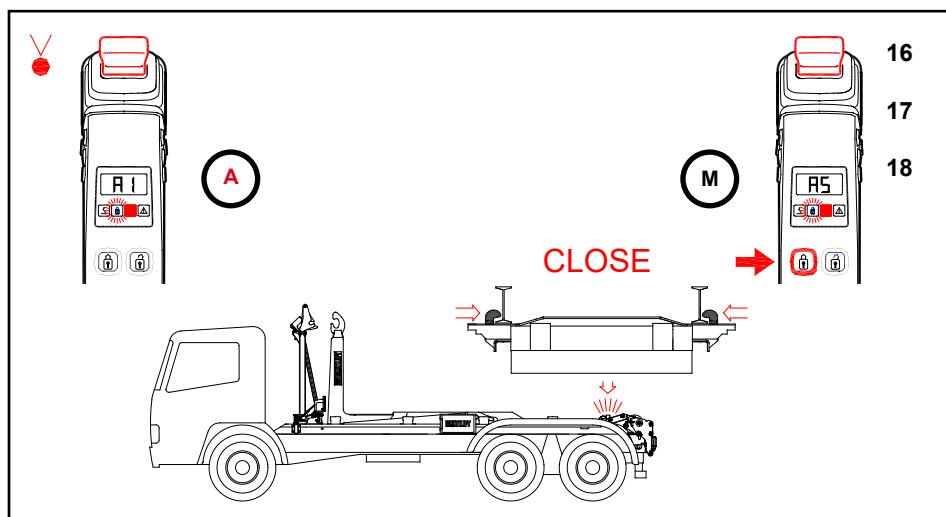
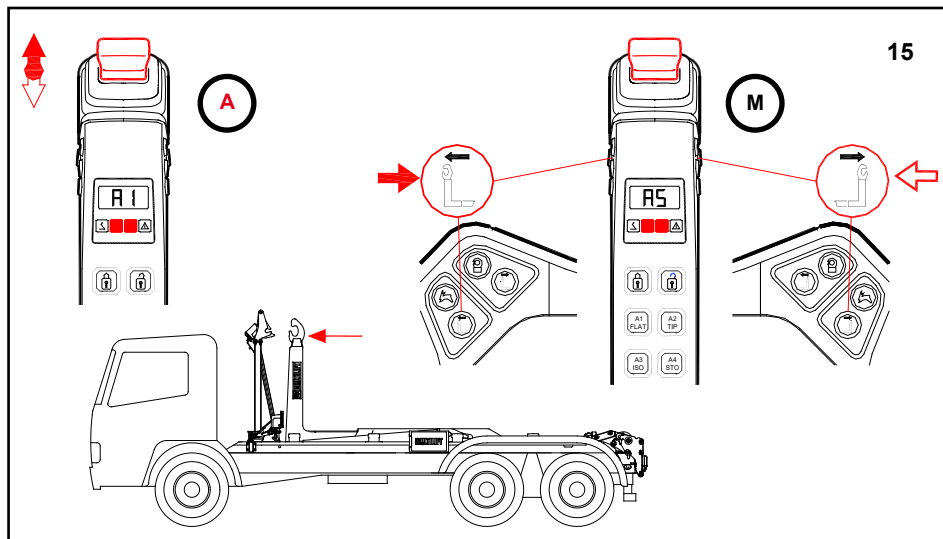

A

- 15. Horizontal movement forward**
- keep the control lever in the front (telescope cylinder in).

- 16. Closing body locks**
- body locks close when the control lever is released
- the "locks not closed" signal light on the control unit goes out.

M

- 15. Horizontal movement forward**
- by pushing the front button in the bottom row on the either side of the control unit (telescope cylinder in).
Release the button when the horizontal movement has reached the flatrack/body home position (approx. 350 mm from the stow/unstow position of horizontal movement).

M

- 16. Closing body locks**
- close the body locks by pressing the "bodylocks close" button
- the signal light "locks not closed" should go out.

Always drive in traffic with the middle frame lowered onto the sub frame.

- 17. Shut off the oil supply of the hydraulic pump.**
18. Check that all signal lights of the control unit have gone out.

CXXX / dXXX

Safety codes

>

SAFETY CODES BY UNLOADING THE CONTAINER

Possible safety codes in the display when starting the unloading function

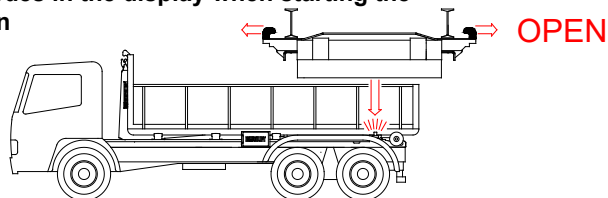

SAFETY CODE	DESCRIPTION	NOTE
C007, d012	REAR FRAME DOWN SENSOR (318) IS NOT ACTIVE. CHECK THE SENSOR AND CABLE.	LOCKS CAN BE OPENED.
C008	MIDDLE FRAME NEARLY DOWN SENSOR (120) IS NOT ACTIVE AND MIDDLE FRAME DOWN SENSOR (119) IS ACTIVE. CHECK THE SENSOR 120 AND THE CABLE.	LOCKS CAN BE OPENED.
C009	BODY LOCKS OPEN SENSOR (316) AND BODY LOCKS CLOSED SENSOR (317) ARE BOTH ACTIVE. CHECK WHY SENSOR 317 IS ACTIVE.	LOCKS CAN BE OPENED.

Possible safety codes in the display when moving the hook arm backwards

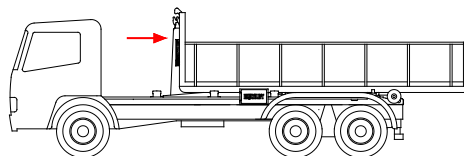

SAFETY CODE	DESCRIPTION	NOTE
C007, d012	REAR FRAME DOWN SENSOR (318) IS NOT ACTIVE. CHECK THE SENSOR AND CABLE.	HOOK ARM IS NOT MOVING.
C009, d001	BODY LOCKS OPEN SENSOR (316) AND BODY LOCKS CLOSED SENSOR (317) ARE BOTH ACTIVE. CHECK WHY SENSOR 317 IS ACTIVE.	HOOK ARM IS MOVING.
d015	TIPPING LOCK CLOSED SENSOR (319) AND HOOK ARM BACK SENSOR (320) ARE BOTH ACTIVE. CHECK SENSOR 319 AND CABLE.	HOOK ARM IS NOT MOVING.
d021	URB OUT SENSOR (323) IS ACTIVE. CHECK THE SENSOR AND CABLE.	HOOK ARM IS NOT MOVING.
d022	URB IN SENSOR (322) AND URB OUT SENSOR (323) ARE NOT ACTIVE. CHECK SENSOR 322 AND CABLE.	HOOK ARM IS NOT MOVING.

Possible safety codes in the display when moving the main cylinders out

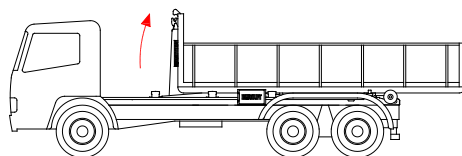

SAFETY CODE	DESCRIPTION	NOTE
C007, d012	<i>REAR FRAME DOWN</i> SENSOR (318) IS NOT ACTIVE. CHECK THE SENSOR AND CABLE.	MAIN CYLINDERS NOT MOVING OUT.
C009, d003, d015	<i>BODY LOCKS OPEN</i> SENSOR (316) AND <i>BODY LOCKS CLOSED</i> SENSOR (317) ARE BOTH ACTIVE. CHECK WHY SENSOR 317 IS ACTIVE.	MAIN CYLINDERS ARE MOVING OUT.
d003, d015	<i>BODY LOCKS OPEN</i> SENSOR (316) AND <i>BODY LOCKS CLOSED</i> SENSOR (317) ARE NOT ACTIVE. CHECK WHY SENSOR 316 IS NOT ACTIVE.	MAIN CYLINDERS NOT MOVING OUT.
d021	<i>URB OUT</i> SENSOR (323) IS ACTIVE. CHECK THE SENSOR AND CABLE.	MAIN CYLINDERS NOT MOVING OUT.
d022	<i>URB IN</i> SENSOR (322) AND <i>URB OUT</i> SENSOR (323) ARE NOT ACTIVE. CHECK SENSOR 322 AND CABLE.	MAIN CYLINDERS NOT MOVING OUT.

Possible safety codes in the display when moving the main cylinders out (middle frame up)

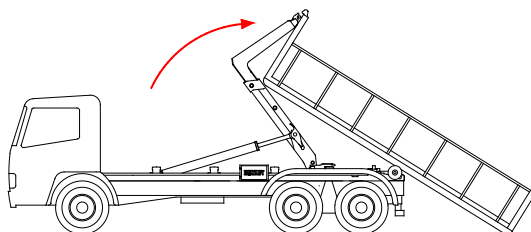

SAFETY CODE	DESCRIPTION	NOTE
C009, d003, d015	<i>BODY LOCKS CLOSED</i> SENSOR (317) IS ACTIVE. CHECK THE SENSOR AND CABLE.	MAIN CYLINDERS ARE MOVING OUT.
d003, d015	<i>BODY LOCKS OPEN</i> SENSOR (316) IS NOT ACTIVE. CHECK THE SENSOR AND CABLE.	MAIN CYLINDERS ARE MOVING OUT.
d012	<i>REAR FRAME DOWN</i> SENSOR (318) IS NOT ACTIVE. CHECK THE SENSOR AND CABLE.	MAIN CYLINDERS NOT MOVING OUT.
d021	<i>URB IN</i> SENSOR (322) AND <i>URB OUT</i> SENSOR (323) ARE BOTH ACTIVE. CHECK WHY SENSOR 323 IS ACTIVE.	MAIN CYLINDERS ARE MOVING OUT.
d021	<i>URB OUT</i> SENSOR (323) IS ACTIVE. OPERATE URB IN.	MAIN CYLINDERS NOT MOVING OUT.
d022	<i>URB IN</i> SENSOR (322) AND <i>URB OUT</i> SENSOR (323) ARE NOT ACTIVE. CHECK SENSOR 322 AND CABLE.	MAIN CYLINDERS NOT MOVING OUT.

Possible safety codes in the display when moving main cylinders in

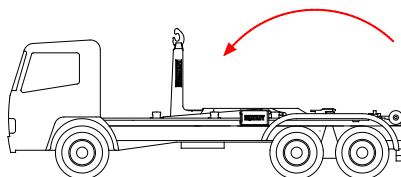

SAFETY CODE	DESCRIPTION	NOTE
d002, d003, d015	BODY LOCKS OPEN SENSOR (316) IS NOT ACTIVE. CHECK THE SENSOR AND CABLE.	MAIN CYLINDERS ARE MOVING IN.
C009, d003, d015	BODY LOCKS CLOSED SENSOR (317) IS ACTIVE. CHECK THE SENSOR AND CABLE.	MAIN CYLINDERS ARE MOVING IN.
d012	REAR FRAME DOWN SENSOR (318) IS NOT ACTIVE. CHECK THE SENSOR AND CABLE.	MAIN CYLINDERS ARE MOVING IN.

Possible safety codes in the display when moving hook arm front

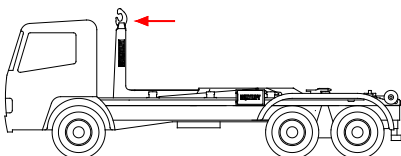

SAFETY CODE	DESCRIPTION	NOTE
C007, d012	REAR FRAME DOWN SENSOR (318) IS NOT ACTIVE. CHECK THE SENSOR AND CABLE.	HOOK ARM IS NOT MOVING FRONT.
C008	MIDDLE FRAME NEARLY DOWN SENSOR (120) IS NOT ACTIVE. CHECK THE SENSOR AND CABLE.	HOOK ARM IS MOVING FRONT.
C009, d001	BODY LOCKS OPEN SENSOR (316) AND BODY LOCKS CLOSED SENSOR (317) ARE BOTH ACTIVE. CHECK WHY SENSOR 317 IS ACTIVE.	HOOK ARM IS MOVING FRONT.
d001	BODY LOCKS OPEN SENSOR (316) IS NOT ACTIVE. CHECK THE SENSOR AND CABLE.	HOOK ARM IS NOT MOVING FRONT.
d016	PULL LIMITER SENSOR (321) IS ACTIVE. CHECK THE SENSOR AND CABLE.	HOOK ARM IS NOT MOVING FRONT.

Possible safety codes in the display when closing the locks

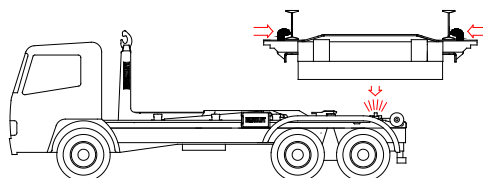

CLOSE

SAFETY CODE	DESCRIPTION	NOTE
C007, d012	<i>REAR FRAME DOWN</i> SENSOR (318) IS NOT ACTIVE. CHECK THE SENSOR AND CABLE.	LOCKS CAN BE CLOSED.
C008	<i>MIDDLE FRAME NEARLY DOWN</i> SENSOR (120) IS NOT ACTIVE. CHECK THE SENSOR AND CABLE.	LOCKS CAN BE CLOSED.
C009	<i>BODY LOCKS OPEN</i> SENSOR (316) AND <i>BODY LOCKS CLOSED</i> SENSOR (317) ARE BOTH ACTIVE. CHECK THE SENSORS AND CABLE.	LOCKS CAN BE CLOSED.

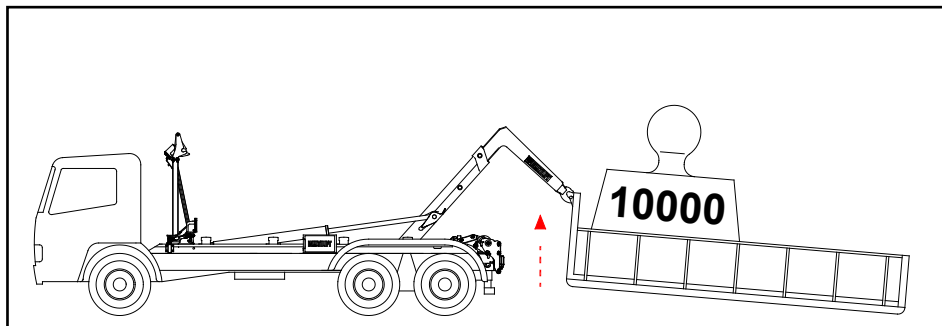
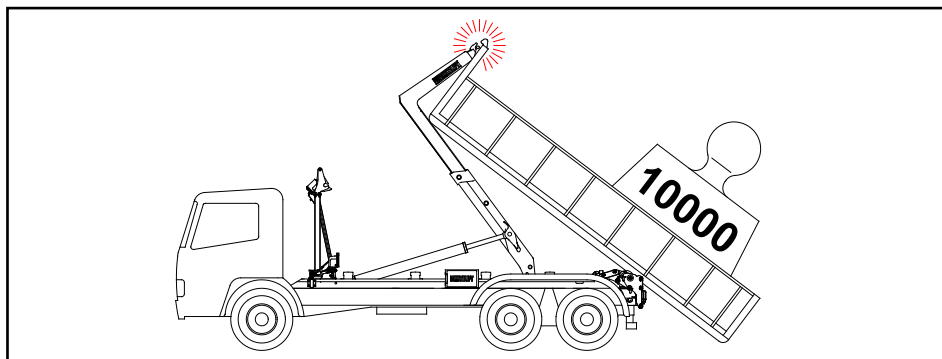
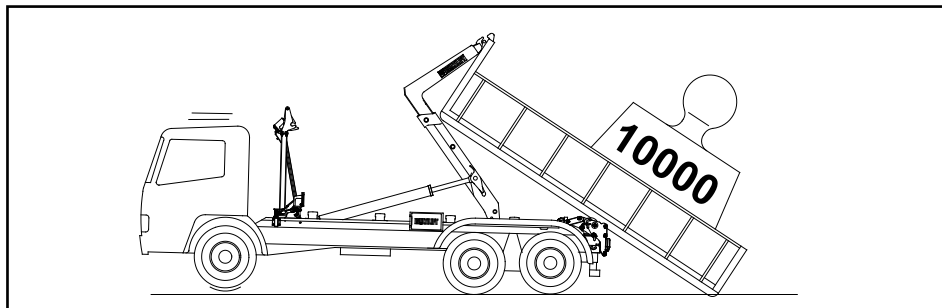

Loading of rear heavy flatrack/body

A flatrack/body loaded more heavily at the rear end can cause the truck front wheels to be lifted of the ground. Be extra cautious when this happens. When the flatrack/body is on rear rollers, move the hook arm forward before lowering the middle frame on the sub-frame. Otherwise there is a danger of the flatrack/body becoming loose from the hook.

Note: When the middle frame is coming down to floating area, there is a risk that the rear frame jumps up. If this happens the system stops and d012 can be seen in the display. Move the sliding arm slowly more forwards or backwards to get the rear frame down.

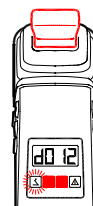

Unloading of a rear heavy flatrack/body

When unloading a long or rear heavy flatrack/body to the ground, move the hook arm forward before the flatrack/body touches the ground. Otherwise there is a danger of the flatrack/body becoming loose from the hook.

Loading of a front heavy container

When loading a too front heavy container it might happen, that the equipment is not strong enough to carry out the loading, although the total weight of the container and the load would not exceed the maximum allowed. In this case move the load closer to the centre of the container, if possible.

Loading a flatrack/body onto a trailer or platform

Sliding a flatrack/body onto a trailer or a platform must be done in **MANUAL MODE A5**.

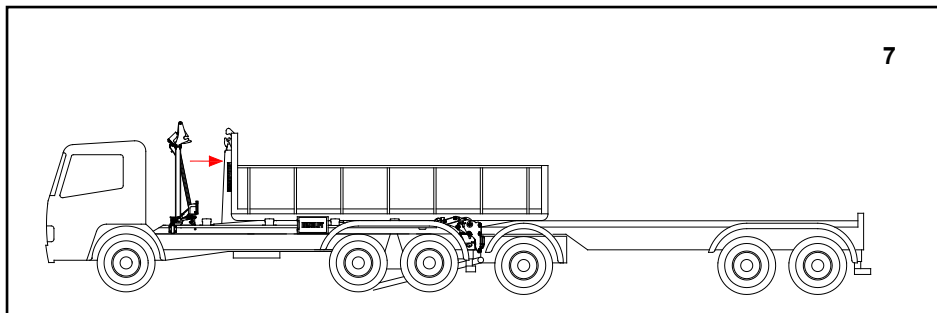
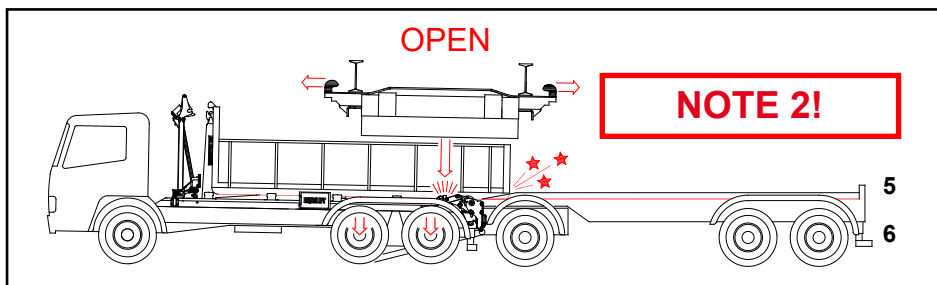
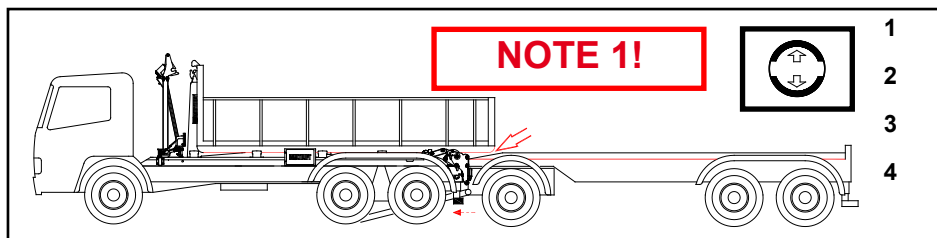

1. **Reverse the truck so that the rear part of the flatrack/body is above the trailer or the platform.**

NOTE 1!

The trailer or platform must be below the sliding level of the hooklift equipment.

2. **Check to be sure that the truck and the trailer/platform are in a straight line.**
3. **Engage the parking brake.**
4. **Engage the hydraulic pump.**

NOTE 2!

If the vehicle is equipped with automatic air suspension bleeding, then ensure that the sliding level of the hooklift interchangeable body is not below the level of the trailer or the platform.

M

MANUAL MODE

5. **Choose manual mode A5**, push the A5 button for approx. 2 s.
6. **Open the hydraulic body locks**
 - press the "bodylocks open" button
 - under-run bar is retracted, if it is not in
 - URB signal light on the control unit is lit, when the under-run bar is fully in the in position
 - "locks not closed" signal light is lit on the control unit when the locks are open.
7. **Drive the sliding frame to the rear position**
 - push the rearmost button in the bottom row on the left side of the control unit
 - horizontal movement slides backwards (cylinder in)
 - mechanical tipping lock opens when the hook frame is in rear position.
 - start at idle speed and then increase the engine speed gradually.

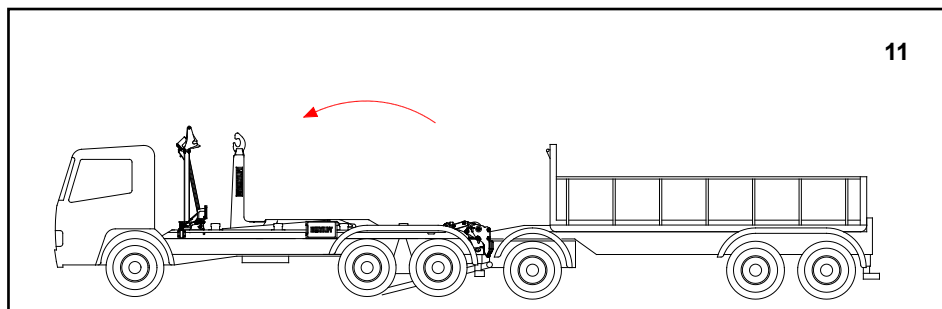
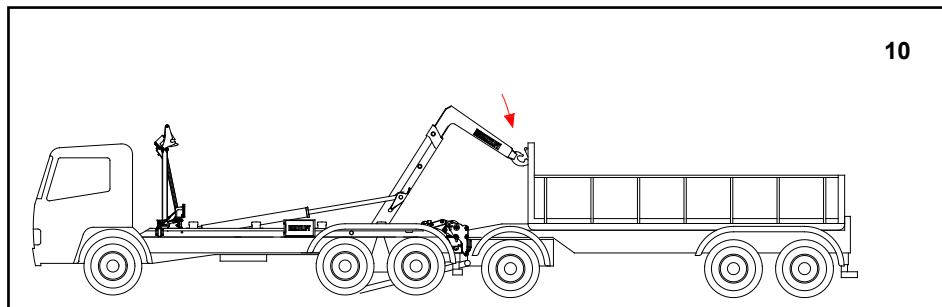
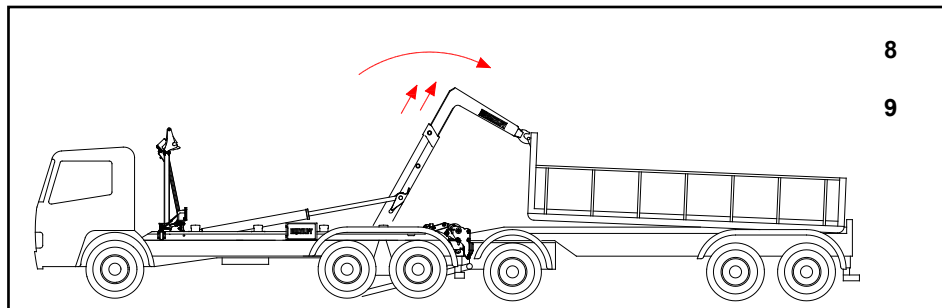

NOTE! If there is a safety code CXXX and/or dXXX in the display, then see the chapters "Safety codes" after the chapters "Loading a container", "Tipping a container" and "Unloading a container".

M

8. **Move the hook frame/middle frame with the flatrack/body backwards**
 - drive the middle frame by moving the control lever back (main cylinders out)
 - "frame not down" signal light is lit as the middle frame is lifted from the sub frame
 - continue the movement until the front of the flatrack/body is almost down.

9. **Keep the flatrack/body front end up and slide it backwards**
 - use horizontal movement in turns by pushing the rearmost button in the bottom row on the left side of the control unit
 - or the middle frame by moving the control lever backwards.

Continue the movement until the flatrack/body stands completely on the trailer or on the platform.

10. **Open the safety lock of the gripping hook, move the hook/middle frame a bit more and release the hook from the flatrack/body gripping bar**
 - open the safety lock of the gripping hook by pressing the button on the control unit just before the front of the flatrack/body is lowered to the ground
 - continue the main cylinder movement with the safety lock open and downward until the hook is released from the gripping bar
 - stop the movement by releasing the control lever.

11. **Move the sliding frame/middle frame to forward position**
 - keep the control lever in front position until the entire body rests on the sub frame
 - "frame not down" signal light on the control unit goes out, when the middle frame comes down.

12. **Move the sliding frame forwards**
 - push the front button in the bottom row on the left side of the control unit.

Continue the movement until the frame is in the forward position.
The hooklift equipment is now in transport position.

13. **Close the hydraulic body locks**
 - press the "body locks closed" button
 - signal light "locks not closed" must go out.

14. **Shut off the oil supply of the hydraulic pump.**

15. **Check that all signal lights of the control unit have gone out.**

LIFTFRAME USAGE

Appropriate ISO container types

The XR21S CHU equipment can be used to transport ISO 668 certified ISO containers, with the following dimensions:

Type IC

Length (L) 20 ft 6058 mm

Width (W) 8 ft 2438 mm

Height (H) 8 ft 2438 mm

Type ICC

Length (L) 20 ft 6058 mm

Width (W) 8 ft 2438 mm

Height (H) 8 ft 6 in 2591 mm

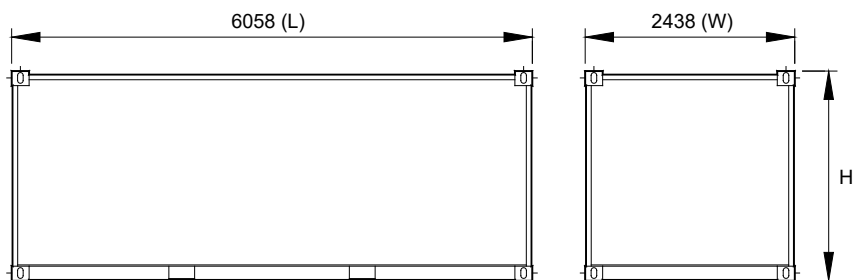

The XR21S emergency stop switch
(stops the handling functions of a demountable and an ISO
container)

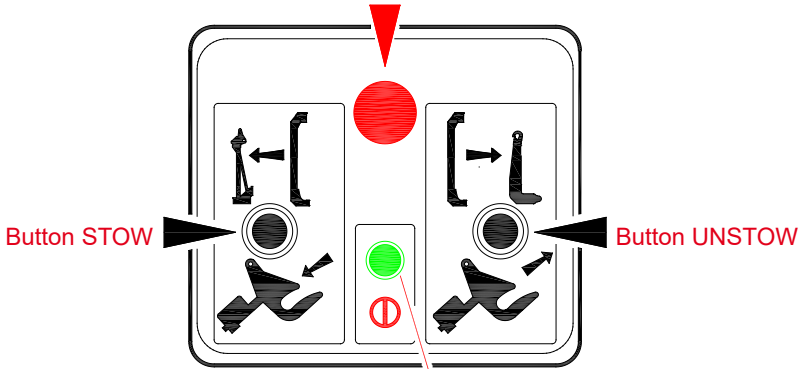

Stowage control unit

Signal light "POWER ON"

The light is lit when the stowage mode (A4)
or the manual mode (A5) is selected.

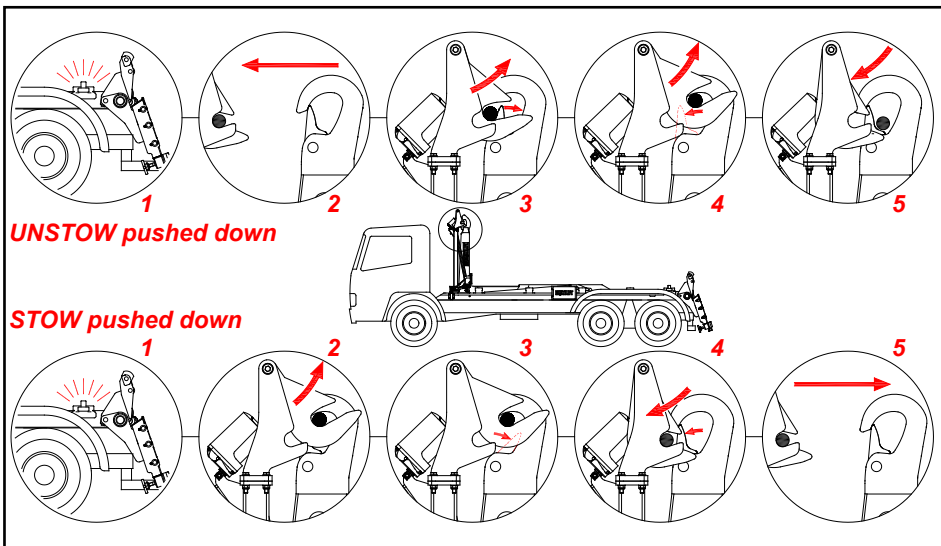

UNSTOW / STOW phases

Buttons on the stowage control unit

The emergency stop switch of the equipment

(effects all XR21S equipment functions, and demountable and ISO container handling)

- pressing the emergency stop switch will stop the movement of the XR21S equipment at any time.
- when the dangerous situation causing the emergency stop has passed, work can continued by releasing the emergency stop switch back to the operation position.

The UNSTOW and STOW buttons on the control unit

Press the UNSTOW button without releasing it:

- 1: body locks open if they are still closed
- 2: horizontal movement moves to the stow/unstow position
- 3: the stowage actuator turns the stowage hook up and lifts the liftrframe from the stowage to the XR21S gripping hook
- 4: the safety lock of the XR21S gripping hook locks the liftrframe to the gripping hook of the equipment
- 5: the stowage actuator turns the stowage hook down

Press the STOW button without releasing it:

- 1: body locks open if they are still closed
- 2: the stowage actuator turns the stowage hook up and lifts the liftrframe from the XR21S gripping hook
- 3: the safety lock of the XR21S gripping hook opens and remains so, until the stowage hook has returned to the down position
- 4: the stowage actuator turns its hook down and brings the liftrframe onto the stowage
- 5: horizontal movement goes to the flatrack home position (approx. 350 mm from the stow/unstow position of horizontal movement).

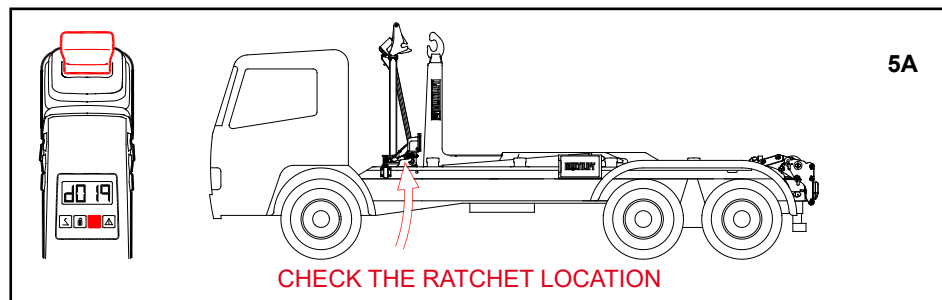
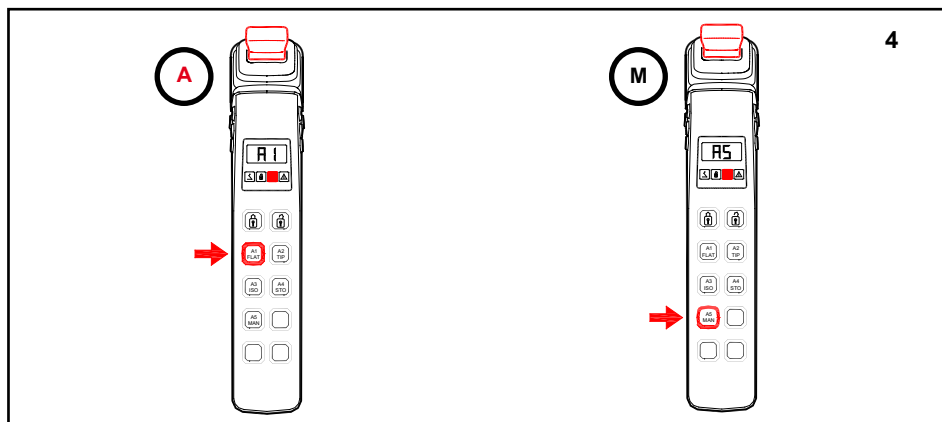
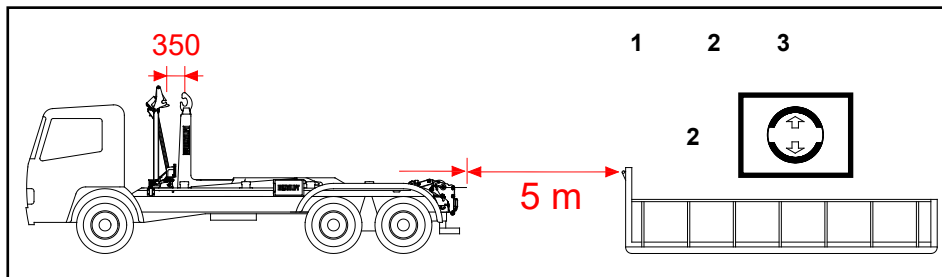

Fetching the liftframe with the XR21S hook, moving it and locking it to the stowage

XR21S EQUIPMENT IS IN TRANSPORT POSITION WHEN STARTING MOVEMENTS
During flatrack/body change the horizontal movement is in flatrack home position (approx. 350 mm behind the stow/unstow position).

The recommended pump running speed is between 1000 - 1400 k/min. Let the engine run at idle speed at the beginning and end of movements and when using the locks.

1. **Reverse the truck carefully close to the liftframe.**
Stop it about 5 meters from the liftframe gripping bar.
2. **Engage the parking brake.**
3. **Engage the hydraulic pump.**

AUTOMATIC MODE A1

A

- 4 **Choose automatic mode A1**
- push the A1 button for approx. 2 s.

MANUAL MODE A5

M

- 4 **Choose manual mode A5**
- push the A5 button for approx. 2 s.

- 5A. **If it seems impossible to select the mode and code "d019" is displayed on the control unit, make sure that the attachment joints of the liftframe ratchets are attached to the stowage.**

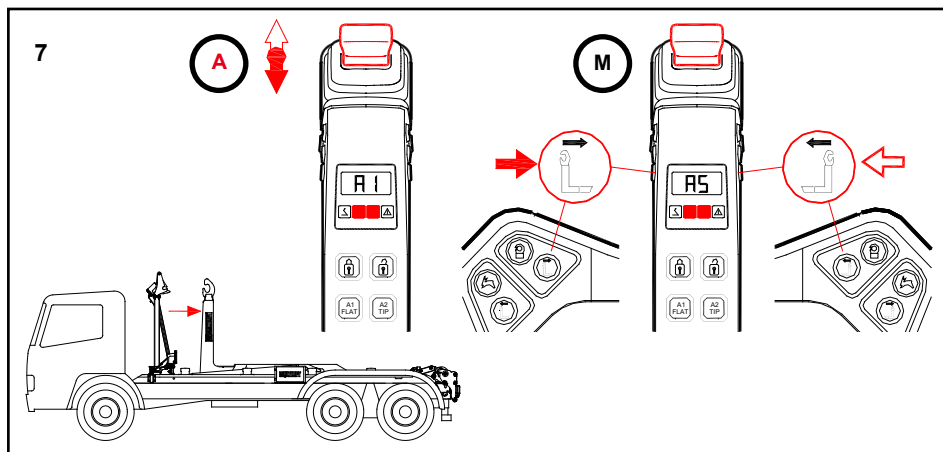
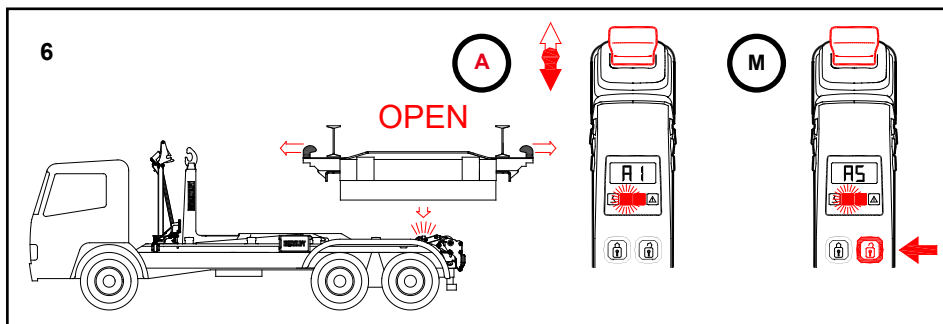
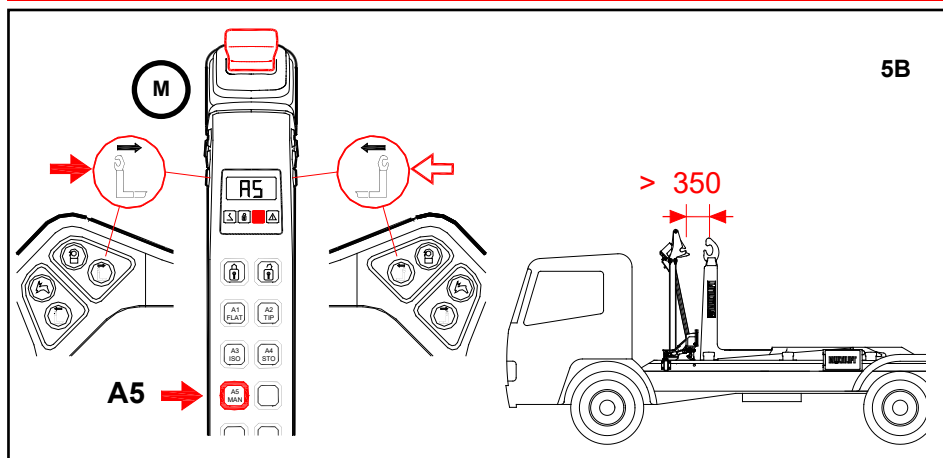

M

5B. **Select manual mode A5 in case the horizontal movement has been driven to the stow/unstow position, in front of the flatrack/body home position.**

- push the A5 button for approx. 2 s.
- push the rearmost button in the bottom row on the either side of the control unit
- horizontal movement slides backwards (cylinder in)
- stop the horizontal movement after it has moved at least 350 mm backwards

A

6. **Opening body locks**

- *move the control lever slowly backwards*
- *the body locks open*
- *“locks not closed” signal light on the control unit is lit, when the locks are fully open.*

M

6. **Open the body locks**

- push the “bodylocks open” button
- “locks not closed” signal light on the control unit is lit, when the locks are fully open.

A

7. **Horizontal movement into rear position**

- *keep the control lever in rear position*
- *horizontal movement slides backwards (cylinder in)*
- *mechanical tipping lock opens when the hook frame is in rear position.*

M

7. **Drive the horizontal movement into rear position**

- push the rearmost button in the bottom row on the either side of the control unit
- horizontal movement slides backwards (cylinder in)
- mechanical tipping lock opens when the hook frame is in rear position.

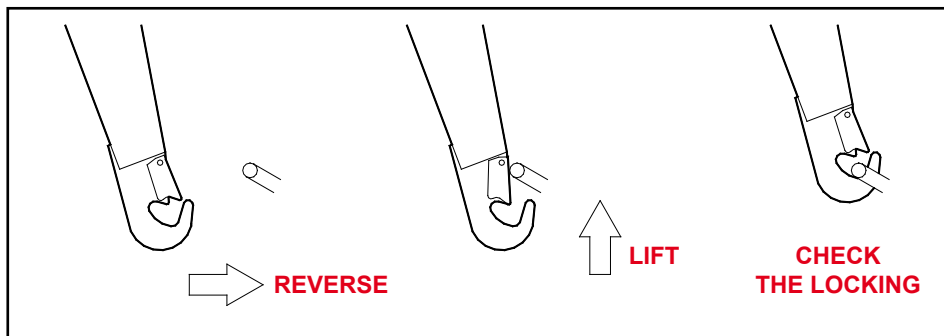
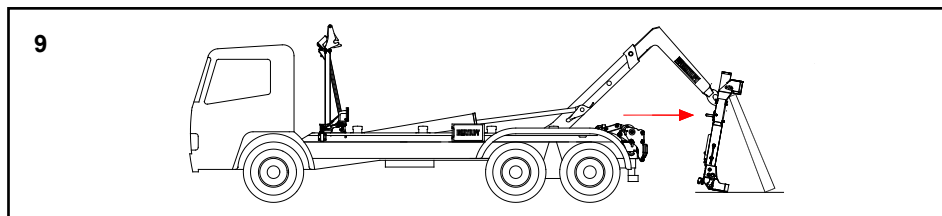
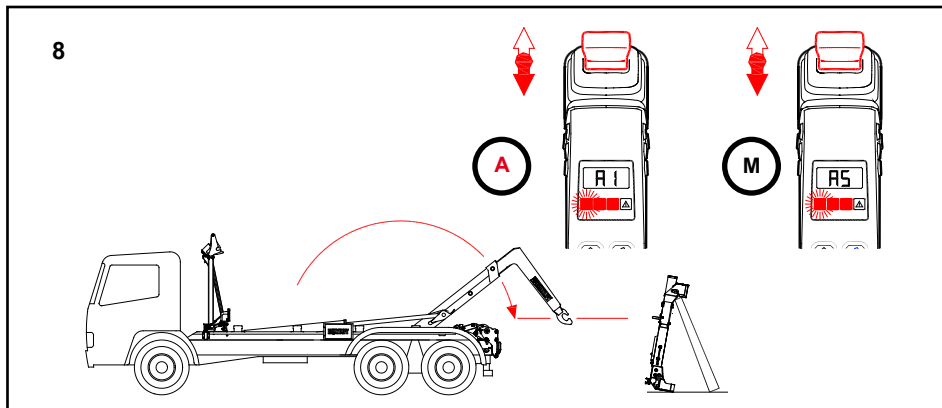

A

8. Middle frame back

- keep the control lever in rear position. Middle frame turns back (main cylinders out).
- "frame not down" signal light is lit, when the middle frame is lifted off the sub frame
- stop the movement by releasing the control lever, when the hook is slightly below the liffframe gripping bar.

M

8. Drive the middle frame back

- drive the middle frame back by moving the control lever back (main cylinders out).
- "frame not down" signal light is lit, when the middle frame is lifted off the sub frame
- stop the movement by releasing the control lever, when the hook is slightly below the liffframe gripping bar.

9. Gripping the liffframe gripping bar

(manual mode A5 and automatic mode A1)

- reverse the truck carefully, until the hook frame comes close to the liffframe gripping bar.



DO NOT TIP OVER THE LIFFFRAME!

Ask another person to monitor the grabbing of the liffframe and receive the liffframe support when it is released.

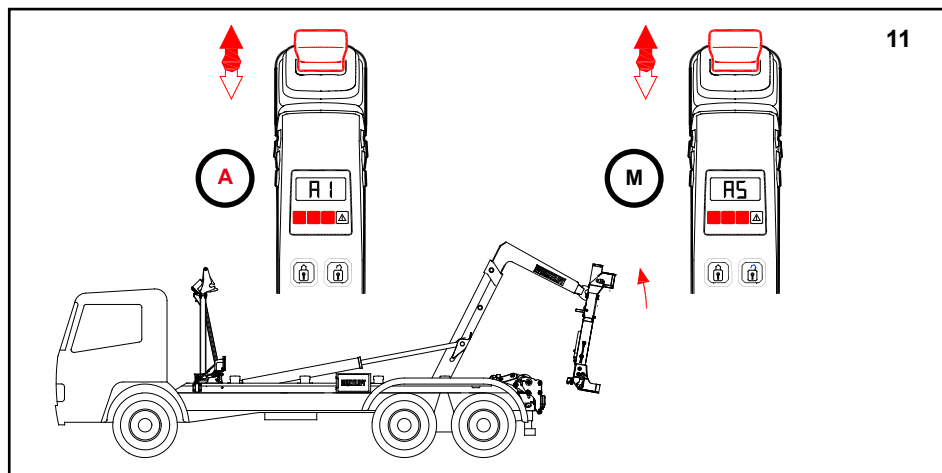
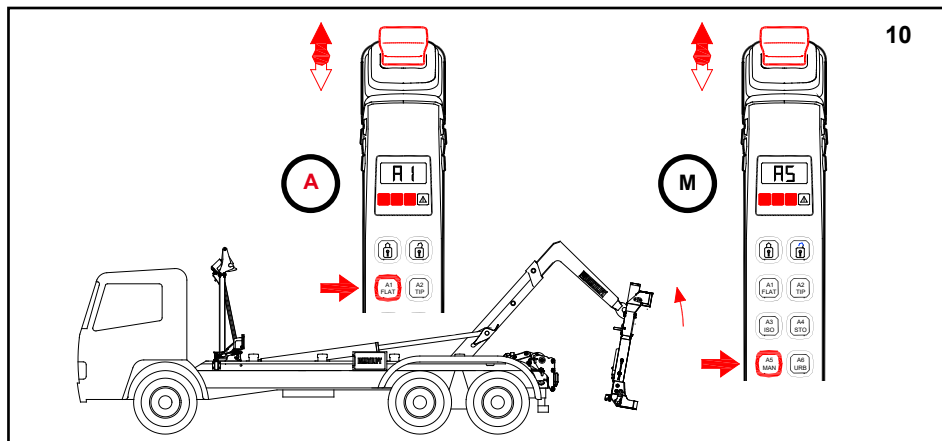

A

Choose automatic mode A1

- push the A1 button for approx. 2 s.

10. The liffframe comes free from the ground

- move the control lever slowly forward
- signal lights "locks not closed", "URB in" and "frame not down" on the control unit are lit
- main cylinder piston rods move inwards.

Safety lock of the gripping hook gives way to the gripping bar pushing into the hook.

- release the control lever when the hook starts to lift the liffframe.

Make sure that the gripping bar is properly inside the lifting hook and the safety lock is engaged.

M

Select manual mode A5

- push the A5 button for approx. 2 s.

10. Lifting the liffframe from the ground

- move the control lever forward (main cylinders in)
- signal lights "locks not closed", "URB in" and "frame not down" on the control unit are lit
- the main cylinder piston rods move inwards.

Safety lock of the gripping hook gives way to the gripping bar pushing into the hook.

- release the control lever when the hook starts to lift the liffframe.

Make sure that the gripping bar is properly inside the lifting hook and the safety lock is engaged.

A

11. Middle frame forward (beginning of the movement)

- move the control lever forward
- the main cylinder piston rods move inwards.

M

11. Middle frame forward (beginning of the movement)

- move the control lever forward
- the main cylinder piston rods move inwards.

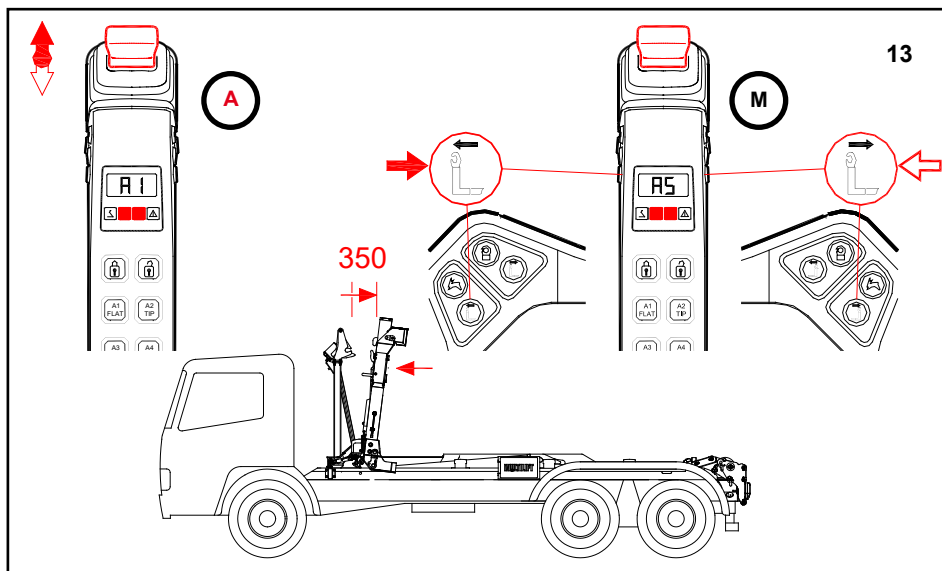
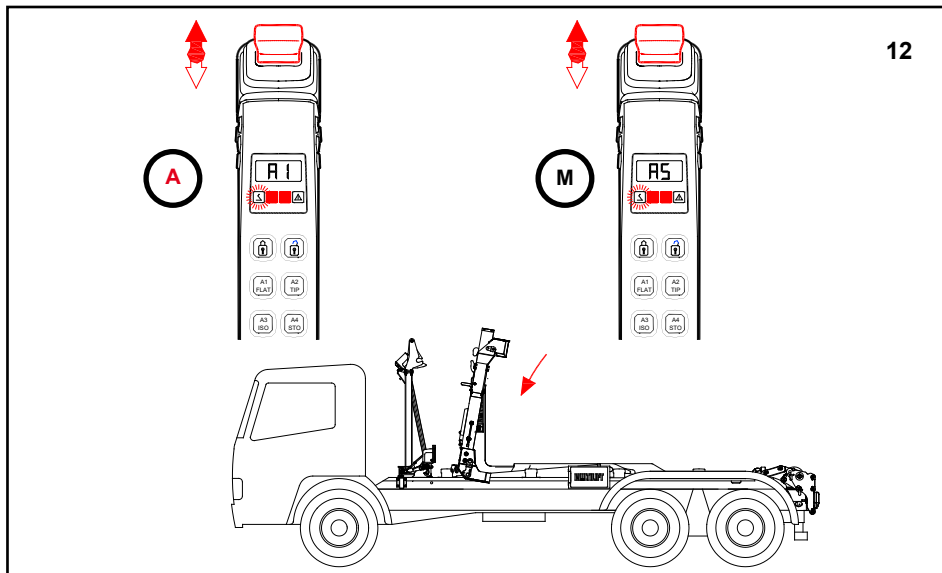

A

**12. Middle frame forward
(end of the movement)**

- keep the control lever in front
- main cylinder piston rods move inwards.
- “frame not down” signal light on the control unit goes out, when the middle frame comes down.

The speed of lowering the middle frame must be reduced by lowering the engine speed in the last phase of the main cylinder movement.

The main cylinders are released (floating) when the middle frame is about 60 mm above the body supports, and the final stage of unloading is dampened.

M

**12. Middle frame forward
(end of the movement)**

- keep the control lever in front
- main cylinder piston rods move inwards
- “frame not down” signal light on the control unit goes out, when the middle frame comes down.

The speed of lowering the middle frame must be reduced by lowering the engine speed in the last phase of the main cylinder movement.

The main cylinders are released (floating) when the middle frame is about 60 mm above the body supports, and the final stage of unloading is dampened.

A

13. Horizontal movement forward

- keep the control lever in the front (telescope cylinder out).

Release the switch when the system has stopped the horizontal movement.

M

13. Horizontal movement forward

- by pushing the front button in the bottom row on the either side of the control unit (telescope cylinder out)

Release the button when the horizontal movement has reached the flatrack/body home position (approx. 350 mm from the stow/unstow position of horizontal movement).

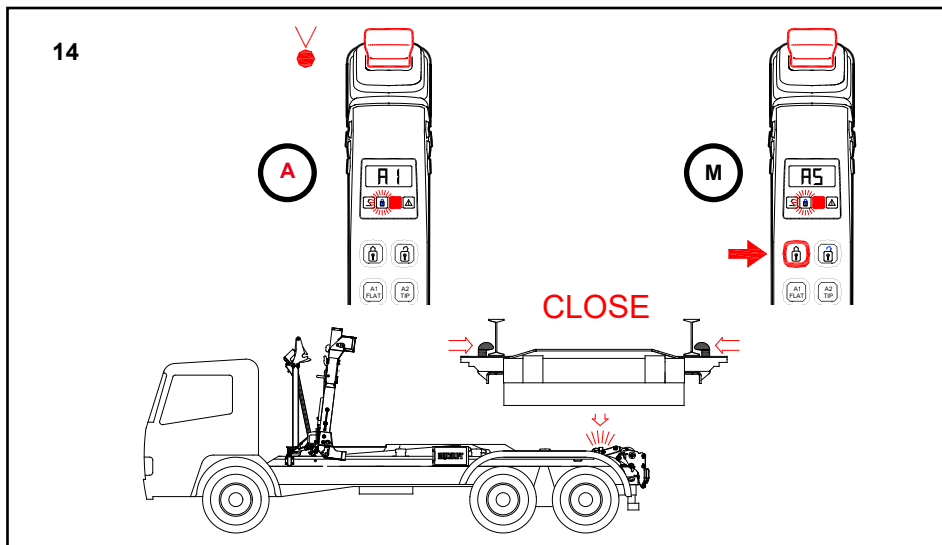

A

14. Closing body locks

- *body locks close when the control lever is released*
- *the "locks not closed" signal light on the control unit goes out.*

M

14. Closing body locks

- close the body locks by pressing the "bodylocks close" button
- the signal light "locks not closed" should go out.

Move and lock the lifftframe to the stowage in accordance with sections "Moving the lifftframe onto the XR21S stowage" and "Locking the lifftframe to the stowage", unless the ISO container to be lifted is in the immediate vicinity of the vehicle.

Moving the lifftframe onto the XR21S equipment's hook

XR21S EQUIPMENT IN TRANSPORT POSITION AND THE LIFTFRAME ON THE STOWAGE WHEN STARTING MOVEMENTS

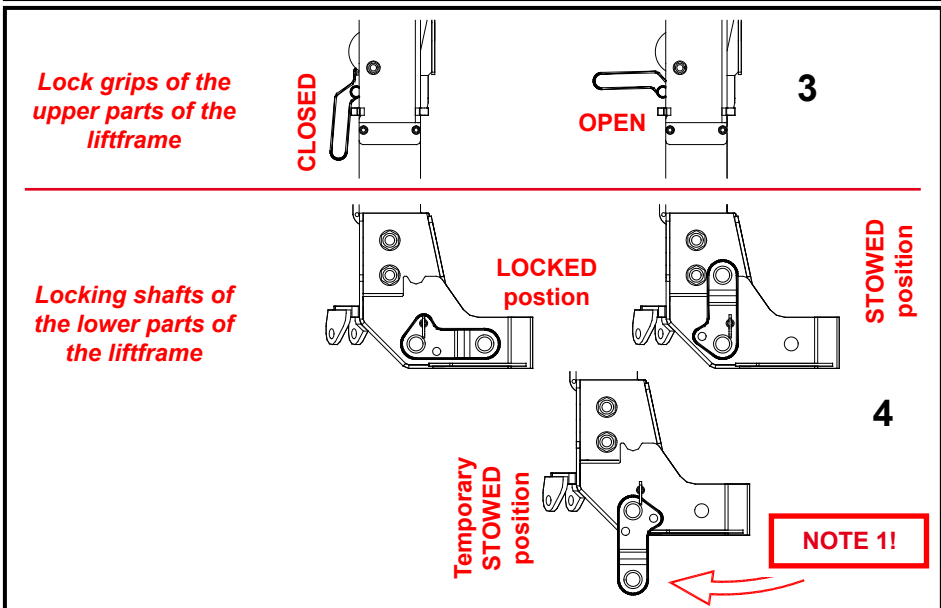
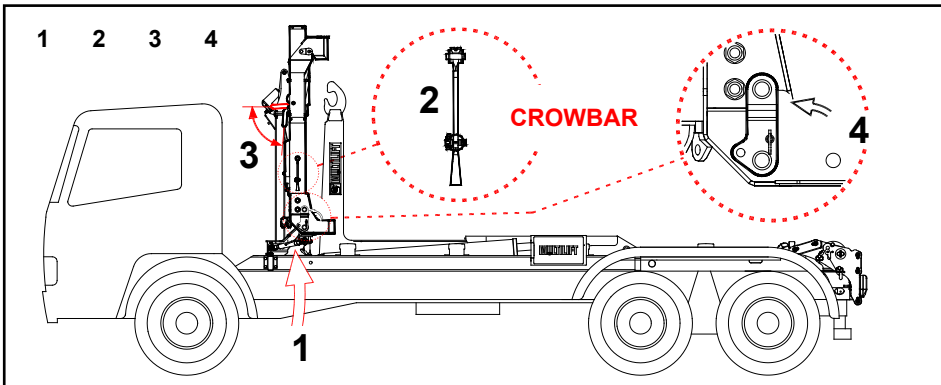

Opening the lift frame stowage lock

If the lift frame is in the XR21S hook (the liftframe has been picked up from the immediate vicinity of the vehicle), continue to section "Lifting the ISO container".

1. First rotate the middle sections of the ratchets enough to loosen them.
2. If needed, take the crowbar attached to the left side of the liftframe and remove the dirt and ice from the areas where the ISO container and body are attached.

The crowbar may also be used to extract the locking shaft. The locking shaft may not be detached at this stage.

3. Turn the lock grips on the telescopic upper parts, on the surface of the lifting frame's vertical beams, into **OPEN position** (grips horizontally, images 3).

It is recommended to keep the lock grips in **OPEN position** when driving the truck without an ISO container. The liftframe is then at its lowest.

4. Extract the locking shafts on the lower parts of the liftframe using the crowbar if necessary. Turn the axis on both sides of the equipment to 180° **temporary STOWED position** (lock plates vertical, images 4), **note** leave the whole pin extracted so the liftframe can move in front of the stowage.

NOTE 1!

Leave the locking shaft into the **temporary STOWED position** only while you remove the locking pin (phase 5), and then turn it into the **STOWED position** (phase 7).

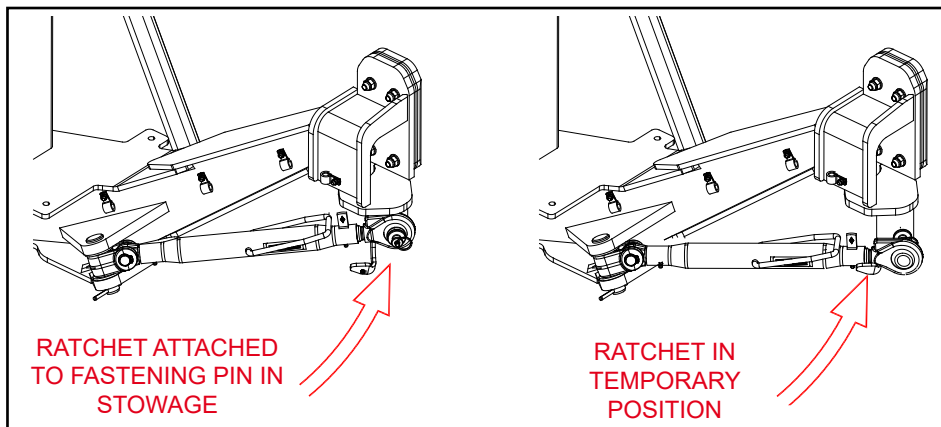
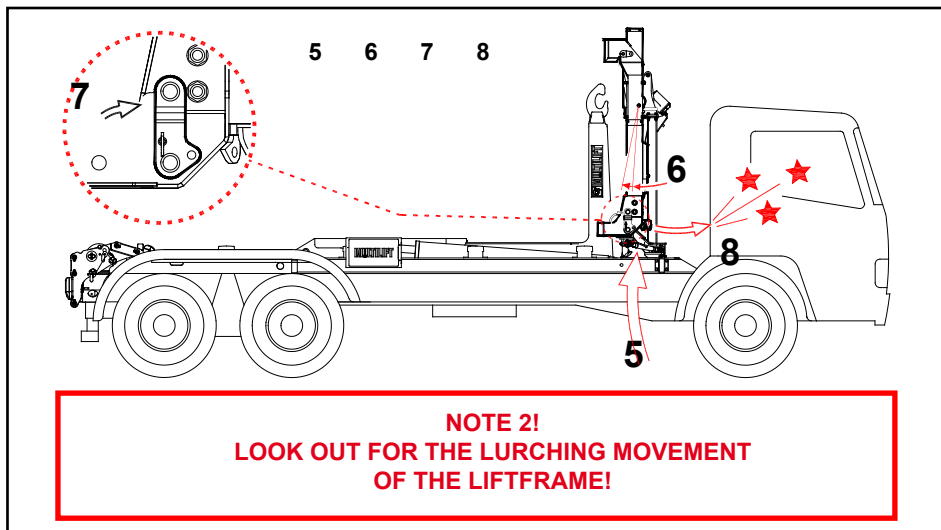

5. Disconnect the right ratchet from the liftframe and place it temporarily on the suspension hook on the stowage.
6. Move the bottom part of the liftframe back while rotating the middle section of the LH ratchet long enough to have the locking shafts behind the attachment joints of the stowage.
7. Turn the locking shafts on the bottom parts of the liftframe to their **STOWED position** (locking plates vertically).
8. Disconnect the left ratchet and temporarily place it on the stowage suspension hook so that the ratchet locking pins are in place (locking position).

NOTE 2!

After releasing the locking shafts and pins, the liftframe will lurch towards the cockpit of the vehicle. MIND your hands!

Proceed to control the equipment with the stowage control box buttons.

Moving to the XR21S hook

Let the engine run **at idle speed during** lifframe movement.



NOTE!

Unnecessary use of the main pressure relief valve should be avoided, because it may overheat the oil.

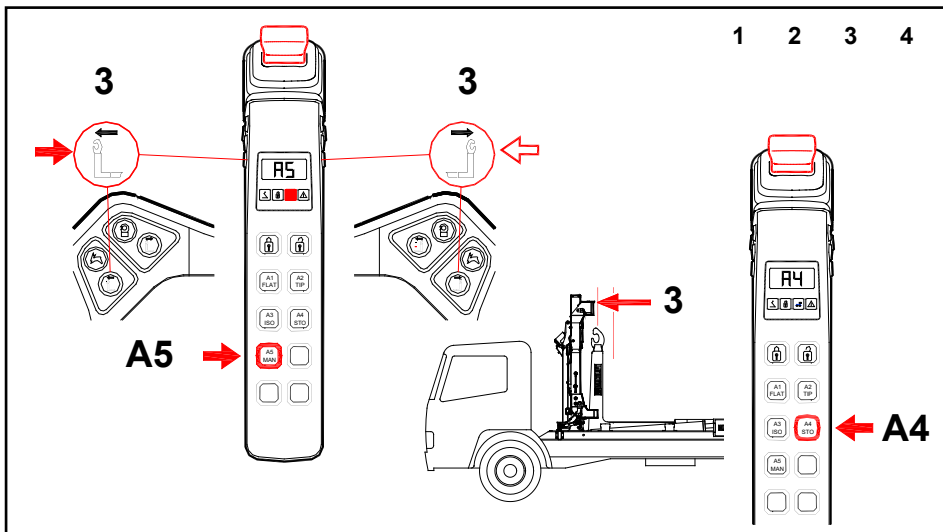

Emergency stop switch

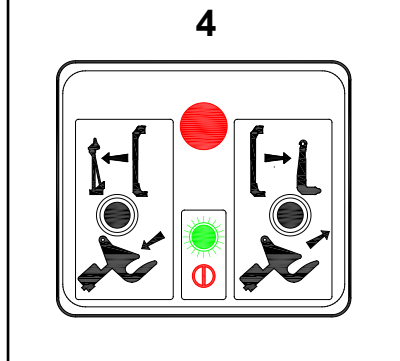
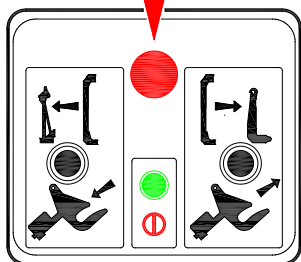

1. **Check the safety of the working area.**
2. **Engage handbrake and hydraulics.**
3. **Make sure that the horizontal movement is in the flatrack home position** (approx. 350 mm from the stow/unstow position).

Perform this phase in manual mode A5.

If necessary, drive the horizontal movement forward by moving it or by pushing the front button in the bottom row on the either side of the control unit.

4. **Engaging stowage mode A4**

Choose mode A4

- push the A4 button shortly
- code "A4" is lit on the XR21S equipment control unit display
- green signal light "power on" is lit on the stowage control unit.

If it seems impossible to select the mode and code "d019" is displayed on the control unit, make sure that the attachment joints of the liftrframe ratchets are attached to the stowage.



NOTE!

An emergency stop switch can be found on the stowage control unit. Pushing it will stop the movement of the XR21S equipment at any time.

When the dangerous situation causing the emergency stop has passed, work can continued by releasing the emergency stop switch back to the operation position.

EMERGENCY STOP SWITCH

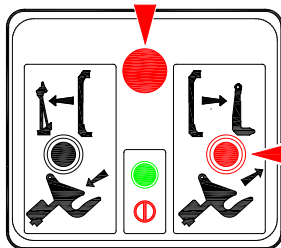

UNSTOW
BUTTON

5

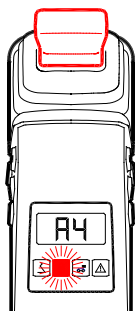

5.1

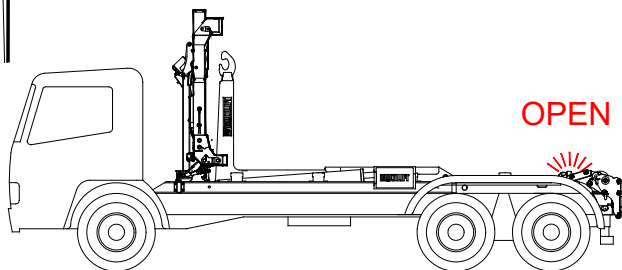

OPEN

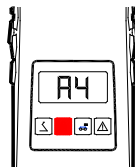

5.2

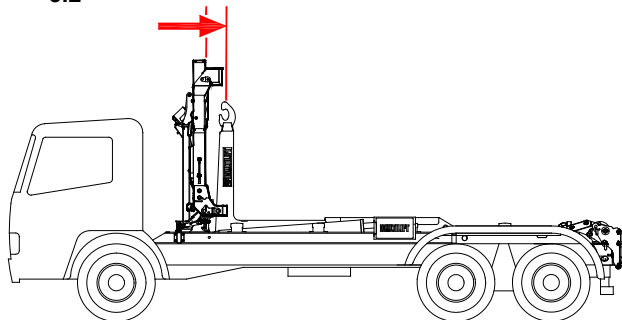

5 Pushing the lifftframe in the hook

Code "A4" is displayed on the XR21S equipment control unit display is lit.
Green signal light "power on" on the stowage control unit is lit.

Push the UNSTOW button on the stowage control unit without releasing it:

5.1 Opening body locks

The body locks open if they are still closed.

5.2 The horizontal movement goes in the stow/unstow position

Starting from Flatrack position (350 mm behind the stow/unstow position).

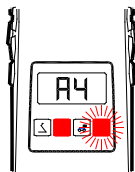

5.3

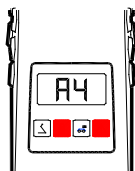
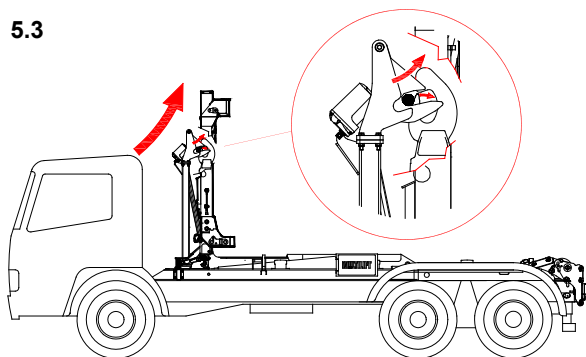

5.4

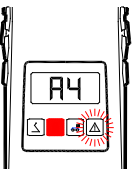
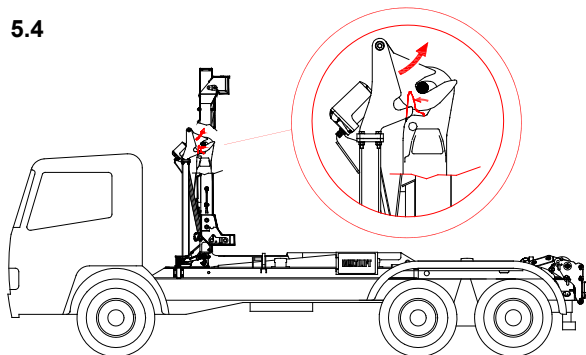

5.5

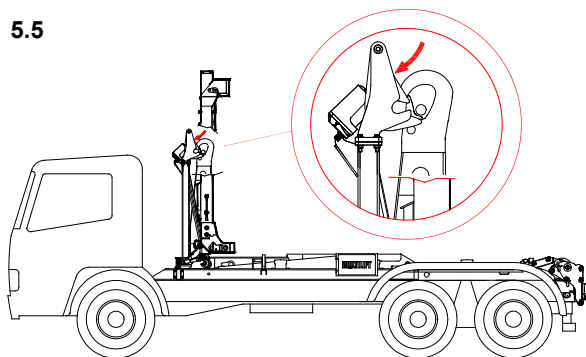

5.3 Lifting the liftrframe onto the gripping hook of the XR21S equipment

The stowage actuator turns the stowage hook up and lifts the liftrframe from the stowage onto the XR21S gripping hook

5.4 Closing the safety lock of the XR21S gripping hook

The safety lock of the XR21S gripping hook locks the liftrframe to the gripping hook of the equipment

5.5 The stowage hook turning downwards

The stowage actuator turns the stowage hook down

Before gripping and loading the ISO container

**CHECK THE ISO CONTAINER SUPPORT ROLLER POSITION ON THE XR21S
-EQUIPMENT BEFORE LOADING AN ISO CONTAINER!**

**LOADING AND UNLOADING AN ISO CONTAINER WITH A XR21S LIFTFRAME
HAS THE SAME PHASES AS HANDLING A FLATRACK/BODY.**

**THE DIFFERENCE BETWEEN HANDLING A FLATRACK/BODY IS,
THAT THE SUPPORT ROLLER CRADLES MUST BE IN CONTAINER
READY POSITION (image 1).**

If the roller is in the flat rack/body change position (picture 2)

- 2 Pull the roller locking pins off (A).
- 3 Turn the front part of the roller to an upright position. Lock it to this position by pushing the shorter locking pin into hole B. Push the longer roller locking pin into hole C to the point, where you can still turn the roller.
- 4 Turn the roller to the flatrack/body change position and push the locking pin to the point where the head of the pin goes into the arched groove in the roller frame.
- 5 **After the operation both locking pins must be locked to their correct positions with lock latches (picture 5).**

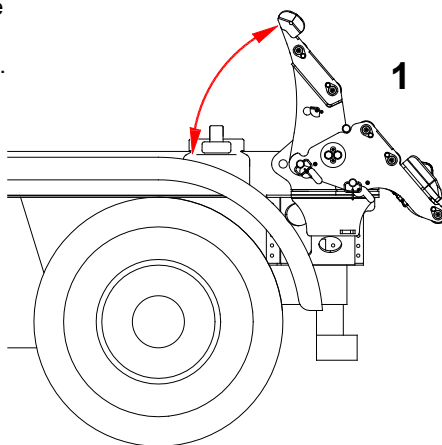

>>>

>>>

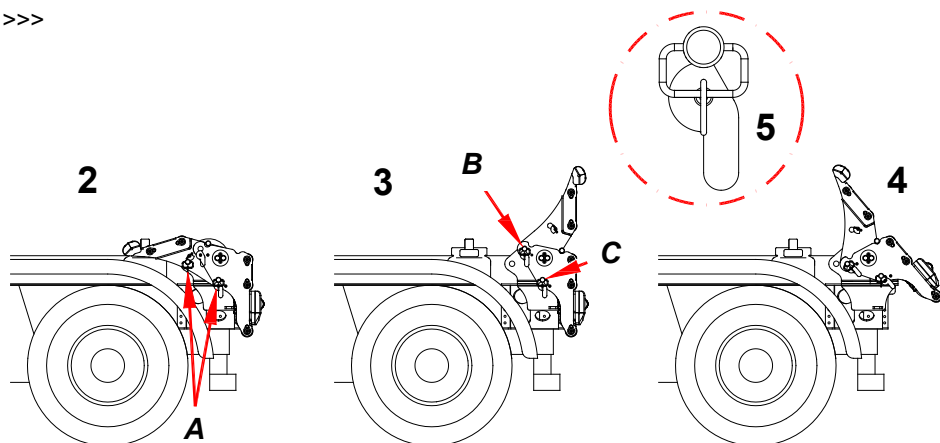

Loading phases

MIDDLE FRAME OF THE XR21S EQUIPMENT RESTS ON THE SUB FRAME AND THE LIFTFRAME IS IN THE GRIPPING HOOK WHEN STARTING MOVEMENTS

During loading the XR21S equipment is controlled seated from the cabin, using the controls inside the truck's cabin.

The recommended pump running speed is between 1000 - 1400 k/min. Let the engine run at idle speed at the beginning and end of movements and while using the locks.

An ISO container can be loaded in **automatic mode A3**, because the length of IC and ICC ISO containers (6058 mm) doesn't require movements in manual mode outside a safe working area.

The final stage of loading a container with a heavy load (more than 10 t), downwards from an angle of approx. 20 degrees, should be done in **manual mode A5**, because it enables horizontal movement forward before lowering the container onto the frame and prevents the bottom bended by the weight from scraping the body of the XR21S equipment.

>>>

>>>



Check the flat bars on forklift pockets of the ISO container to be loaded. These should be intact, straight and properly welded.

Rundown flat bars may prevent unloading a container as the fronts of the rear rollers sink into the container forklift pockets.

Check that the TWISTLOCK clasps in the rear beds of the iso container support rollers are fully in the lock housings.

Continuing the ISO container loading phases

If the ISO container to be loaded is nearby, you can continue according to the instructions in section 1, "Loading phases".

If the truck needs to be moved for more than a few meters, the under sides of the liftframe must be attached with ratchets on both sides of the vehicle in order to prevent the frame from swaying during transport.

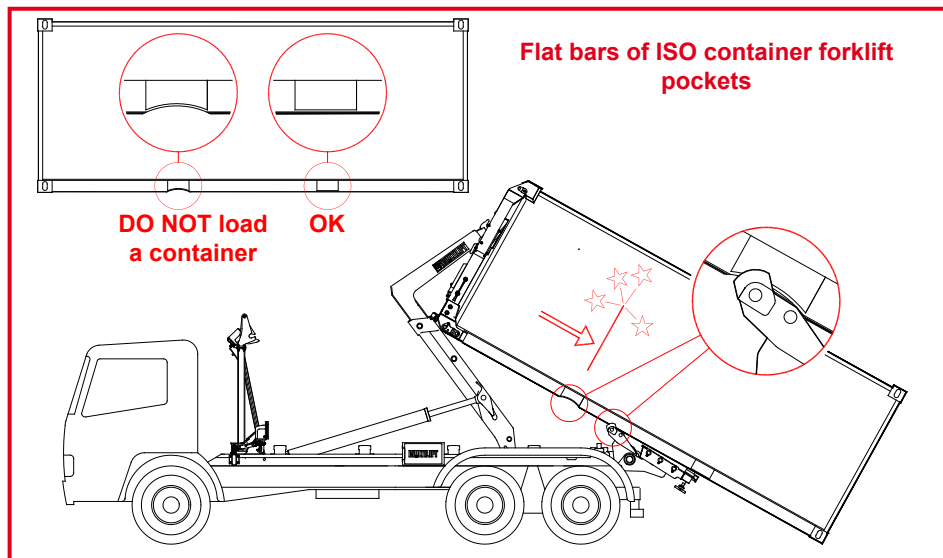

Loading the ISO container

Switch to controlling the equipment with the XR21S control unit.

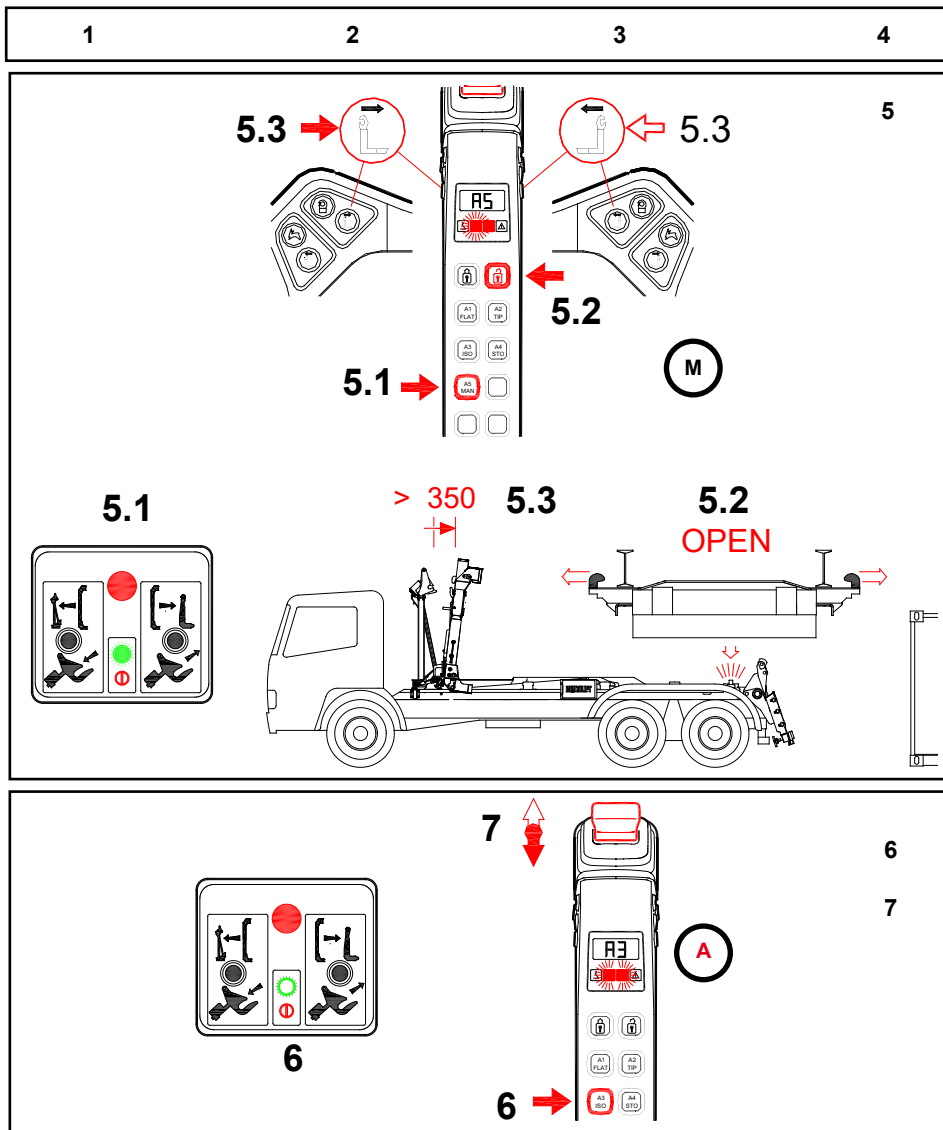

1. **See the safety instructions before loading.**
2. **Reverse the truck to about 5 meters from the container.**
Check the safety of the working area.
3. **Activate the handbrake.**
4. **Engage the hydraulic pump.**

M

5. **Horizontal movement out** (only in manual mode A5).
 1. **Choose manual mode A5**, push the A5 button for approx. 2 s.
 - code "A5" is lit on the XR21S equipment control unit display
 - green signal light "power on" is lit on the stowage control unit.
 2. **Open the body locks**
 - push the "bodylocks open" button
 - "the "locks not closed" signal light on the control unit is lit, when the locks are open.
 3. **Drive the horizontal movement cylinder in**
 - push the rearmost button in the bottom row on the either side of the control unit, until the horizontal movement goes to the flatrack home position (approx. 350 mm from the stow/unstow position of horizontal movement).

A

AUTOMATIC MODE A3

6. **Select automatic mode A3**
 - *push the A3 button approx 2 s*
 - *"power on" signal light on the stowage control unit goes out.*
7. **Opening body locks**
 - *move the control lever slowly backwards*
 - *under-run bar is retracted, if it is not in*
 - *URB signal light on the control unit is lit, when the under-run bar is in the in position*
 - *the system attempts to open the body locks*
 - *"locks not closed" signal light on the control unit is lit, when the locks are fully open.*

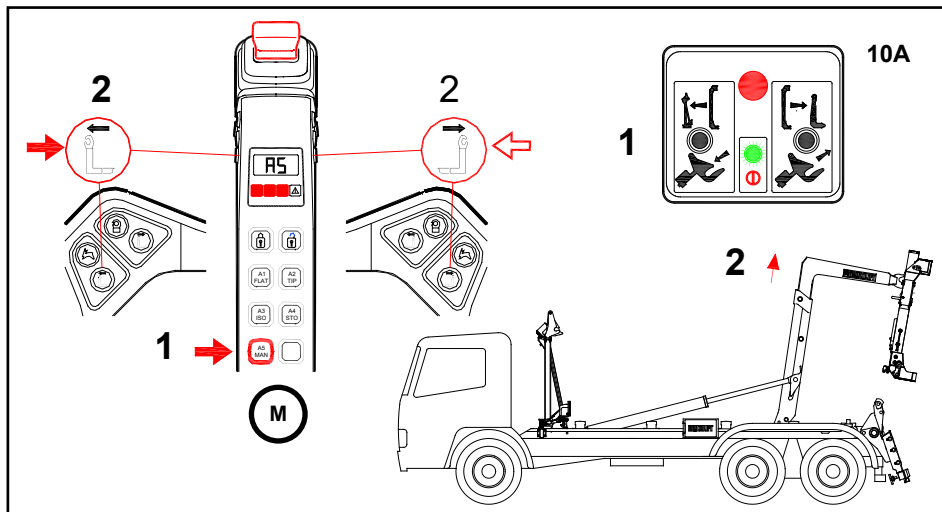
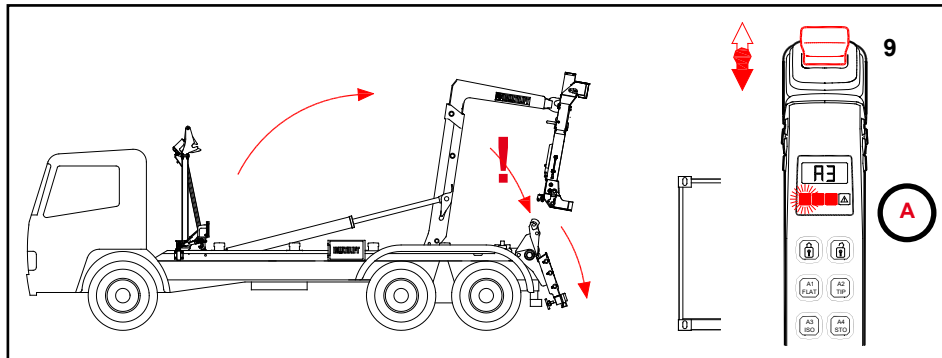
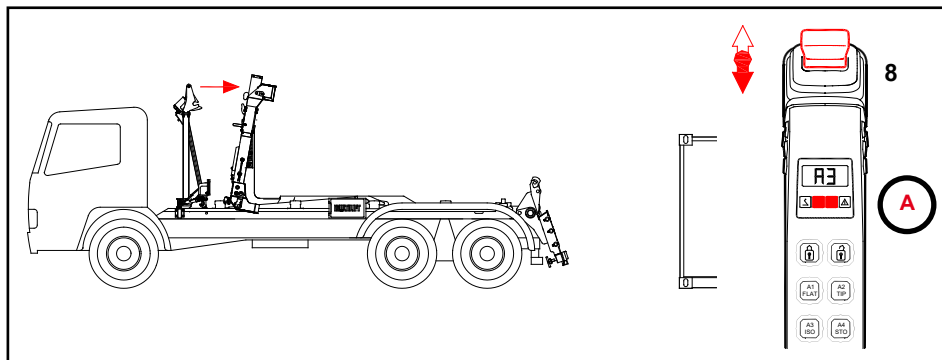

A

8. Horizontal movement into rear position

- keep the control lever in rear position
- horizontal movement slides backwards (cylinder in)

- mechanical tipping lock opens when the hook frame is in rear position.

9. Middle frame back

- keep the control lever in rear position
- middle frame turns back (main cylinders out)
- "frame not down" signal light is lit, when the middle frame is lifted off the subframe.

Stop the movement by releasing the control lever, when the container locking pins on the telescopic upper sides of the liftframe are a little above the containers upper corners.



Monitor the lower ends of the liftframe during the movement. If the body is in danger of colliding with the rear rollers, stop the movement before colliding and continue according to sections 10A and 10B.

M

10A. Driving the horizontal movement outwards
(only in manual mode A5).

- 1. Choose manual mode A5**, push the A5 button for approx. 2 s.
 - green signal light "power on" is lit on the stowage control unit.
- 2. Drive the horizontal movement cylinder out**
 - by pushing the front button in the bottom row on the either side of the control unit, in order to avoid the risk of a collision.

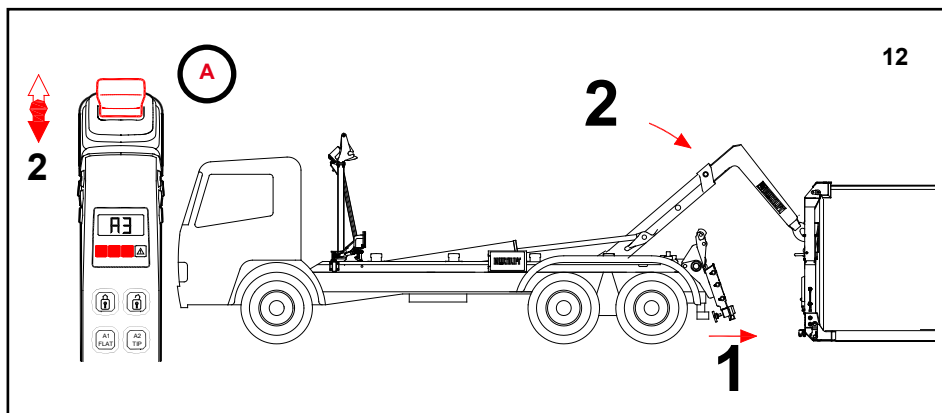
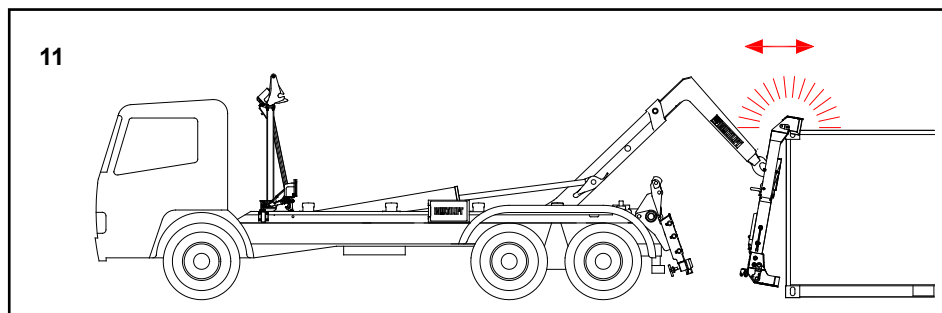
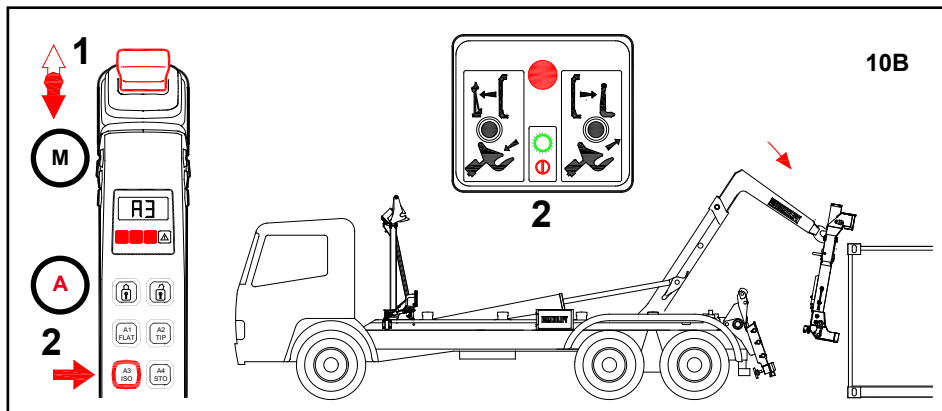

M

10B1. Driving the middle frame backwards

- Continue the middle frame movement by moving the control lever backwards, enough to prevent a collision.

A

10B2. Change to *automatic mode* in the end by selecting *mode A3*

- *“power on” signal light on the stowage control unit goes out.*

Perform the middle frame movement to just above the upper corners of the container, as explained in section 9.

11. If needed, move the truck sideways or lengthwise, until the control flanges of the telescopic upper sides of the liftrframe are beside the upper corner boxes of the container and the container locking pins are next to the container corner box openings.

The truck and the ISO container must be exactly parallel.

A

12. Liftrframe attached to ISO container 1

1. Reverse the truck so that the control flanges on the lower parts of the liftrframe move along the exterior of the lower container corner boxes to the sides of the container. Continue reversing until the lower part of the liftrframe comes against the container.

2. *Continue in automatic mode A3.*

- *move the control lever into rear position in order to lower the liftrframe further and to get the container locking pins on its telescopic upper parts into the container corner box openings. Continue the movement downwards.*

Stop the movement by releasing the control lever when the lower ends of the liftrframe reach the ground.

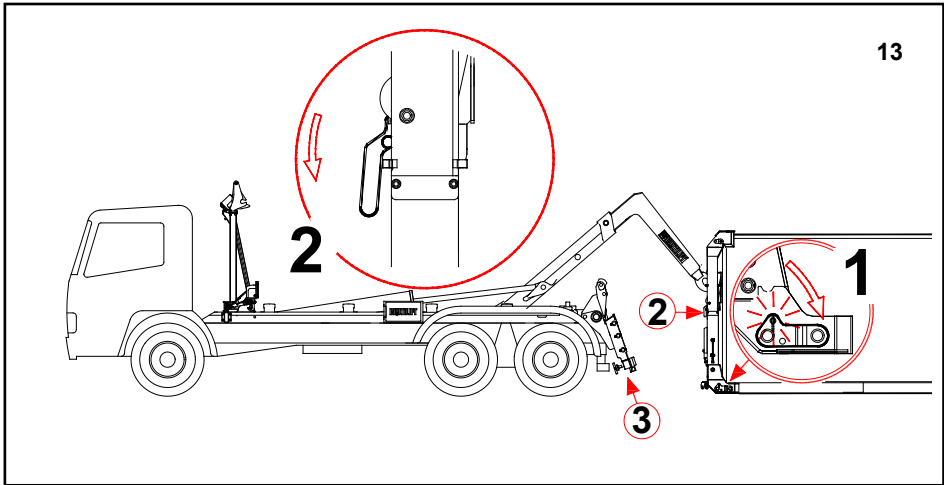

During transport of ISO-containers the lift frame must always be locked at the front by the 2 ratchets mounted to the stowage. Because an ISO-container locked at all four corner castings is limiting the flexibility of the chassis, and can cause high stresses in ratchets and twistlocks, off road driving with an ISO-container must be performed at low speed.

13. Liffframe attached to the ISO container 2

1. Turn the locking shafts on the lower parts of the lifftframe on both sides of the equipment 90° downward from their **STOWED position** to their **LOCKED position** into the container.
2. Turn the lock grips on the telescopic upper parts of the lifftframe back to **locked position** (grips vertically).
3. Check before loading, that the TWISTLOCK clasps are inside the lock mechanisms.



The TWISTLOCK clasp protruding from the lock mechanism grips the lower structures of the loaded container damaging them and a clasp gripping only one side of the container may cause the **truck to fall** over as the haul is continued.

14. Loading an ISO container on a truck

Follow the instructions in section **Loading a flatrack/body**, when loading a sea container onto the XR21S equipment.

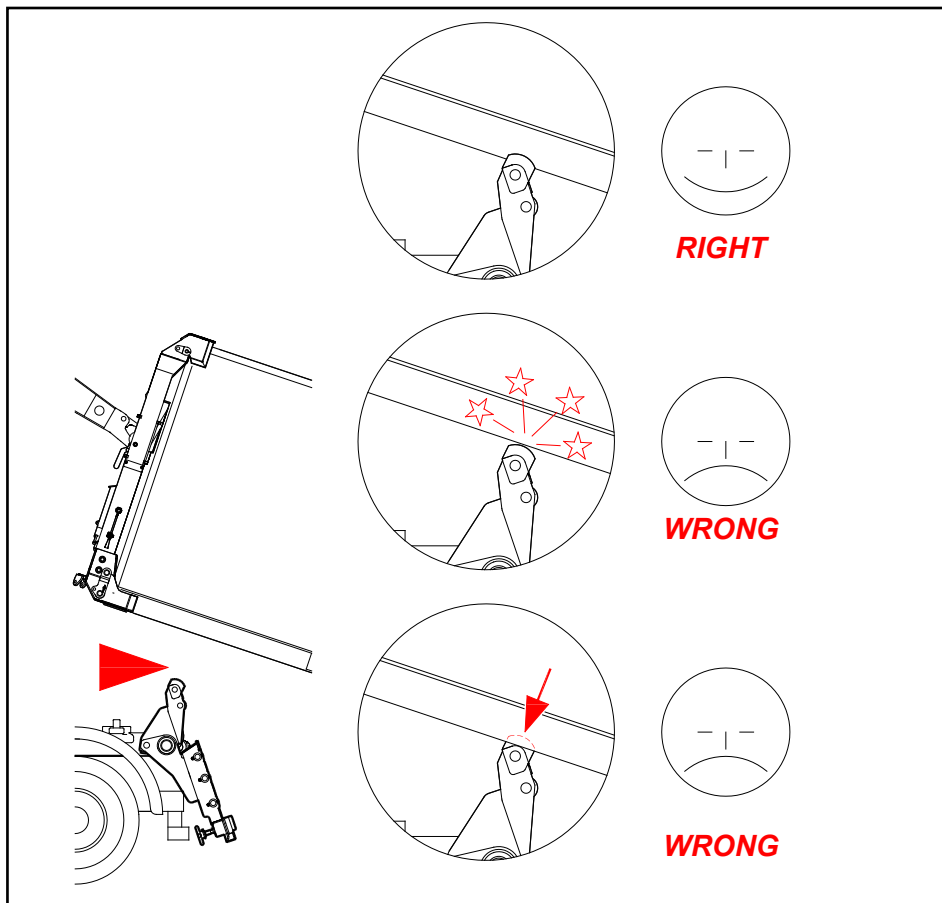

The side of the ISO container **must descend** between the rear roller control flanges. If the front of the container collides too soon with the rear rollers during loading even on even ground, the XR21S equipment's approach switches must be readjusted.



Release the handbrake as soon as the front of the container is lifted off the ground.

Please note the following as the ISO container is lifted onto the support rollers.

Make sure that the sides of the container are guided between the control flanges of the rear rollers. See the pictures on the previous page!



If either side tries to descend on top of a flange or the other flange tries to go inside the side profile of the container, the container must be lifted again by going into manual mode in between.

When the handbrake is released, the truck moving due to the strength of the XR21S equipment can be steered while the end of the container still rests on the ground.

A lightly loaded ISO container can under normal conditions be loaded in Automatic mode A1.

NOTE! When loading a heavily loaded ISO container from a difficult position, driving the hook in the middle of the operation can only be done in Manual mode A5.

Damaging the container can be prevented by lifting it with the hook frame.

See image 15A.

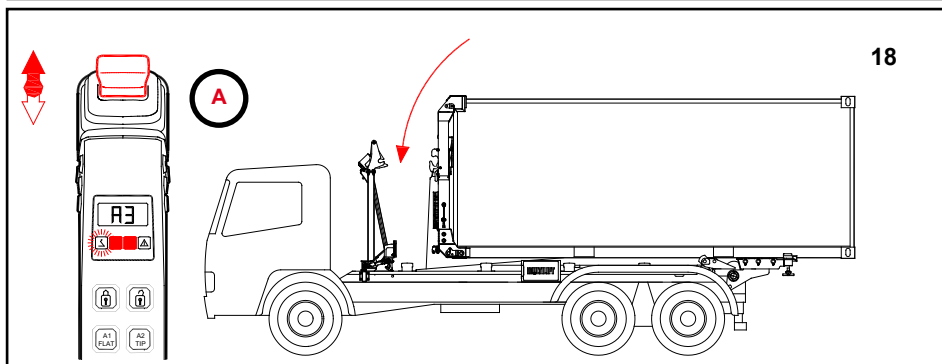
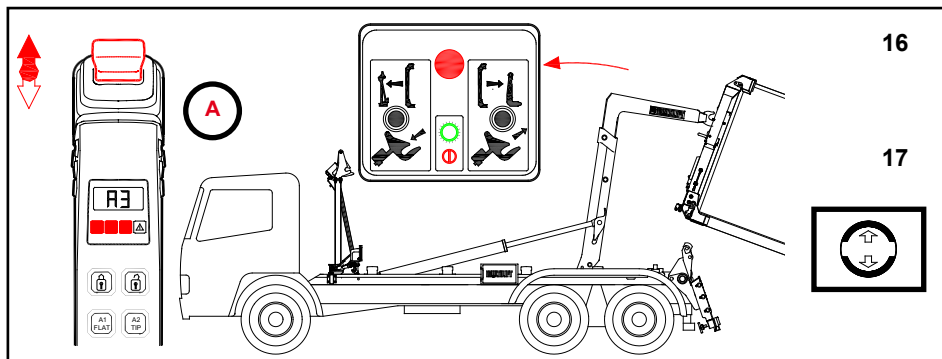
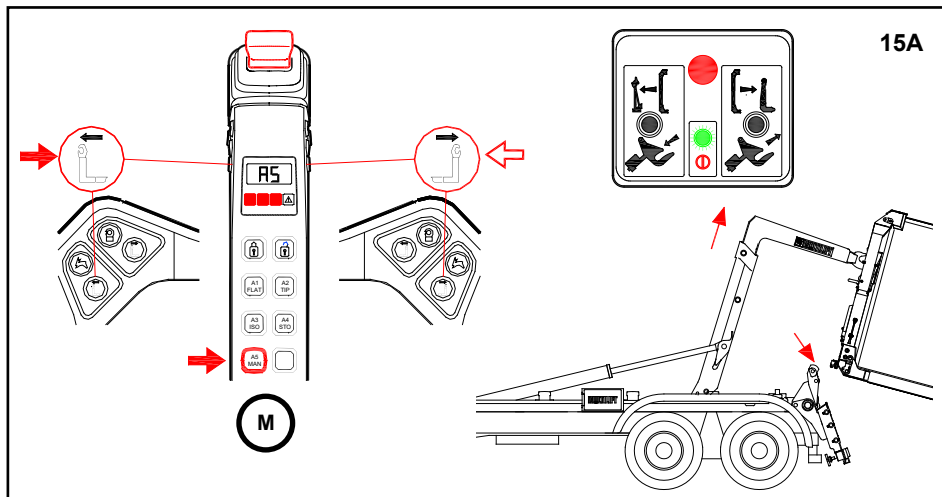

M

15A. Driving the hook frame during loading

(only in manual mode A5).

Choose manual mode A5, push the A5 button for approx. 2 s.

- green signal light "power on" is lit on the stowage control unit.

Drive the horizontal movement cylinder out

- by pushing the front button in the bottom row on the either side of the control unit.

Release the button when the front of the container is high enough off the ground not to collide too early with the rear rollers.

A

*Continue loading the container in **automatic mode A3** after lifting it.
If you performed phase 15A, please choose automatic mode A3 again
- "power on" signal light on the stowage control unit goes out.*

A

16. Middle frame forward

- move the control lever to front position
- the main cylinder piston rods move inwards.

17. Activate the handbrake when the rear end of the container is lifted from the ground.

When the container is safely on the rear rollers, load the entire container onto the frame.

18. Middle frame forward (end of the movement),

- keep the control lever in front
- main cylinder piston rods move inwards.

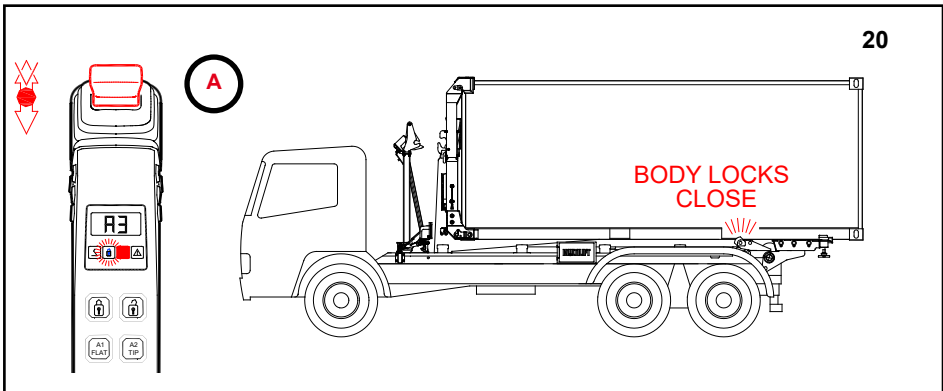
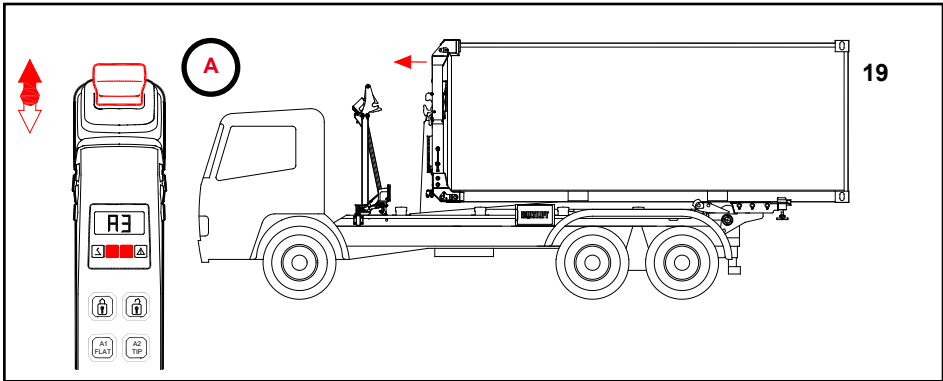

A

19. **Horizontal movement forward**

- keep the control lever in front position
- main cylinder piston rods move out
- horizontal movement comes to the container home position (that the corner locks at the back end of the ISO container meet the TWIST LOCKS at the back end of the ISO container support rollers).

20. **Closing body locks**

The movements have followed each other successively, by holding the control lever in the front.

- body locks close when the control lever is released
(ISO container is not locked with body locks, locking it is explained in section 24)
- the "locks not closed" signal light on the control unit goes out.

See chapter **Loading a flatrack/body**, sections 18, 19 and 20.



Please note that the body locks do not lock the ISO container to the XR21S equipment, see locking instruction in section 24.



Note!

When the middle frame is coming down to floating area, there is a risk that the rear frame jumps up. If this happens the system stops and "d012" can be seen in the display. Move the sliding arm slowly more forwards or backwards to get the rear frame down.

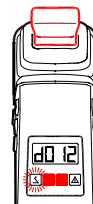

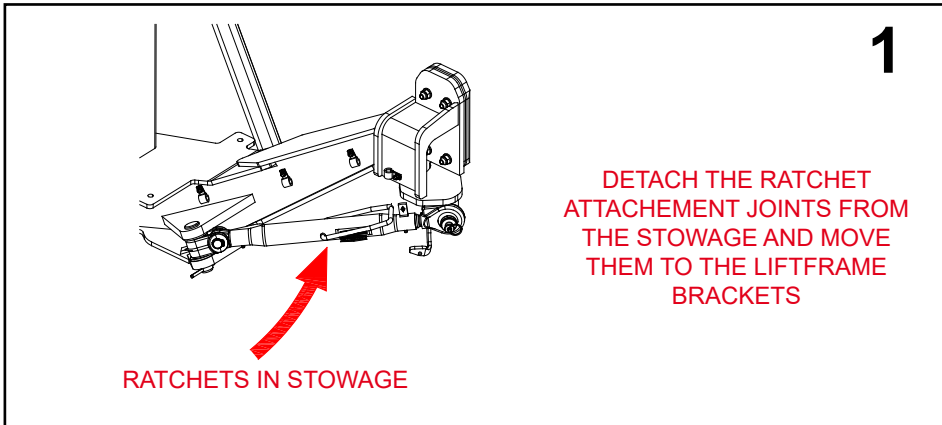
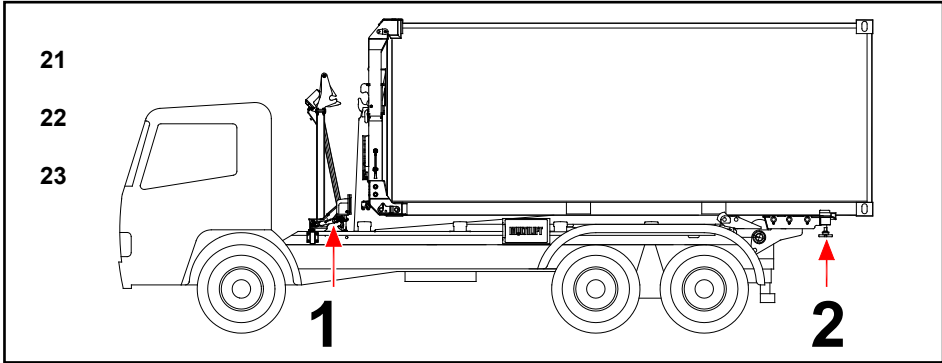

21. **Shut off the oil supply of the hydraulic pump.**
22. **Check that all signal lights of the control unit have gone out.**

During transport of ISO-containers the lift frame must always be locked at the front by the 2 ratchets mounted to the stowage. Because an ISO-container locked at all four corner castings is limiting the flexibility of the chassis, and can cause high stresses in ratchets and twistlocks, off road driving with an ISO-container must be performed at low speed.

23. Locking a container to the XR21S equipment (must ALWAYS be locked before driving)

1. In the front the container is attached by adjustable ratchets in the lifframe.

Detach the ratchet ends from the stowage and attach them to the attachment brackets on both sides of the lifframe with the shafts there. Push the shafts into the brackets from the sub frame side and put the linch pins in from the outside. The length of the ratchets can be adjusted by rotating the middle section with internal threads enough for the pins in the ratchet attachment joints to go into place. Prevent the free end of the ratchet from rotating along with the middle section. Tighten the middle sections of the container ratchets by rotating them while the ends are attached to the attachment joints.

If the container was loaded on uneven ground, drive the truck **carefully** to even ground and if necessary, center the front of the container by tightening the ratchets.

2. Tighten the back of the container with TWISTLOCKS.
Push the tightening wheel of the locks upwards, so that the clasp is pushed into the corner box of the container. When the tightening wheel is turned clockwise, the clasp first turns into a horizontal position and then as the wheel is turned more, engages the lock.

Unloading phases

XR21S EQUIPMENT IS IN TRANSPORT POSITION WHEN STARTING MOVEMENTS

Unloading an ISO container

An ISO container can be unloaded in **automatic mode A3**, because the length of IC and ICC ISO containers (6058 mm) doesn't require movements in manual mode outside a safe working area.

Only if the ISO container has a **heavy load (more than 10 t) or its floor is extended**, should the beginning of unloading be done in **manual mode A5** in order to prevent the extended container floor from scraping against the XR21S equipment body.

The first phases of unloading a heavy ISO container are depicted on the following pages.

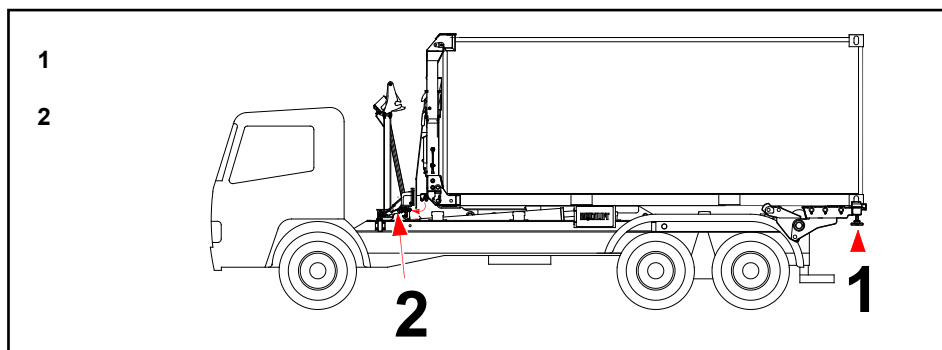

Opening ISO container locks

1. The container is locked in the back with TWISTLOCKS. Open these **first**. Rotate the tightening wheel counter clockwise. Rotating first loosens the locks and finally the clasp is turned 90° into lengthwise position and it may be released from the container corner box.
2. The front of the container is attached with ratchets from the liftframe to the XR21S equipment stowage. Open these locks **after** the TWISTLOCKS.

First rotate the middle sections of the ratchets enough to loosen them. Detach the ratchet shafts from the attachment brackets on the liftframe from both sides of the truck. Attach the ratchets to fastening pins on the inner sides of the lower sides of the stowage with lynch pins.

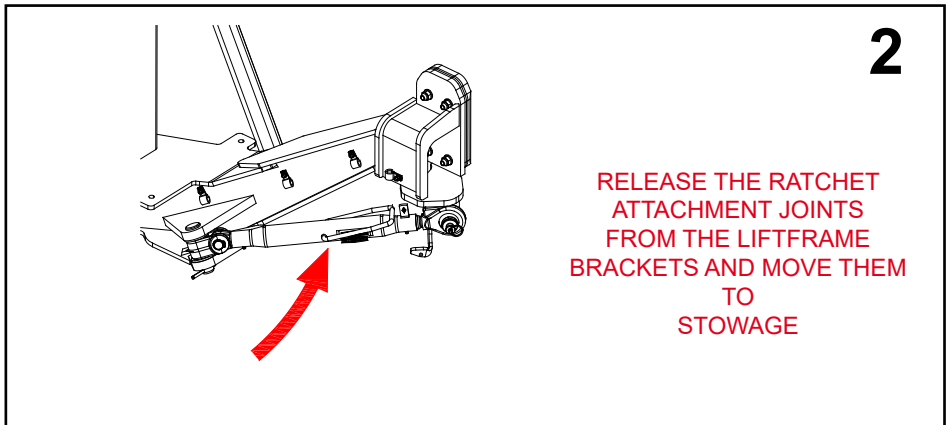

Unloading an ISO container

Follow the instructions in this manual, section **Unloading a flatrack/body**, which deal with unloading in **automatic mode A1**, when unloading an empty container, or one with a light load from the XR21S equipment.

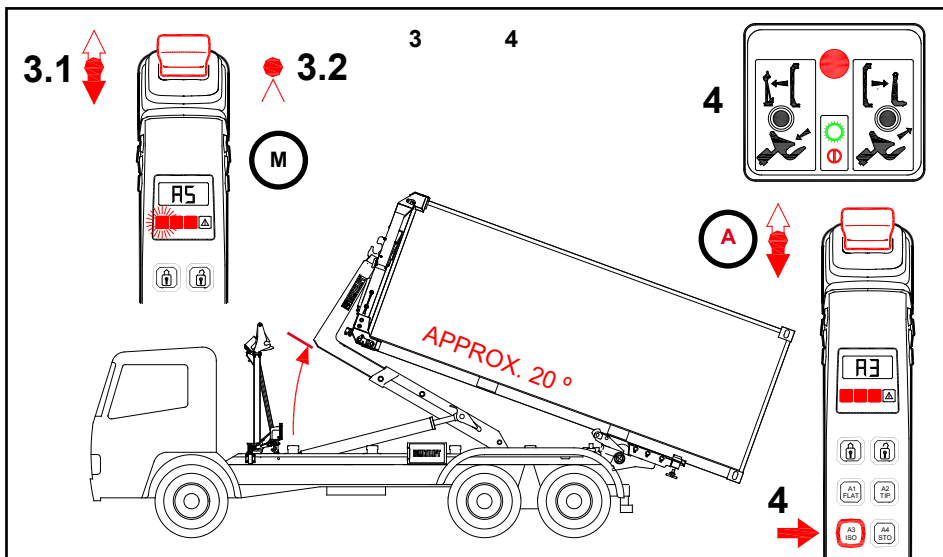
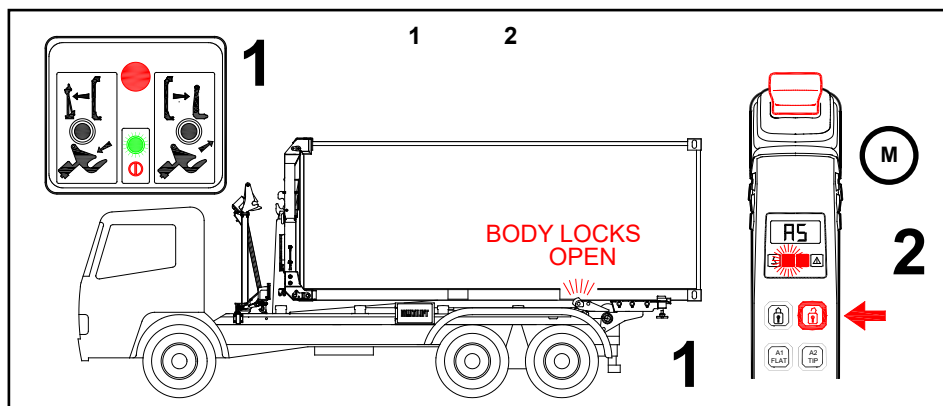

If the ISO container has a heavy load (more than 10 t) or its floor is extended, the beginning of unloading should be done according to the following sections in **manual mode A5**.

M

UNLOADING A HEAVY CONTAINER IN MANUAL MODE A5

1. **Choose manual mode A5**, push the A5 button for approx. 2 s.
 - green signal light "power on" is lit on the stowage control unit.

M

2. **Open the body locks**
 - push the "bodylocks open" button
 - "locks not closed" signal light on the control unit is lit, when the locks are fully open.

M

3. **Drive the middle frame to an approx. 20 degree angle**
 - 3.1 - move the control lever back (main cylinders out)
 - "frame not down" signal light is lit when the middle frame is lifted off the sub frame
 - 3.2 - stop the movement by releasing the control lever.

A

Changing to automatic mode A3

4. **Select automatic mode A3**
 - push the A3 button approx 2 s.
 - "power on" signal light on the stowage control unit goes out.

*When the control lever is moved back, first the XR21S equipment moves the horizontal movement backwards and the middle frame moves back, just as depicted in section **Unloading a flatrack/body** describing **automatic mode A1**.*

Detaching from an ISO container

If you intend to leave the liftrframe attached to the ISO container, detach from the container according to the description in section **Unloading a flatrack/body**.

Note: Hook lock can't be opened in **A3 automatic mode**.
Use **A5 manual mode** to open the hook lock.

If you intend to detach the liftrframe from the ISO container and take it elsewhere, don't press the safety lock control button as the container reached the ground, but continue according to the next step.

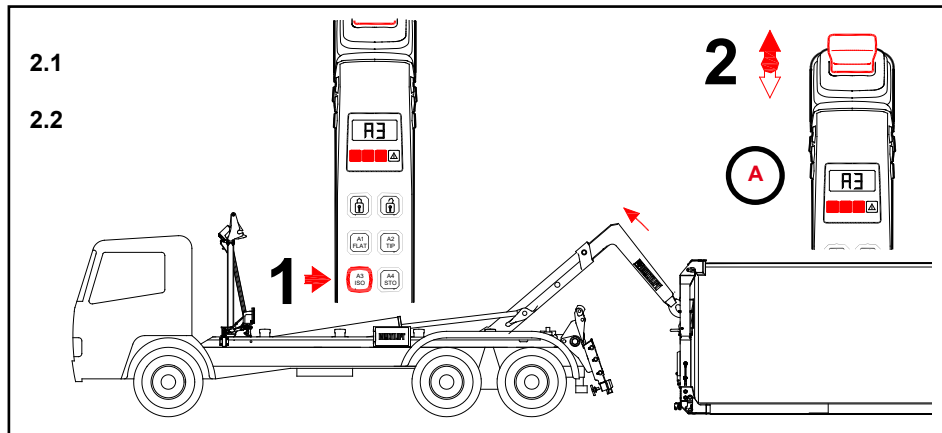
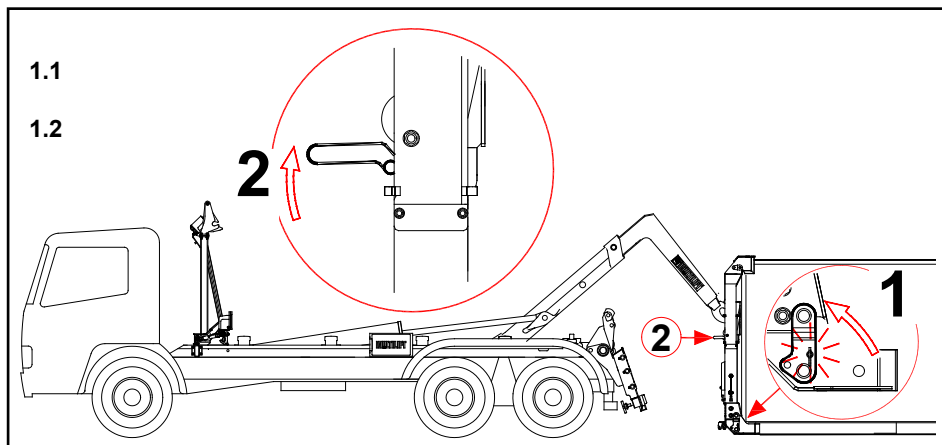

Releasing the liffframe from the ISO container

LIFFFRAME ATTACHED TO AN ISO CONTAINER DURING UNLOADING WHEN STARTING MOVEMENTS

Let the engine run at idle speed during stowage movements.



NOTE!

Unnecessary use of the main pressure relief valve should be avoided, because it may overheat the oil.

1. Opening the locking shafts on the lower corners and lock grips on the upper parts of the liffframe

1. Release the lower liffframe corners from the ISO container by extracting the locking shafts using the crowbar if necessary.

Turn the shafts on both sides of the equipment to 90° upward, and fasten them again to the body, the locking plates in a **STOWED position**.

2. Turn the lock grips on the telescopic upper parts of the liffframe back to **open position** (grips horizontally).

A

2. *Lifting the upper part of the liffframe from a container*

PHASES SHOULD BE CARRIED OUT IN AUTOMATIC MODE A3

1. **Select automatic mode A3**
 - push the A3 button approx 2 s.
2. **Small movement middle frame forward**
 - "locks not closed", "URB" and "frame not down" signal lights on the control unit are lit
 - move the control lever momentarily to the front.

Drive the middle frame a little bit forward, in order to lift the liffframe from the ISO container corner boxes.

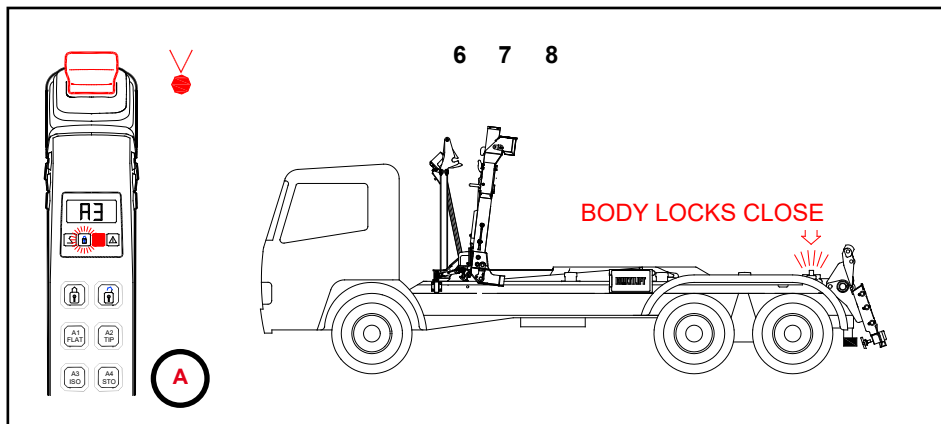
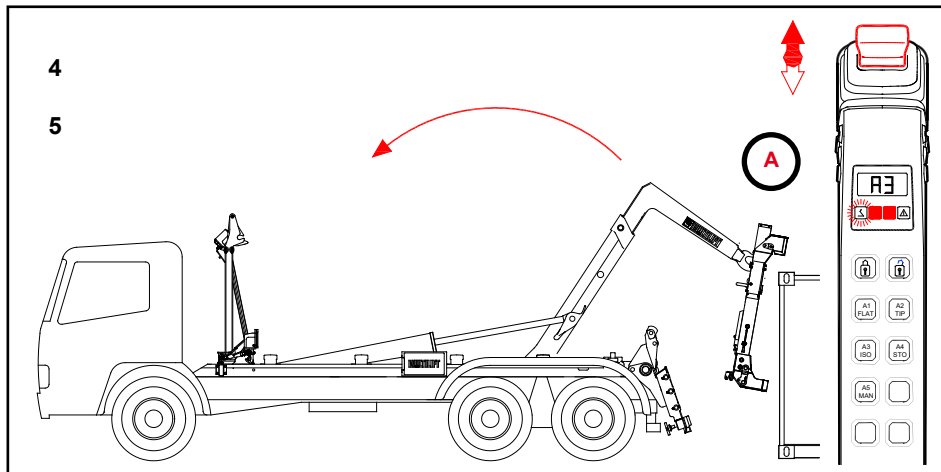
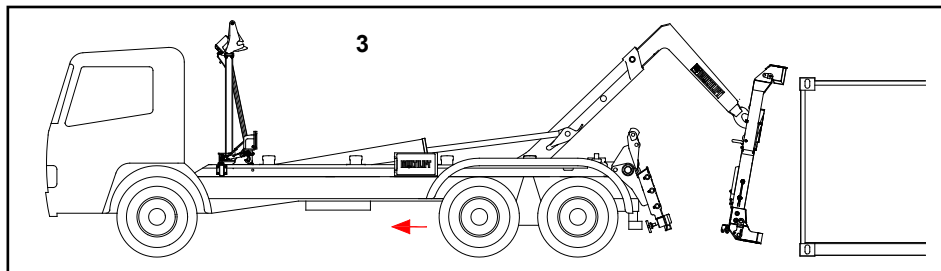

A

3. **Drive the truck a little forward so that the lifftframe comes free from the ISO container.**

 4. **Middle frame forward**
 - drive the middle frame forward by holding the control lever in the front (main cylinders in)
 - "frame not down" signal light on the control unit goes out, when the middle frame comes down.

 5. **Horizontal movement forward**
 - drive the middle frame forward by holding the control lever in the front
 - horizontal movement comes to the front position of container change (approx. 350 mm from the far-front position of horizontal movement).

 6. **Closing body and tipping locks**
 - logic closes the body and tipping locks automatically as the control unit is released at the end of the horizontal movement.
 - when the locks are engaged fully, their signal light will go out.
-
7. **Shut off the oil supply of the hydraulic pump.**
 8. **Check that all signal lights of the control unit have gone out.**

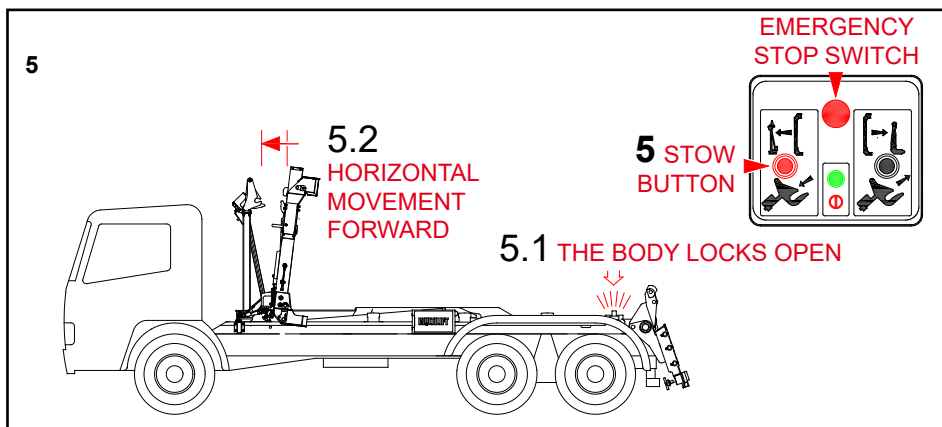
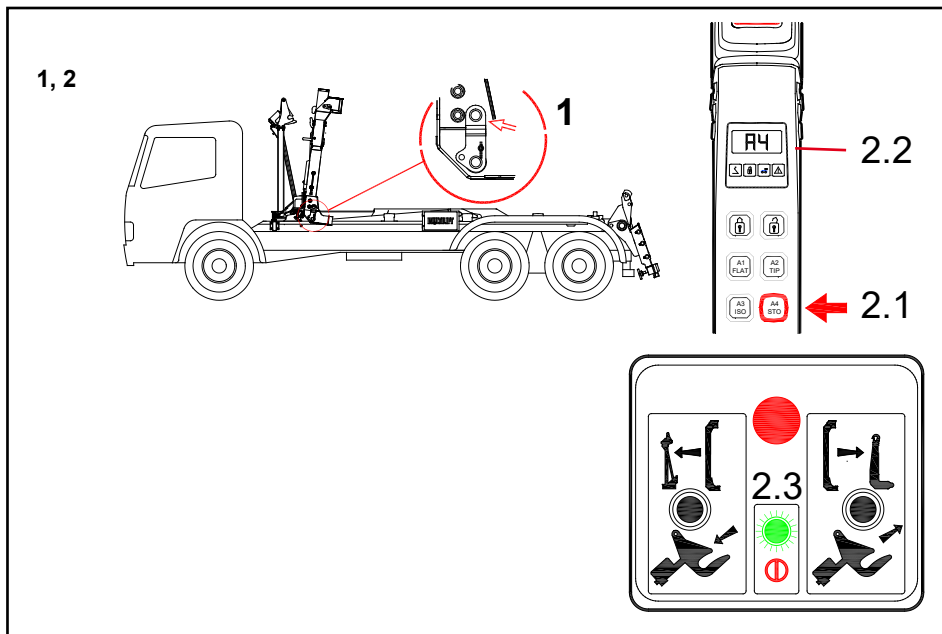

Moving the liftframe onto the XR21S stowage

MIDDLE FRAME OF THE XR21S EQUIPMENT RESTS ON THE SUB FRAME AND THE LIFTFRAME IS IN THE GRIPPING HOOK WHEN STARTING MOVEMENTS

It is recommended to let the engine run idle during the stowage movements.

1. **Check and, if necessary, push the locking shafts on the lower parts of the liftframe to the STOWED position.**
2. **Engaging the stowage mode A4**

Choose mode A4

- 2.1 push the A4 button shortly
- 2.2 code "A4" is lit on the XR21S equipment control unit display
- 2.3 green signal light "power on" is lit on the stowage control unit.

If it seems impossible to select the mode and code "d019" is displayed on the control unit, make sure that the attachment joints of the liftframe ratchets are attached to the stowage.

3. **Activate the handbrake.**
4. **Engage the hydraulic pump.**
5. **Moving the liftframe from the XR21S -gripping hook to the stowage**

Code "A4" is visible on the XR21S equipment control unit display.
Green signal light "power on" on the stowage control unit is lit.

Press the STOW button on the stowage control unit without releasing it:

- 5.1 **Body locks open** if they are still closed.
- 5.2 **Horizontal movement moves to the stow/unstow position**
horizontal movement stops in its far-front position.

>>>

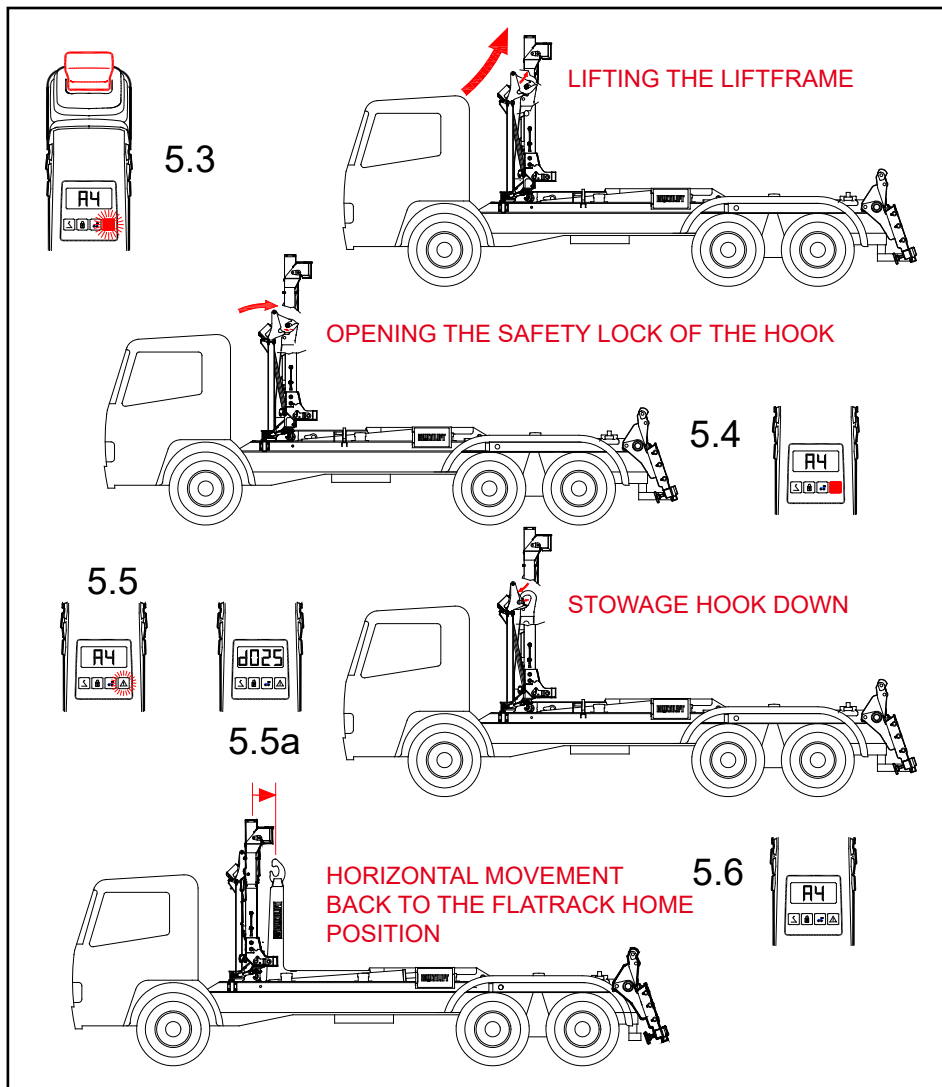

>>>



The safety lock of the XR21S gripping hook is in open position during stowage movements, which may cause the frame to fall off if the stowage bumps into the lifftframe.

5.3 **Lifting the lifftframe from the XR21S gripping hook**

The stowage actuator turns the stowage hook up and lifts the lifftframe to the top of the XR21S gripping hook opening

5.4 **Opening the safety lock of the XR21S gripping hook**

The lifftframe comes free of the XR21S gripping hook

5.5 **The stowage hook turning downwards**

The stowage actuator turns its hook down and brings the lifftframe onto the stowage.

The safety lock of the XR21S gripping hook closes as the STOW button is released.

5.5a Code "d025" is displayed if "Stowage in" sensor is active, but "Lift Frame Stowed" sensor is not active.

It will also prevent sliding backwards movement.

5.6 **The horizontal movement goes back to the container changing position**

horizontal movement goes to the front position of container change (approx. 350 mm from the far-front position of horizontal movement).

6. **Shut off the oil supply of the hydraulic pump.**

7. **Check that all signal lights of the control unit have gone out.**

Locking the liftframe to the stowage

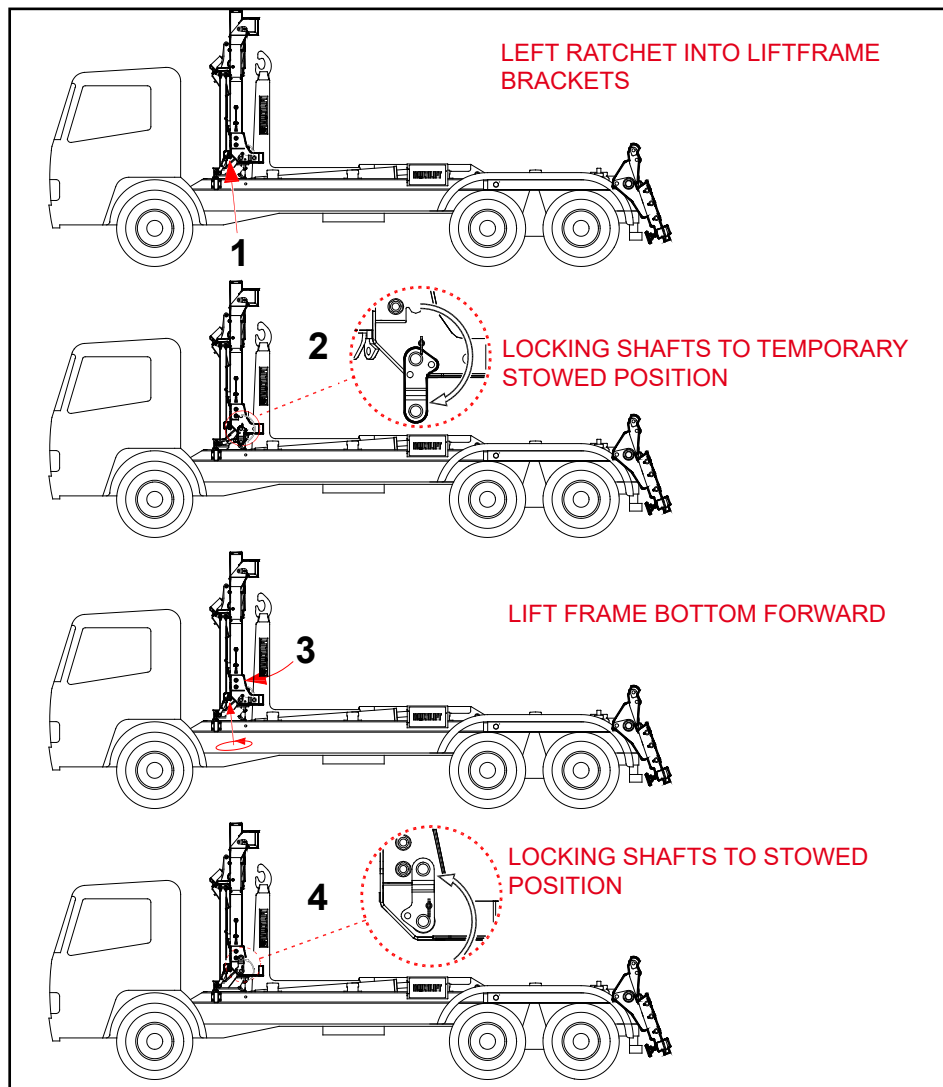

1. Attach the left ratchet to the lifftframe.
2. Extract the locking shafts on the lower parts of the lifftframe using the crowbar if necessary. Turn the axis on both sides of the equipment to 180° **temporary STOWED position** (lock plates vertical), **note** leave the whole pin extracted so the lifftframe can move in front of the stowage.
3. Move the bottom part of the lifftframe forward while controlling it with the LH ratchet.
4. Turn the locking shafts on the bottom parts of the lifftframe to their **STOWED position** (lock plates vertical).
5. Attach the right ratchet to the lifftframe. Move the bottom part of the lifftframe forward, if needed and fasten both ratchets.

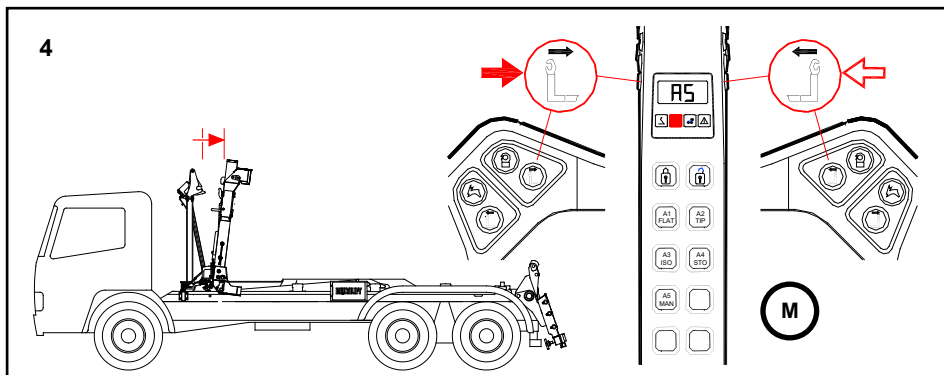
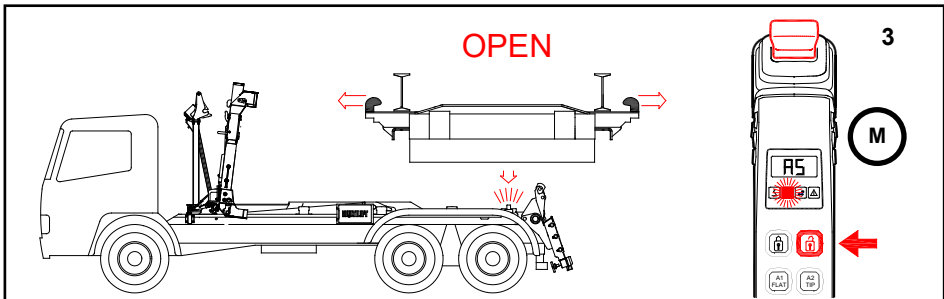
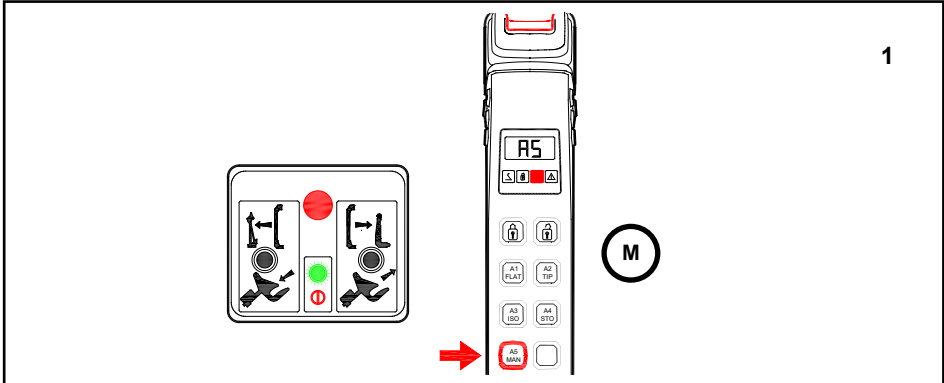

Removing the liftframe from XR21S gripping hook and leaving it on stand supports

LIFTFRAME HANGING FROM THE XR21S GRIPPING HOOK WHEN STARTING THE PHASE

1. Drive the truck to the intended parking area.



The liftframe stand supports are not meant to be used on uneven ground: a lifting frame laid on the supports may fall over and cause damage.

M

MANUAL MODE A5

1. **Choose manual mode A5**
 - push the A5 button for approx. 2 s
 - green signal light "power on" is lit on the stowage control unit.

2. **Activate the hydraulic pump.**

M

3. **Open the body locks**
 - push the "bodylocks open" button
 - "locks not closed" signal light on the control unit is lit, when the locks are fully open.

M

4. **Drive the horizontal movement cylinder in**
 - push the rearmost button in the bottom row on the either side of the control unit, until the horizontal movement goes to the ISO container home position (approx. 350 mm from the stow/unstow position of horizontal movement).
 - mechanical tipping lock opens when the hook frame is in rear position.

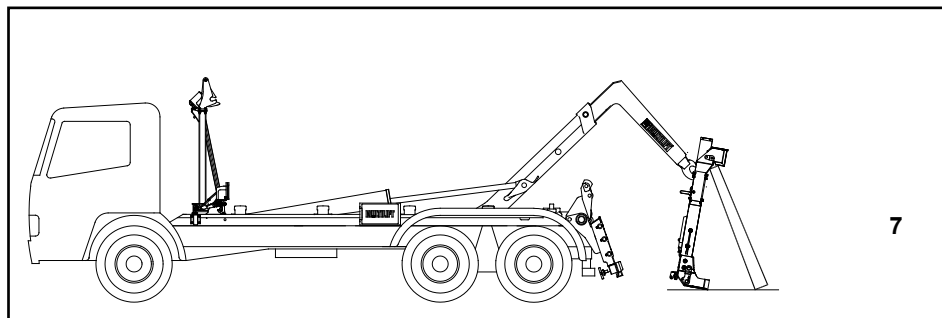
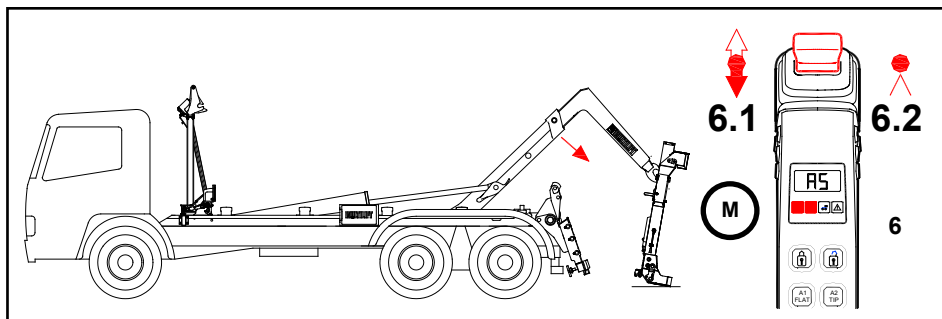
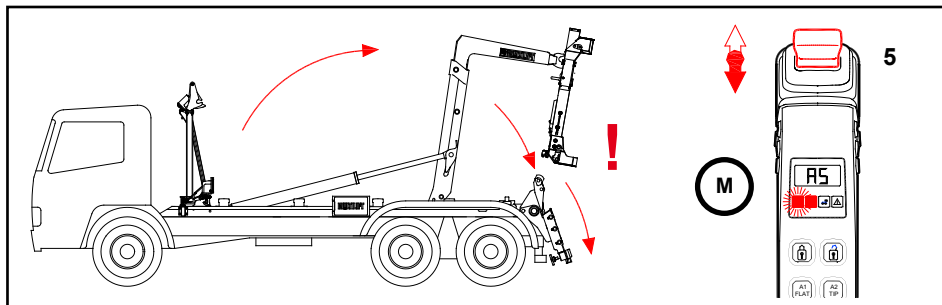

M

5. **Drive the middle frame back**

- drive the middle frame back by moving the control lever back (main cylinders out).
- "frame not down" signal light is lit, when the middle frame is lifted off the subframe.



Monitor the lower ends of the liftframe during the movement. If the body is in danger of colliding with the rear rollers, stop the movement before colliding and drive the horizontal movement upwards.

M

6. **Lowering the liftframe to the ground**

- 6.1 - continue the movement until the lower corners of the liftframe touch the ground
- 6.2 - stop the movement by releasing the control lever.

6. **Supporting the liftframe**

Support the liftframe using heavy wooden or metal supports!



MAKE SURE THAT THE GROUND IS FIRM! A liftframe support sinking may cause the frame to fall over. If necessary, place e.g. a piece of plank under the support.

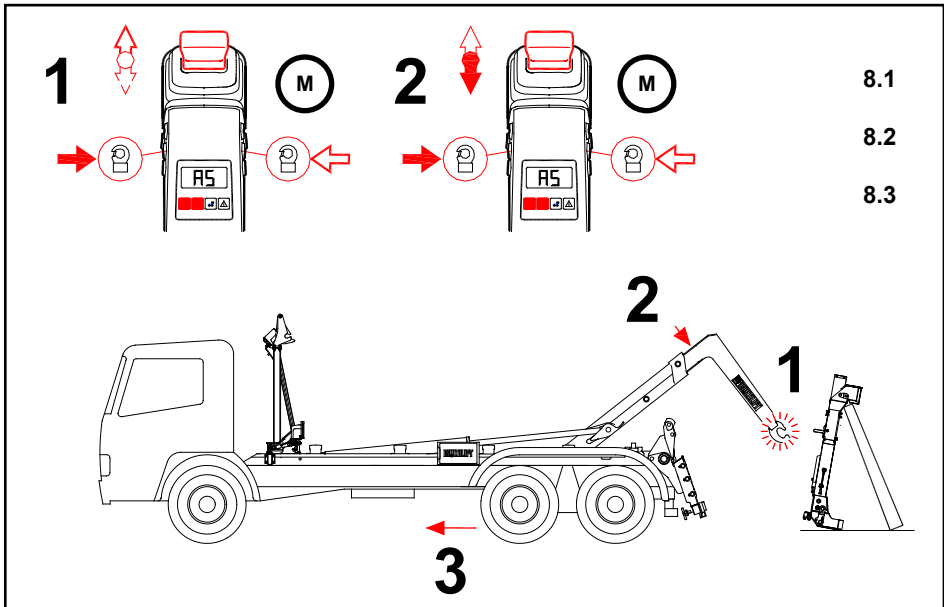



**No maintenance work may be carried out
on a liftframe supported by stand supports!**

M

8. Free from the liftframe

Manual mode A5 is selected.

8.1. Open the hook safety lock by pressing its release button.

Make sure that the lock opens.

If it doesn't lift the middle frame slightly by moving the control lever forward. Open the safety lock.

8.2. Keep the safety lock button pressed and drive the middle frame slightly backwards by moving the control lever backwards. Monitor the hook being released from the gripping bar on the liftframe.

DO NOT TIP THE LIFTFRAME OVER!

8.3. Drive the truck forward if the hook has been released from the gripping bar.

Release the safety lock button. The lock will close in 10 s. Activate the handbrake.

M

9. Middle frame forward

- drive the middle frame forward by holding the control lever in the front (main cylinders in)
- “frame not down” signal light on the control unit goes out, when the middle frame comes down.

10. Horizontal movement forward

- drive the horizontal movement forward by pushing the front button in the bottom row on the either side of the control unit (telescope cylinder out)
- horizontal movement comes to the flatrack home position (approx. 350 mm from the stow/unstow position of horizontal movement).

11. Closing body and tipping locks

- logic closes the body and tipping locks automatically as the control unit is released at the end of the horizontal movement
- when the locks are engaged fully, their signal light will go out.

12. Shut off the oil supply of the hydraulic pump.

13. Check that all signal lights of the control unit have gone out.

You are now ready to pick up your next container.



**Always drive in traffic with the middle frame
lowered onto the sub frame.**



Tipping an ISO container IS NOT allowed!

**THE XR21S REAR ROLLERS WERE NOT DESIGNED FOR
TIPPING AN ISO CONTAINER.**

**THE ISO CONTAINER SUPPORT ROLLER AXIS AND THE XR21S
TIPPING AXIS ARE NOT IN LINE WITH EACH OTHER. AS A RESULT, TIPPING IS
NOT POSSIBLE.**

Design description

Technical specifications

Hooklift XR21S

Manufacturer Multilift, Raisio

Equipment type

Technical performance, flatrack/body max (t)

Technical performance, ISO container max (t)

Tipping angle, max (°)

Working pressure of the hydr. system, max (MPa (bar))

Recommended oil flow rate (l/min)

Operating times with oil flow rate X, G = 56 X (l/min)

- loading (approx.) (s)

- unloading (approx.) (s)

- tipping (approx.) (s)

- lowering the flatrack/body after tipping (approx.) (s)

Weight of the assembled equipment

XR21S
21
16
46 - 53
30 (300)
100
100
45 / 35
55 / 40
50 / 40
40 / 30
XR21S56: 3315 kg XR21S59: 3345 kg

XR21S dimensions

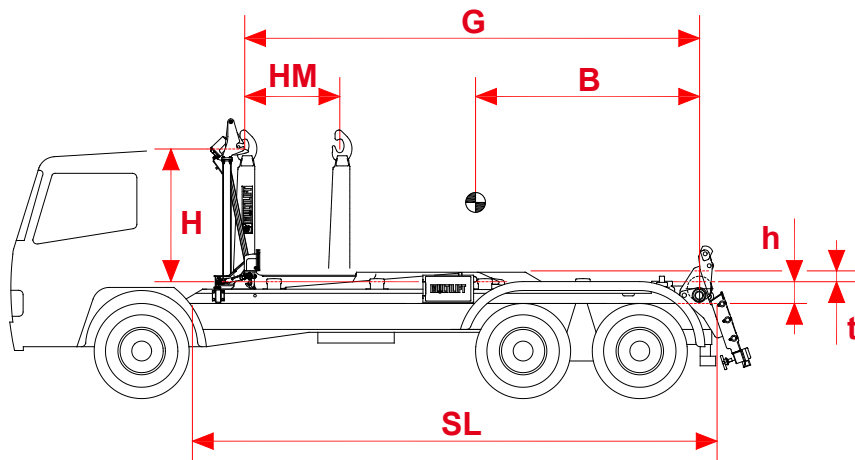

	XR21S56	XR21S59
G (mm)	5560	5860
h (mm)	270	
H (mm)	1570	
t (mm)	105	
B (mm)	2800	2850
SL (mm)	6563	6563



BE AWARE!

When transporting the body with the sliding frame in rear position, the hydraulic body lockings must be closed.

Construction

XR S hooklift equipment contains frames joined to each other which enable loading, unloading and tipping of compatible Flatrack/bodies. The rear frame hinged to the rear end of the sub-frame, which is fastened to the truck chassis, enables tipping of the Flatrack/bodies (note: ISO Containers must never be tipped). The middle frame hinged to the rear frame together with the hook arm sliding inside it, enable container loading and unloading.

Hydraulics

The configuration of the hooklift control valve comprises on the base plate situating, electrically controlled directional valves, which distribute the oil flow to different cylinders. There is one control valve for the hook arm and the locking cylinders and two for the main cylinders. The main cylinder control valves operate at phases, depending on the accessories, or at the same time and enable thus a more accurate control at slow speeds and greater oil flow for simultaneous use.

There is a by-pass valve installed on the valve base plate, which is adjustable between 16 and 40 l/min. With this valve part of the oil flow is directed via the second valve of the main cylinders back to the return line, and that is the way to obtain the accurate cylinder movements when needed. The factory setting of the by-pass valve is 28 l/min. By turning the valve close or open it is possible to obtain a slower motion of the main cylinder and to adjust the speed of the hook arm cylinder.

The electrically controlled solenoid valve opens the free circulation flow, when no cylinder movement is active.

The setting of the main pressure limiting valve is 300 bar, in addition of which the functioning of the hydraulic locks and the hook arm out push pressure is limited to 180 bar.

There is a push button in the main cylinders' first valve, the hook arm cylinder valve and free circulation valve solenoid for possible emergency operation if the electrical current of the hooklift disappears for some reason.

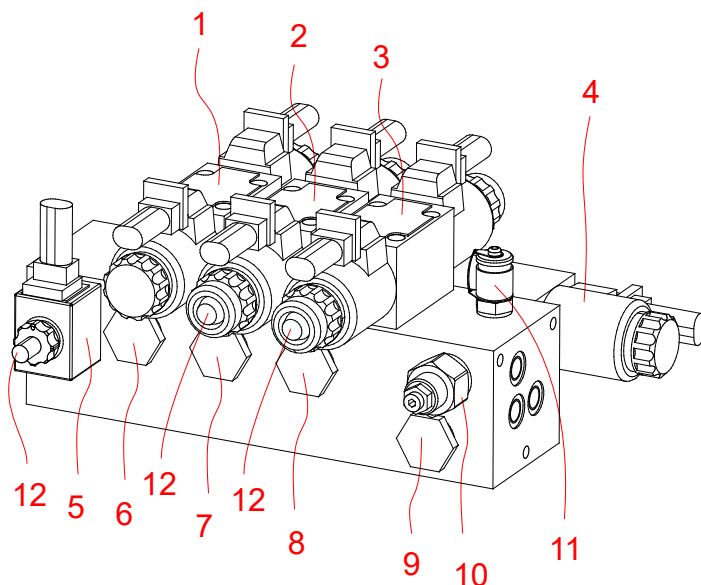

1. Container locking cylinder directional valve
2. Hook arm cylinder directional valve
3. Main cylinders' first directional valve
4. Main cylinders' second directional valve
5. Free circulation valve
6. Body locking cylinder pressure limiting valve 18 MPa
7. Body locking cylinder pressure limiting valve 18 MPa
8. Hook arm out push pressure limiting valve 18 MPa
9. Main pressure limiting valve 30 MPa
10. Adjustable by-pass valve 16 - 40 l/min
11. Pressure measuring nipple
12. Emergency operation push button

EMERGENCY OPERATION

See maintenance manual.

Control devices, 2GCC

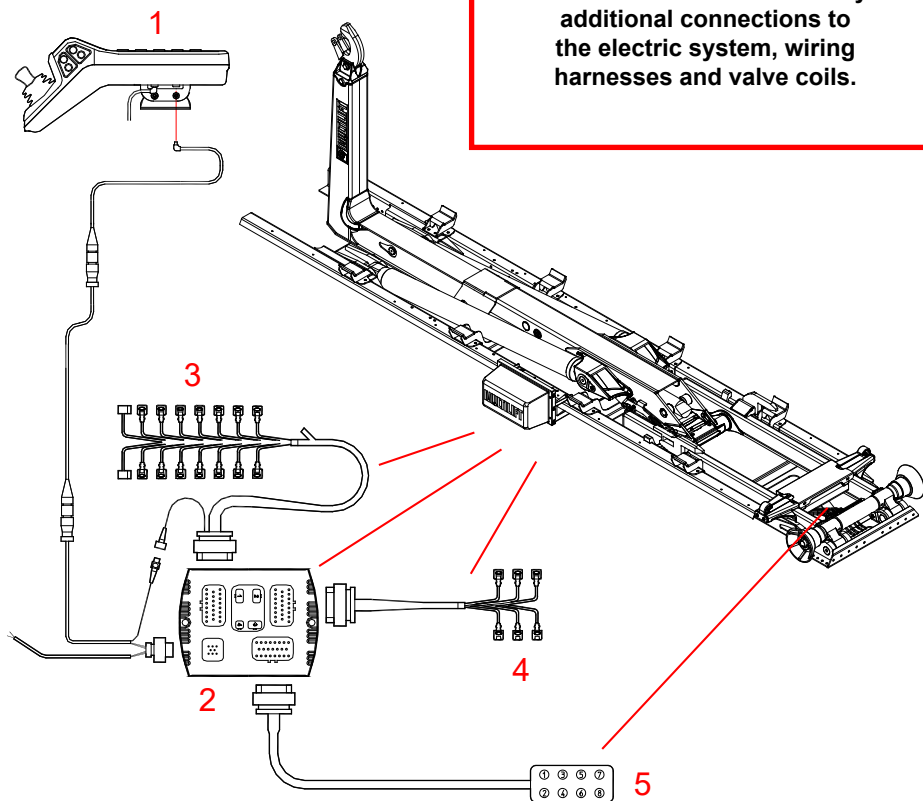

1. Control unit in the cab
2. I/O module
3. Valve wiring harness
4. Accessory wiring harness
5. Wiring harness of proximity switches

EQUIPMENT

Hook, pneumatic

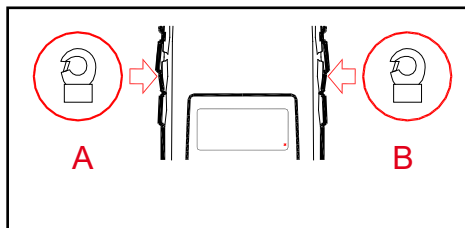

The safety lock of the gripping hook is opened by pressing the corresponding button on the control unit. Use button A or B.

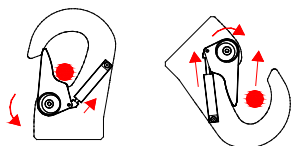

1 - 30 sec.
Delay adjustable

The safety lock remains open during 1 - 30 secs (adjustable) after the button is pressed and closes by the spring force of the pneumatic cylinder. When the safety lock is open by pneumatic force, a sound is produced by the pneumatic cylinder due to the released air. Press the button again when necessary.

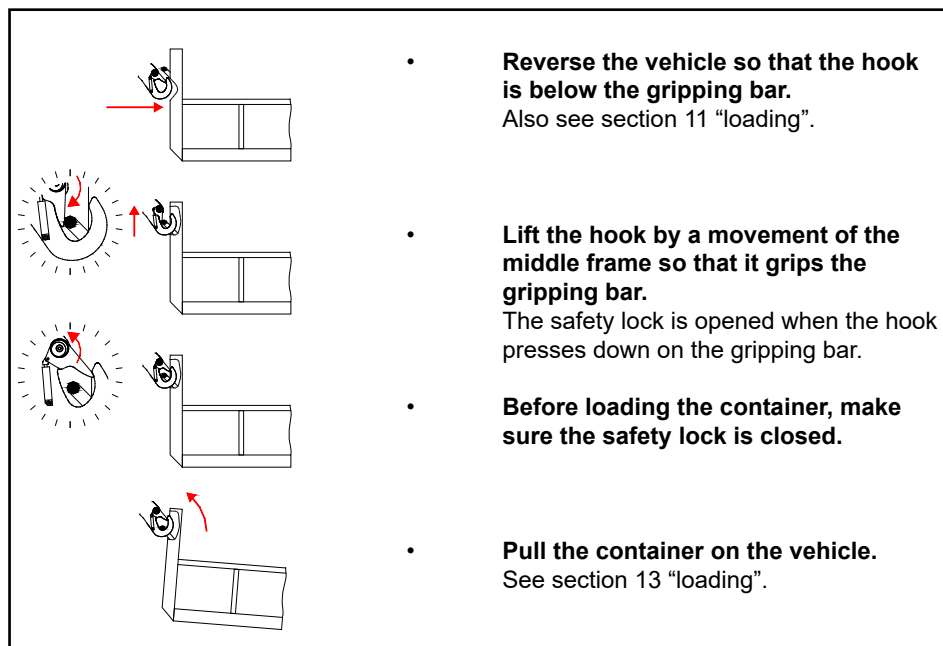

The correct operation of the safety lock must be checked regularly and the shaft nipple greased every month.

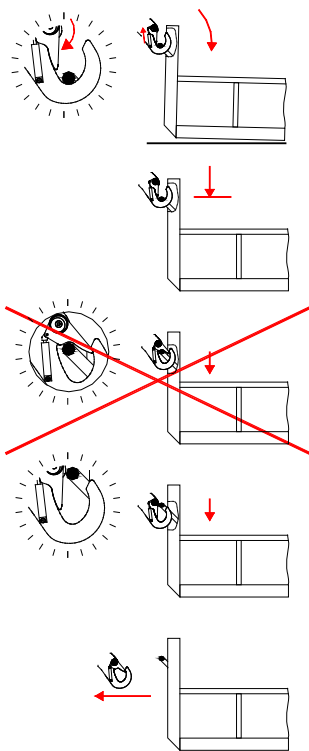
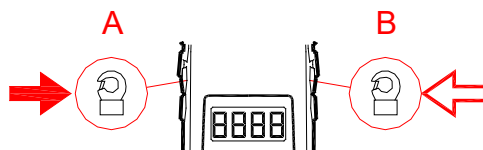

- **Open the safety lock of the gripping hook by pressing button on the control unit immediately before lowering the front end of the container to the ground.**
- **Stop the main cylinder when the container reaches the ground.**
- Check that the safety lock is still open. **If the safety lock has closed, it may cause the safety lock or the gripping bar to be damaged when the hook is pressed down on the gripping bar.**
- **Continue the downward motion of the main cylinders, with the safety lock open, until the hook is released from the gripping bar.**
- **Drive the vehicle forward, away from the container.**
See section 12 "unloading".

Locking mechanisms of the hook

For safety reasons, the tipping, loading and unloading operations are secured with various locking mechanisms between the frames of the equipment. The container is frontally locked to the equipment by a gripping hook and by means of hydraulic and/or mechanic locks in the rear end.

Tipping lock

Mechanical tipping lock (locking rear frame to middle frame)

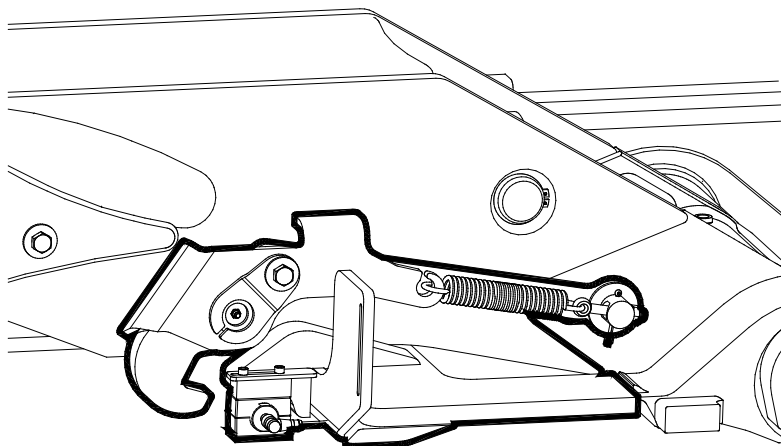

The mechanical tipping lock is situated between the rear frame and the middle frame and consists of hooks that lock on to lugs. The hooks cannot lock on when the hook arm is in the rear position. They automatically lock on when the hook arm moves forward more than 100 mm. Tipping is not possible when the hook arm is all the way back. During tipping, the middle frame is locked to the rear frame by the tipping lock. The tipping lock operates automatically according to the movements of the hook arm.

Rear frame lock (locking rear frame to auxiliary frame)

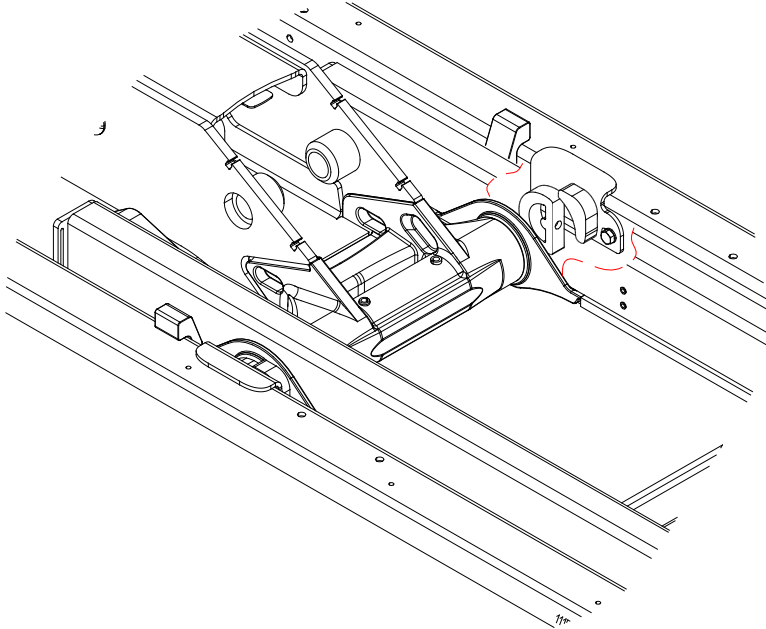

During the lowering of a container, the rear frame is mechanically locked to the auxiliary frame when the middle frame starts to rise. The lock is achieved by the axle tip on the middle frame, which slides under the locking stops in the auxiliary frame.

Container locks

Outside hydraulic locks

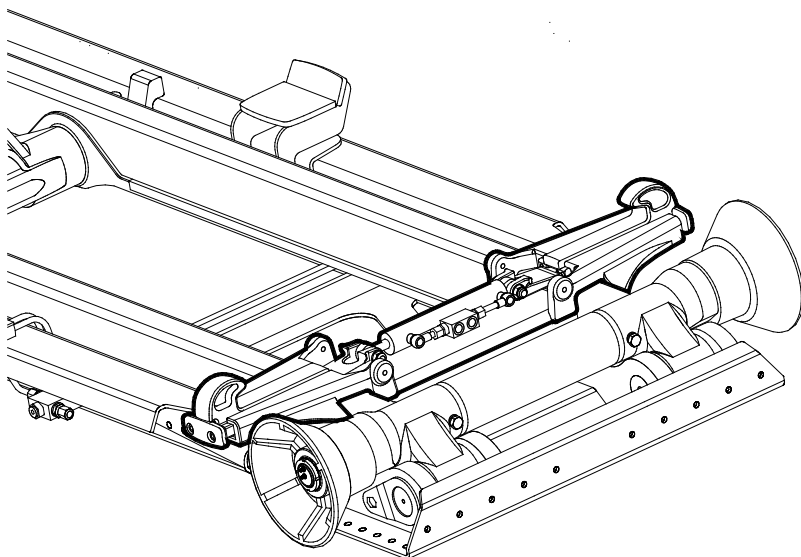



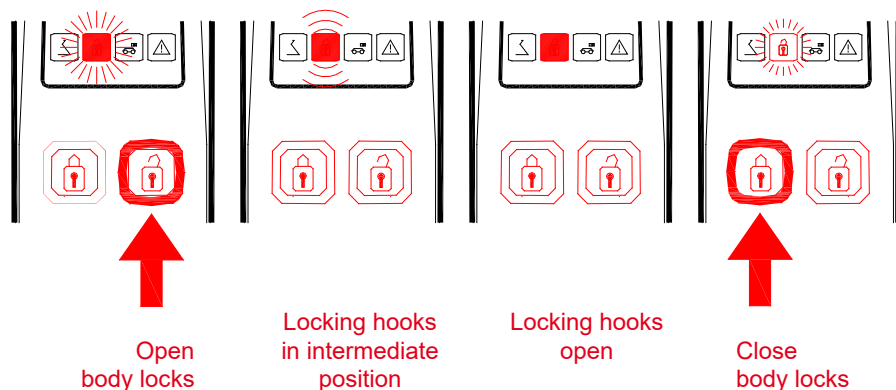

In the outside hydraulic locks, the hooks lock the container in place from the outside flange.

Each lock type is situated in the rear end of the rear frame. The locking cylinder steers both locking hooks simultaneously. A controlled check valve is fastened to the locking cylinder, preventing the cylinder from letting the locks open in case of a broken hose in the hydraulic circuit or an internal leakage in the control valve. Thanks to the valve, the flatrack/body locks stay in the intended position, open or closed.

Switch and signal light of hydraulic body locks



The body locks are opened by pressing the switch in the control unit. A illuminated lock signal light on the control unit means that the body locks are not fully closed. When in traffic, no driving or tipping is to be commenced if the light is on. Remove the element obstructing the locks, or if they are obstructed by the lock pocket in the flattrack/body frame beam, check that the flattrack/body is correctly positioned on top of the hook device.

-  Signal light comes on
-  Signal light illuminated
-  Intermittent signal light
-  Signal light goes out
-  Signal light off

Protection of main cylinder

The protection circuit of the main cylinders protects the main cylinder's piston rods from buckling. The protection circuit comprises a tilt indicator and a pressure relief valve. If the tilt is greater than set angle value, the working pressure is restricted to 11 MPa (110 bar) and the backwards movement of the container may stop.

If this does take place, check that the movement of the platform rearward is free from obstructions.

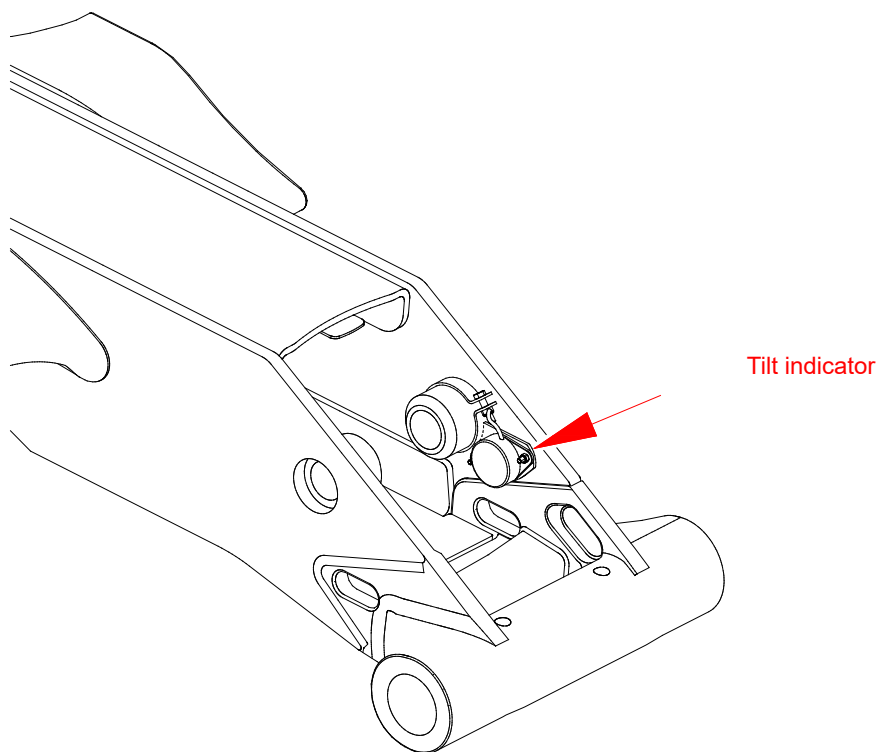

Tilt indicator

This manual is a translation from the original maintenance instructions compiled in Finnish.

MAINTENANCE

Service Indicator

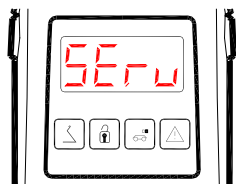

The service interval of the MULTILIFT hooklift is approximately 180 operating hours or 3,600 service cycles, depending on which limit is reached first.

The "**SERV**" notification displayed in connection with the start-up indicates imminent service. This notification is shown for approximately 30 operating hours before the service time. Contact your own HIAB service to book the service.

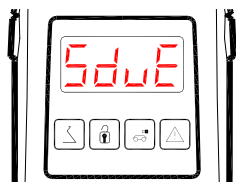

A permanent "**SDUE**" text on the display indicates immediate service. This notification is reset by an authorized HIAB service point in connection with the service.

Regular and correctly timed maintenance will increase the safety, reliability and economy of the hooklift equipment. All accomplished services and replacements of wearing parts are worth while to record.

In connection with the maintenance work, the work safety must be noted and all possible danger elements must be kept in mind by everybody participating. This instruction must be read carefully before commencing any service work.

The equipment operator can carry out the daily, weekly and monthly services described in these instructions. If there appears damages, hydraulic leaks, malfunctions or other problems with the equipment, contact the nearest Multilift service point. Repairs related to these may be carried out only by the professional and trained personnel. Especially the electrical system and the hydraulics are such which require specialised competence.

Wash the equipment carefully with low pressure washer before inspection and service. Dry and check all electrical components after washing.

Safety instructions

Loose, long hair, loose clothing, jewellery etc. are an accident risk.

Use always personal protections and other protective means in service work.

All modifications and additions made to the equipment construction, which might have an effect to the operational safety of the hooklift, are prohibited. In general, all modification and additional work on the equipment must be consulted with the dealer or manufacturer of the equipment. Also a more extensive repair work or welding work to be done on frames must be approved by an authorised service shop or the manufacturer of the equipment.

All the spare parts must conform with the technical requirements of Multilift. The best way to ensure this is to use the original Multilift spare parts.

The safe and easy accomplishment is best achieved by using the correct and sound tools.

Note the service and inspection periods mentioned in this instruction and the replacement needs of parts which have been noted in connection with the equipment inspection.

Wash and clean the equipment regularly before any service work.

Never service an equipment when the truck engine is running or the PTO is engaged.

Each service work must have a named responsible person who is responsible for the vocational skills of the person carrying out the work.

Try always to separate the service area from persons not involved.

Before water wash, cover and protect all the electric components and connections. Do not direct the washing agents to hot points.

- Inform the equipment operator of the start of the maintenance work.
- If the equipment is damaged or otherwise non-functional, ensure that it cannot be started accidentally before and especially during the service work.
- Remove the truck ignition key and keep it in a safe place. Inform also others, for example, with a warning sign.
- If there are several persons involved in the service work at the same time, the one having the ignition key must inform everybody if, for example, the truck engine is started or the hooklift functions are used.

If the work area is under the tipping frame, the equipment must be moved to loading position.

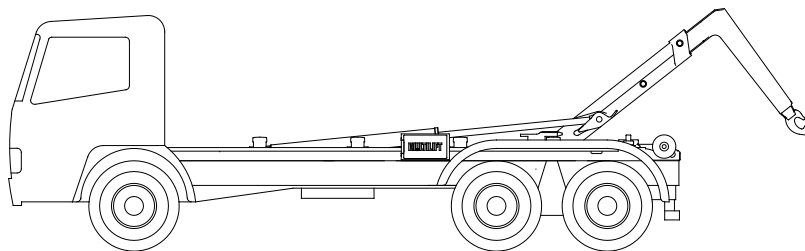

Hooklift in rear position

If the work is done under the middle frame, the equipment must be moved to loading position and the frames supported with separate tipping support in the correct places. Remember to remove the support after the work has been completed.

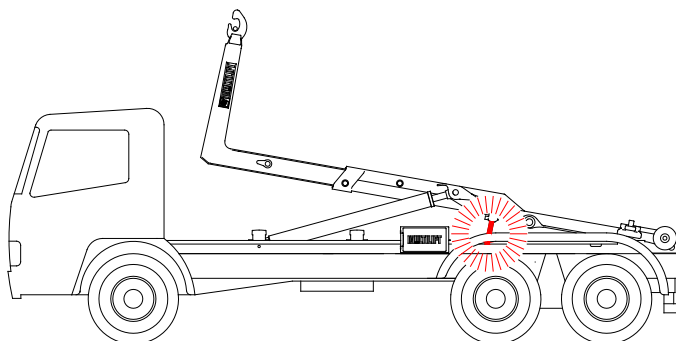

Hooklift supported to tipping position

If the work is done under the rear frame, the equipment must be lifted to tipping position and the frames supported with separate tipping support in the correct places. Remember to remove the support after the work has been completed.



BE AWARE!

Never move the middle frame or the rear frame by means of hydraulics against the tipping support. The equipment cylinders are powerful enough to break the support or the frames and there is a great risk of personal injury. Stop the movement of the main cylinders immediately when the frame reaches the support.

Stop the truck engine always when doing service work under the raised frame and under the container.

Use ladders and working platforms when required.

Do not utilise the hooklift components for climbing up the equipment.

If the work has to be done on top of the equipment, note and prevent the risk of falling.

All ladders, working platforms etc. must be kept clean from oil and grease.

Fasten and tighten all removed components and screw joints after the service.

Dispose of all extra material and oil in an appropriate manner, noting all environmental rules and regulations.

Before commencing any service or repair work, ensure that the vehicle is standing on an even surface with the hand brake engaged.

Remember to follow appropriate work safety and environmental instructions.

Record all service and repair work and any special matters which have appeared during the job.

Service table

Daily	
1.1	Check the safety functions
1.2	Check for possible damages and oil leaks
1.3	Check the control and warning lights
1.4	Check the function of the control unit
1.5	Check the load lockings

Weekly

2.1	Check the oil level
2.2	Check all valves, hoses and pipes
2.3	Check the clearance of the rear rollers and shafts
2.4	Check the clearances of other shafts
2.5	Check the central pressure lubrication system Check the amount of lubricant Check the function and connections of the central pressure lubrication system

Monthly

3.1	Wash the hooklift equipment carefully
3.2	Lubricate all the lubrication points
3.3	Check all the safety functions without a container
3.4	Check all frame constructions for possible damages and ensure their correct functioning
3.5	Check the tightness and condition of all fastening bolts
3.6	Check the gripping hook condition and wear
3.7	Check the whole hydraulic system for leaks and damages
3.8	Check the condition of all warning stickers

Once or twice a year

4.1	Change the hydraulic oil (annually or more often if it is dirty)
4.2	Change the return filter (twice a year or more often if it is blocked)
4.3	Check and clean/change ventilation plug (annually)

Hydraulics service



BE AWARE!

Servicing, repairs and installations of the hydraulic components may be done only by persons trained for the jobs.

Do not carry out any repair if you do not know the item to be repaired.

Never carry out any service or repair on system under pressure.

Stop the truck engine always before tightening or repairing hydraulic connections.

Do not try to locate a hydraulic hose leak with your hands. A leak from a pressurised system can penetrate the skin and cause serious injuries. A leak from a pressurised system can also cause a fire when hitting a hot object.

Avoid skin contact with oil. Protect also your eyes.

Do not carry out work on hydraulic components under a raised frame. Use always a mechanical support.

Do not remove any hydraulic components before supporting the frames and releasing hydraulic system pressure.

Pipe connections, hose lengths and materials must conform with the Multilift requirements. Use original Multilift spare parts or ensure otherwise that the components correspond with the highest working pressure used.

Ensure that the oil corresponds with the requirements and ensure its viscosity and cleanliness when adding oil into the system.

All changes to the recommendations concerning the oil and hydraulics must be verified in writing with Multilift.



BE CAREFUL!

Do not touch pressurised hydraulics. Do not remove any hydraulic components before the hooklift equipment has been supported mechanically.

General

- Keep the hydraulic system clean.
- Keep the oil in a clean, locked space. When adding oil, use a funnel which has a fine filter net.
- Keep funnels and containers free of dust.
- Always use clean towels or preferably high quality tissue.
- Before removing the hydraulic system components, clean the surrounding areas carefully with steam or fat removal agent.

Checking the oil level

When the middle frame and the hook arm are in operating position, the oil level should be in the middle of the sight glass.

Checking the return filter

Use a dirt indicator to check how dirty the return filter is. Replace the filter cartridge if the indicator is in the red zone when the pump works and the oil is at operational temperature.

Checking the air filter

Check the condition of the air filter. Clean and replace it as necessary.

Checking the condition of the oil

It is possible to examine ageing and deterioration of the quality of oil in the following way:

- dark colour is caused by overheating of oil
- milky and/or frothy oil contains water
- water can also be seen in separated oil
- air bubbles in oil are a sign of too little oil or of a leak in suction line
- solid particles indicate a component damage or old oil
- air is a sign of oil ageing as a result of overheating.

If you notice any of the above symptoms in oil, change it according to the following instructions.

Attention!

Hydraulic oils, especially mineral oils, are hazardous to environment. Therefore, follow all regulations pertaining to collecting and storing oil. Earth material polluted with oil must be processed according to relevant instructions.

If several successive containers switches are performed, the hydraulic oil may overheat (>60°C) making it necessary to install an oil cooler to the system.

Changing the hydraulic oil

1. Check that all piston rods of the cylinders are in retracted position.
2. Completely empty the oil tank via the drain plug.
3. Change the return filter.
4. Fill the tank with new oil via the return filter.
5. Check the air filter.



BE CAREFUL!

Hydraulic oils and mineral and more environment friendly oils can cause skin irritation and allergic symptoms. Hands and other exposed skin must be protected well. Wash your hands carefully after the oil change.

Hydraulic oil specifications

Quality classes: ISO 6743-4 type HV or
DIN 51524 part 3 type HVLP or
Swedish SMR standard for hydraulic oil (SHS).

Degree of cleanliness: 16/13 (ISO 4406).

Viscosity:

Ambient temperature °F (°C)					ISO-VG
-13	(-25)	...	50	(+10)	22
5	(-15)	...	68	(+20)	32
23	(-5)	...	86	(+30)	46
59	(+15)	...	122	(+50)	68

Oil qualities

Hydraulic system sets many requirements to the hydraulic oil characteristics. They contain amongst others:

- Lubrication requirements
- Oxidation prevention capability
- Corrosion protection
- Defoaming quality
- High viscosity index, in other words, low change of viscosity when the oil is heated.

In order to meet these requirements and qualities, additives are used in oils. Therefore it is important that the selected oil meets the characteristics for the operating environment in question. A lower ambient temperature is the same as the lowest starting temperature.

Note! Vegetable based bio oils are not allowed to be used. Only synthetic environment friendly oils that meet the above mentioned requirements are allowed.

Note! Do not mix different oil qualities. Mixing of different oils weakens generally their characteristics. If it is necessary to use an alternative oil, check with the supplier the characteristics and correspondence with the recommended oil.

Changing to biodegradable oil

To obtain the best results, the percentage of the mineral oil left in the system should not exceed 2%. The “Changing to biodegradable oil” –procedure might also apply to new systems because the hooklift is tested with mineral oil at the factory if otherwise noticed.

Safety

- Suitable eye and hand protection must be worn whilst carrying out this operation.
- Ensure suitable containers to hold the amount oil you will be draining are available before starting this operation.

Environment

- Ensure oil waste oil is disposed of safely and in accordance with any local environmental regulations.

Attention! Ask the oil supplier for instructions. If you do not receive any instructions, follow these recommendations:

Procedure

1. Completely empty the oil tank via the drain plug. Clean the oil tank carefully from oil and contamination. On older systems with heavy contamination, it may be necessary to remove the oil tank and flush out with a suitable flushing agent.
2. Completely empty the hydraulic cylinders, tubes, hoses and the suction hose to the pump.
3. Change the return filter.
4. Fill the tank with new oil via the return filter. Operate all cylinders carefully to ensure that they will be filled with oil. Ensure that the pump is filled all the time. Fill up the tank before it gets empty.
5. Drive for 2 or 3 days.
6. Check that all piston rods of the cylinders are in retracted position. Completely empty the oil tank via the drain plug and change the return filter. Fill up the oil tank with new oil and operate all cylinders carefully to ensure that they will be filled with oil. Ensure that the pump is filled all the time. Check that the oil level in tank remains in correct level.

Note! Synthetic esters can dissolve old contamination. If the performance of the hooklift appears to deteriorate before the oil filter change, inspect the filters and change if necessary.

Safety functions

Check the safety functions of all different movements; tipping, loading and unloading. Do the checks first without a container and thereafter with the container.

Safety functions

Check that:

- hydraulic body locks cannot be opened during tipping (tipping device approx. 0,5 m raised)
- moving of hook arm is not possible during tipping
- hook arm cannot be moved when the hydraulic body locks are closed
- body locks signal light is lit when the locks are not closed.

Check the functioning of the load holding valves with a loaded container:

- let the hooklift stay with the container raised for 5 minutes and check that the tipping device has not descended by itself (fig. **Tipping device** raised)
- let the hooklift stay in loading position for 5 minutes and check that the container has not descended down (fig. **Loading position**).

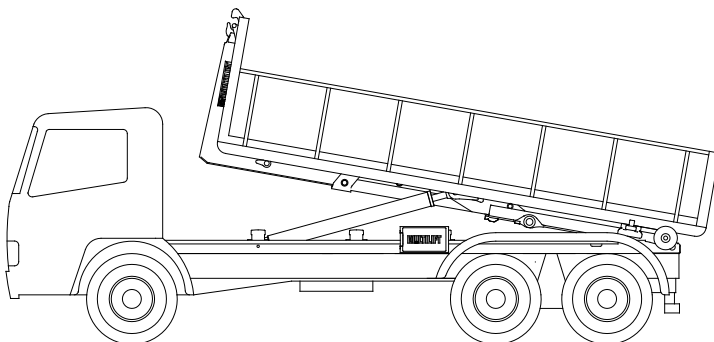

Tipping device raised

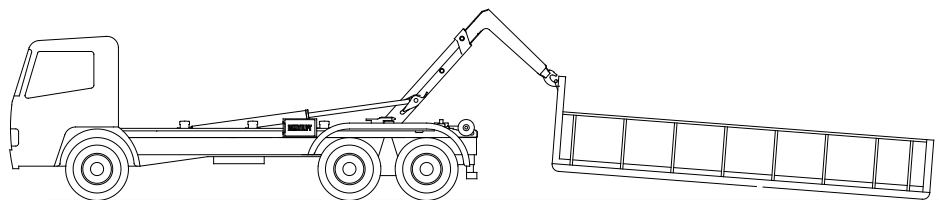

Loading position

General inspection

Check:

- steel construction for deformations and breakages
- hooklift fastening to the truck chassis, for breakages and loose bolts
- fastening of the rear rollers. Check the securings of all shafts.
- surfaces of piston rods. If the chromium surface of the rod is damaged, especially if the scratches are longitudinal, the rod or the whole cylinder must be changed.
- wear rate of the gripping hook. The original thickness of the hook must not be worn more than 10 %.
- wear rate of the slide pads. The maximum wear of the slide pads is 3 mm, but already a clearance of over 1 mm between the hook arm and the middle frame requires adding of space plates or replacement of slide pads.

See the picture on the following pages.

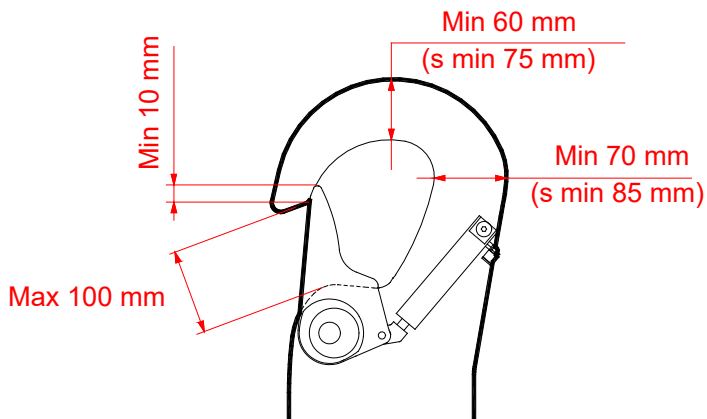

XR-S pneum.

Hook wear limits

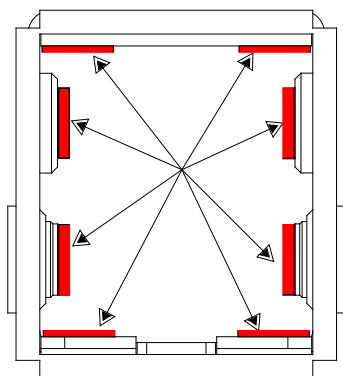

Slide pads in middle frame

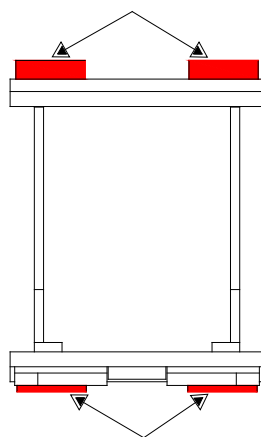

Slide pads in hook arm

Electric system

Maintenance and repair works in the electrical system may be carried out only by a trained electrician.

All the safety instructions and regulations related to electric work must be noted.

Use always only original electric components.

It is not allowed to make any additional connections to the electric system, wiring harnesses and valve coils.

Emergency operation

CAUTION!

Internal safety functions of the device do not work in manual control mode. Therefore, be especially careful when carrying out the movements.

If a failure happens in the electric system of the device, the device may be restored to its normal state, by operating the control valve manually:

1. Press down the button located at the end of valve for needed direction (101 or 114) and hold it down.
2. Press down the button located at the end of free circulation valve (108).
3. Release the buttons when you would like to stop the movement.

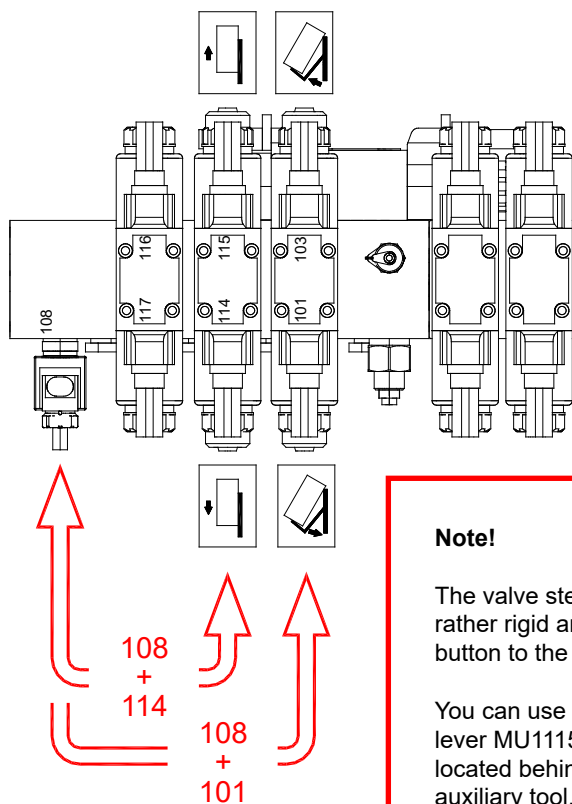

Note!

The valve stem return spring (101 or 114) is rather rigid and requires effort to push the button to the bottom.

You can use the emergency movement lever MU111568801 (additional equipment, located behind the valve stand) as an auxiliary tool.

How to change the backlight setting of the buttons

The illumination strength of the backlight is set in the cab controller software. The buttons to access the software and operations in the menu are as follows:

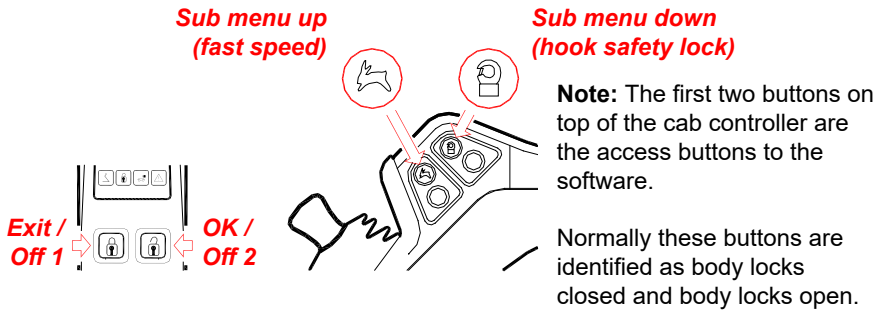

The procedure of setting the illumination strength of the backlight is the following:

<p>1.</p> <p>Press 10 s</p>	<p>Press the first row buttons simultaneously for 10 seconds.</p> <p>"C002" can be seen in the display while pressing the buttons.</p>
<p>2.</p>	<p>System will make 2 short beeps and all red LEDs will be shortly lit.</p> <p>A text "tESt" is shown in the display.</p>
<p>3.</p> <p>OK</p>	<p>Press the top button on right (locks open button).</p>

>>>

>>>
4.

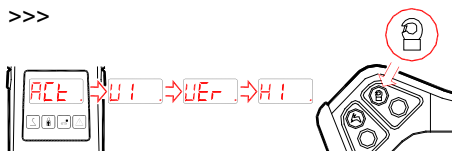

Text "**ACT**" will be shown in the display.

Press the **hook safety lock** button to scroll down the menu: **ACT** -> **UI** -> **UEr** -> **HI**.

5.

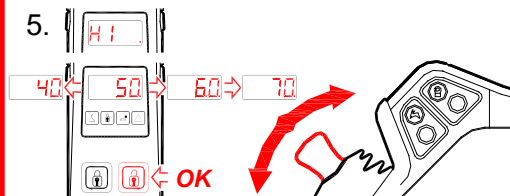

When text "**HI**" is shown wait until a value is shown.

Move the joystick forwards or backwards to adjust the active illumination strength between 0 - 100 %.

When you have the desired illumination level press the top right button (**locks open**) to save the value.

6.

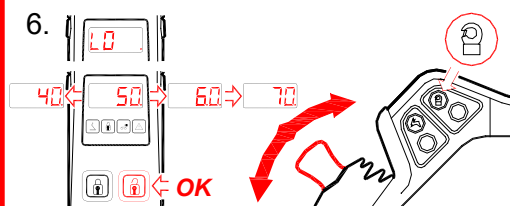

Press the **hook safety lock** button to show the "**LO**" in the display and wait until a value is shown.

Move the joystick forwards or backwards to adjust the inactive illumination strength between 0 - 100%.

When you have the desired illumination level press the top right button (**locks open**) to save the value.

>>>

>>>

7. Press the top left button (**locks closed**) to exit from the sub level menu.

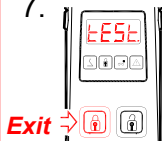

Text "**tES!**" will be shown.

8. Press both top buttons for 5 seconds to exit the software and return back to normal operation.

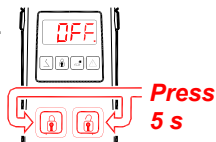

The text "**OFF**" will be shown for a couple of seconds in the display.

The backlight illumination will dim after 30 seconds of inactive period and light up when joystick is moved or any button pressed.

If both "**HI**" and "**LO**" are set to same value, there is no difference in the brightness.

FAULT FINDING

MULTILIFT PLC - Diagnostic Codes

The diagnostic codes of Multilift PLC can be seen on the display of control unit and on the service display.



Faults
F000 - F081



Conflicts
C000 - C020

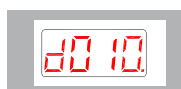

Diagnoses
d000 - d025



**Error codes
in the control unit**
01.01 -99.00

There are 4 types of codes:

- Faults F000 - F081 explaining any faults in electronic and electric system
- Conflicts C000 - C020 explaining any conflicts during use
- Diagnoses d000 - d025 explaining any illogical operation
- error codes 01.01 -99.00 in the control unit.













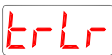

Faults are most critical errors and these usually need more thorough examination on the components or power feed. Usually there is a short circuit causing the error.

Conflicts can be less critical and usually there is a missing signal from a switch causing the error.

Diagnoses are usually caused by fault operation or missing signal from proximity switch.

If there are more than one error code in the system, the display in control unit is showing them in sequence and should be read all before any corrective action is started. The service display will show all errors in same screen.

The error codes will get off after fault is corrected / repaired. All error codes are recorded in a log file of the system memory and can be read afterwards with the service display.

DISPLAY MESSAGE	CAUSE
	DOT IS ON - CONTROL SYSTEM IS OK. THE DOT IS BLINKING DURING HOOKLIFT MOVEMENTS.
	HOUR COUNTER, 0001 OR HIGHER NUMBER APPEARING ABOUT 5 SEC DURING START UP.
	EXTERNAL CONTROLLER, 2GRC, 2GMR, TOP SEAT OR CRANE CONTROLLER IS ACTIVE.
	A STAY-ON HYDRAULICS IS ON. EMERGENCY OPERATION HYDRAULICS ON.
	A STAY-ON HYDRAULICS IS OFF. THE FUNCTION OF TRAILER TIPPING HYDRAULICS IS OFF. EMERGENCY OPERATION HYDRAULICS OFF.
	TRAILER TIPPING IS ON.
	EMERGENCY STOP IS ON.
	SERVICE TOOL ACTIONS ONGOING (SOFTWARE LOADING / DOWNLOADING, ETC.)
	CONFLICT CODE C001 - C020. SEE CODES ON FOLLOWING PAGES, IN THE CHAPTER "ERROR CODES, CONFLICTS".
	DIAGNOSTIC CODE D001 - D028. SEE CODES ON FOLLOWING PAGES, IN THE CHAPTER "ERROR CODES, DIAGNOSES".
	FAILURE CODE F001 - F081. SEE CODES ON FOLLOWING PAGES, IN THE CHAPTER "ERROR CODES, FAULTS".
	CONTROL UNIT ERROR CODE 01.01 - 99.00. SEE CODES ON FOLLOWING PAGES, IN THE CHAPTER "ERROR CODES, CONTROL UNIT".
	S = SHORT CIRCUIT, FOLLOWING WITH I/O MODULE PIN NUMBER, E.G. 123 = CONNECTOR XM1 PIN 23.
	N = NO VOLTAGE, FOLLOWING WITH I/O MODULE PIN NUMBER, E.G. 123 = CONNECTOR XM1 PIN 23.
	V = WRONG VOLTAGE, FOLLOWING WITH I/O MODULE PIN NUMBER, E.G. 123 = CONNECTOR XM1 PIN 23.

Diagnostic codes

ERROR CODE	COMMENTS / PROBLEM	LOCATION
PROGRAM DESCRIPTION	POSSIBLE ACTION	CONSEQUENCE
FAULTS		
-7F-	CAN BUS NOT ABLE TO COMMUNICATE WITH CONTROL BOX	CAN LINKING HARNESS
CAN BUS SIGNAL IS MISSING	CHECK YELLOW AND GREEN WIRE BETWEEN CONTROL UNIT AND 2024 MODULE	TOTAL STOP OF SYSTEM
F000	SUPPLY VOLTAGE IS BELOW 16 VOLTS	TRUCK
LOW POWER	CHARGE TRUCK BATTERY	TOTAL STOP OF SYSTEM
F001	INTERNAL ERROR ON 2024	2024
INTERNAL ERROR 1	REPLACE 2024 IF ERROR REPEATS	
F002	INTERNAL ERROR ON CONTROL BOX	CONTROL BOX
INTERNAL ERROR 2	REPLACE CONTROL BOX IF ERROR REPEATS	
F003	VALUES FROM PRESSURE SENSOR NOT LEGAL	2024
PRESSURE SENSOR	CHECK CONNECTION / REPLACE SENSOR	NO ACTION
F004	INTERNAL PARAMETER ERROR	2024
PARAMETER	CHECK PARAMETERS / REPLACE MAIN BOX	NO ACTION
F005	CAN BUS NOT ABLE TO COMMUNICATE WITH 2024	ANY POSITION
TIME OUT 1	CHECK BOX/CAN BUS WIRE & REPLACE IF NECESSARY	NO ACTION
F006	CAN BUS NOT ABLE TO COMMUNICATE WITH CONTROL BOX	ANY POSITION
TIME OUT 2	CHECK BOX/CAN BUS WIRE & REPLACE IF NECESSARY	NO ACTION
F007	PROGRAM HAS STOPPED RUNNING	2024
NOT RUNNING	POWER OFF/POWER ON TO RESET	NO ACTION
F008	CAN BUS NOT ABLE TO COMMUNICATE WITH ANY BOX	ANY POSITION
CAN BUFFER OVER RUN	CHECK CAN BUS WIRE & REPLACE IF NECESSARY	NO ACTION
F009	not used	

>>>

ERROR CODE	COMMENTS / PROBLEM	LOCATION
PROGRAM DESCRIPTION	POSSIBLE ACTION	CONSEQUENCE
F010	not used	
F011	(* Main cylinder floating short cut	2024
SHORT CIRCUIT	CHECK THE CABLES	
F012	(* Main cylinder floating voltage when not controlled	2024
Voltage when not controlled	CHECK THE CABLES	
F013	(* Main cylinder in 1 short cut	2024
SHORT CIRCUIT	CHECK THE CABLES	
F014	(* Main cylinder in 1 voltage when not controlled	2024
Voltage when not controlled	CHECK THE CABLES	
F015	(* Main cylinder in 2 short cut	2024
SHORT CIRCUIT	CHECK THE CABLES	
F016	(* Main cylinder in 2 voltage when not controlled	2024
Voltage when not controlled	CHECK THE CABLES	
F017	(* Main cylinder out 1 short cut	2024
SHORT CIRCUIT	CHECK THE CABLES	
F018	(* Main cylinder out 1 voltage when not controlled	2024
Voltage when not controlled	CHECK THE CABLES	
F019	(* Main cylinder out 2 short cut	2024
SHORT CIRCUIT	CHECK THE CABLES	
F020	(* Main cylinder out 2 voltage when not controlled	2024
Voltage when not controlled	CHECK THE CABLES	

>>>

ERROR CODE	COMMENTS / PROBLEM	LOCATION
PROGRAM DESCRIPTION	POSSIBLE ACTION	CONSEQUENCE
F021	(* Helping ram short cut	2024
SHORT CIRCUIT	CHECK THE CABLES	
F022	(* Helping ram voltage when not controlled	2024
Voltage when not controlled	CHECK THE CABLES	
F023	(* Sliding backwards short cut	2024
SHORT CIRCUIT	CHECK THE CABLES	
F024	(* Sliding backwards voltage when not controlled	2024
Voltage when not controlled	CHECK THE CABLES	
F025	(* Sliding forwards short cut	2024
SHORT CIRCUIT	CHECK THE CABLES	
F026	(* Sliding forwards voltage when not controlled	2024
Voltage when not controlled	CHECK THE CABLES	
F027	(* Fast speed short cut	2024
SHORT CIRCUIT	CHECK THE CABLES	
F028	(* Fast speed voltage when not controlled	2024
Voltage when not controlled	CHECK THE CABLES	
F029	(* Free flow short cut	2024
SHORT CIRCUIT	CHECK THE CABLES	
F030	(* Free flow voltage when not controlled	2024
Voltage when not controlled	CHECK THE CABLES	

ERROR CODE	COMMENTS / PROBLEM	LOCATION
PROGRAM DESCRIPTION	POSSIBLE ACTION	CONSEQUENCE
F031	(* Bodylocks In short cut	2024
SHORT CIRCUIT	CHECK THE CABLES	
F032	(* Bodylocks In voltage when not controlled	2024
Voltage when not controlled	CHECK THE CABLES	
F033	(* Bodylocks Out short cut	2024
SHORT CIRCUIT	CHECK THE CABLES	
F034	(* Bodylocks Out voltage when not controlled	2024
Voltage when not controlled	CHECK THE CABLES	
F035	(* Urb In short cut	2024
SHORT CIRCUIT	CHECK THE CABLES	
F036	(* Urb In voltage when not controlled	2024
Voltage when not controlled	CHECK THE CABLES	
F037	(* Urb Out short cut	2024
SHORT CIRCUIT	CHECK THE CABLES	
F038	(* Urb Out voltage when not controlled	2024
Voltage when not controlled	CHECK THE CABLES	
F039	(* Trailer tipping down short cut	2024
SHORT CIRCUIT	CHECK THE CABLES	
F040	(* Trailer tipping down voltage when not controlled	2024
Voltage when not controlled	CHECK THE CABLES	

>>>

ERROR CODE	COMMENTS / PROBLEM	LOCATION
PROGRAM DESCRIPTION	POSSIBLE ACTION	CONSEQUENCE
F041	(* Trailer tipping up short cut	2024
SHORT CIRCUIT	CHECK THE CABLES	
F042	(* Trailer tipping up voltage when not controlled	2024
Voltage when not controlled	CHECK THE CABLES	
F043	(* Tilting Forwards short cut	2024
SHORT CIRCUIT	CHECK THE CABLES	
F044	(* Tilting Forwards voltage when not controlled	2024
Voltage when not controlled	CHECK THE CABLES	
F045	(* Tilting Backwards short cut	2024
SHORT CIRCUIT	CHECK THE CABLES	
F046	(* Tilting Backwards voltage when not controlled	2024
Voltage when not controlled	CHECK THE CABLES	
F047	(* Bogie Blocking On short cut	2024
SHORT CIRCUIT	CHECK THE CABLES	
F048	(* Bogie Blocking On voltage when not controlled	2024
Voltage when not controlled	CHECK THE CABLES	
F049	(* Bogie Blocking Off short cut	2024
SHORT CIRCUIT	CHECK THE CABLES	
F050	(* Bogie Blocking Off voltage when not controlled	2024
Voltage when not controlled	CHECK THE CABLES	

ERROR CODE	COMMENTS / PROBLEM	LOCATION
PROGRAM DESCRIPTION	POSSIBLE ACTION	CONSEQUENCE
F051	(* Additional Hydraulics1 In short cut	2024
SHORT CIRCUIT	CHECK THE CABLES	
F052	(* Additional Hydraulics1 In voltage when not controlled	2024
Voltage when not controlled	CHECK THE CABLES	
F053	(* Additional Hydraulics1 Out short cut	2024
SHORT CIRCUIT	CHECK THE CABLES	
F054	(* Additional Hydraulics1 Out voltage when not controlled	2024
Voltage when not controlled	CHECK THE CABLES	
F055	(* Hook lock short cut	2024
SHORT CIRCUIT	CHECK THE CABLES	
F056	(* Hook lock supply voltage	2024
Voltage when not controlled	CHECK THE CABLES	
F057	(* Buzzer short cut	2024
SHORT CIRCUIT	CHECK THE CABLES	
F058	(* Buzzer supply voltage	2024
Voltage when not controlled	CHECK THE CABLES	
F059	(* PTO short cut	2024
SHORT CIRCUIT	CHECK THE CABLES	
F060	(* PTO voltage when not controlled	2024
Voltage when not controlled	CHECK THE CABLES	

>>>

ERROR CODE	COMMENTS / PROBLEM	LOCATION
PROGRAM DESCRIPTION	POSSIBLE ACTION	CONSEQUENCE
F061	(* TGO open short cut	2024
SHORT CIRCUIT	CHECK THE CABLES	
F062	(* TGO open voltage when not controlled	2024
Voltage when not controlled	CHECK THE CABLES	
F063	(* Quick Lowering On short cut	2024
SHORT CIRCUIT	CHECK THE CABLES	
F064	(* Quick Lowering On voltage when not controlled	2024
Voltage when not controlled	CHECK THE CABLES	
F065	(* Additional Hydraulics2 In short cut	2024
SHORT CIRCUIT	CHECK THE CABLES	
F066	(* Additional Hydraulics2 In voltage when not controlled	2024
Voltage when not controlled	CHECK THE CABLES	
F067	(* Additional Hydraulics2 Out short cut	2024
SHORT CIRCUIT	CHECK THE CABLES	
F068	(* Additional Hydraulics2 Out voltage when not controlled	2024
Voltage when not controlled	CHECK THE CABLES	
F069	(* Additional Hydraulics3 In short cut	2024
SHORT CIRCUIT	CHECK THE CABLES	
F070	(* Additional Hydraulics3 In voltage when not controlled	2024
Voltage when not controlled	CHECK THE CABLES	
F071	(* Add.Hydraulics3 Out short cut	2024
SHORT CIRCUIT	CHECK THE CABLES	

ERROR CODE	COMMENTS / PROBLEM	LOCATION
PROGRAM DESCRIPTION	POSSIBLE ACTION	CONSEQUENCE
F072	(* Add.Hydraulics3 Out voltage when not controlled	2024
Voltage when not controlled	CHECK THE CABLES	
F073	(* Add.Hydraulics4 In short cut	2024
SHORT CIRCUIT	CHECK THE CABLES	
F074	(* Add.Hydraulics4 In voltage when not controlled	2024
Voltage when not controlled	CHECK THE CABLES	
F075	(* Add.Hydraulics4 Out short cut	2024
SHORT CIRCUIT	CHECK THE CABLES	
F076	(* Add.Hydraulic4 Out voltage when not controlled	2024
Voltage when not controlled	CHECK THE CABLES	
F077	SUPPLY VOLTAGE FOR CONTROL UNIT SHORT CIRCUIT	2024 - CONTROL UNIT
SHORT CIRCUIT	CHECK POWER WIRES BETWEEN 2024 MODULE AND CONTROL UNIT	
F078	SUPPLY VOLTAGE FOR CONTROL BOX WHEN NOT CONTROLLED	2024
Voltage when not controlled	CHECK THE CABLES	
F079	TILT SENSOR VALUES NOT LEGAL OR NOT CONNECTED	2024
Tilt sensor middle frame out of range	CHECK CONNECTION / REPLACE SENSOR	FAST LOWERING DENIED
F080	TILT SENSOR VALUES NOT LEGAL OR NOT CONNECTED	2024
Tilt sensor subframe out of range	CHECK CONNECTION / REPLACE SENSOR	FAST LOWERING DENIED
F081	PRESSURE SENSOR VALUES NOT LEGAL OR NOT CONNECTED	2024
Pressure sensor main cylinder A out of range	CHECK CONNECTION / REPLACE SENSOR	FAST LOWERING DENIED

ERROR CODE	COMMENTS / PROBLEM	LOCATION
PROGRAM DESCRIPTION	POSSIBLE ACTION	CONSEQUENCE
CONFLICTS		
C000	NONE OR SEVERAL INPUTS PRESENT AT MODE SWITCH	CONTROL BOX
MODE SWITCH CONFLICT	REPLACE BOX	NO HOOKLIFT FUNCTION
C001	VALUES FROM JOYSTICK NOT LEGAL	CONTROL BOX
JOYSTICK CONFLICT	REPLACE JOYSTICK	NO HOOKLIFT FUNCTION
C002	BOTH INPUTS PRESENT AT CONTROL BOX	CONTROL BOX
ROCKER SWITCH CONFLICT 1	REPLACE ROCKER SWITCH 1	
C003	BOTH INPUTS PRESENT AT CONTROL BOX	CONTROL BOX
ROCKER SWITCH CONFLICT 2	REPLACE ROCKER SWITCH 2	
C004	BOTH INPUTS PRESENT AT CONTROL BOX	CONTROL BOX
ROCKER SWITCH CONFLICT 3	REPLACE ROCKER SWITCH 3	
C005	BOTH INPUTS PRESENT AT CONTROL BOX	CONTROL BOX
ROCKER SWITCH CONFLICT 4	REPLACE ROCKER SWITCH 4	
C006	BOTH INPUTS PRESENT AT CONTROL BOX	CONTROL BOX
ROCKER SWITCH CONFLICT 5	REPLACE ROCKER SWITCH 5	
C007	MIDDLE FRAME DOWN SENSOR IS 1 AND REAR FRAME IS 0	HOOKLIFT
INPUTS CONFLICT 1	CHECK MIDDLE FRAME DOWN & REAR FRAME DOWN SENSORS - REPLACE IF NECESSARY	
C008	MIDDLE FRAME DOWN SENSOR IS 1 AND MIDDLE FRAME NEARLY DOWN IS 0	HOOKLIFT
INPUTS CONFLICT 2	CHECK MIDDLE FRAME DOWN & MIDDLE FRAME NEARLY DOWN SENSORS - REPLACE IF NECESSARY	
C009	BODYLOCKS OPEN IS 1 AND BODYLOCKS CLOSED IS 1	HOOKLIFT
INPUTS CONFLICT 3	CHECK BODYLOCKS OPEN AND BODYLOCKS CLOSED SENSORS - REPLACE IF NECESSARY	

ERROR CODE	COMMENTS / PROBLEM	LOCATION
PROGRAM DESCRIPTION	POSSIBLE ACTION	CONSEQUENCE
C010	TIPPING LOCK OPEN IS 1 AND TIPPING LOCK CLOSED IS 1	HOOKLIFT
INPUTS CONFLICT 4	CHECK TIPPING LOCK OPEN AND TIPPING LOCK CLOSED SENSORS - REPLACE IF NECESSARY	
C011	JOYSTICK VALUE TOO SMALL	CONTROL BOX
JOYSTICK CONFLICT	CALIBRATE JOYSTICK - REPLACE IF NECESSARY	
C012	JOYSTICK VALUE TOO BIG	CONTROL BOX
JOYSTICK CONFLICT	CALIBRATE JOYSTICK - REPLACE IF NECESSARY	
C013	JOYSTICK HIGH VALUE WITHOUT DIRECTIONAL SWITCH, CENTER TAPP IN MIDDLE	CONTROL BOX
JOYSTICK CONFLICT	CALIBRATE JOYSTICK, CHECK WIRES - REPLACE IF NECESSARY	
C014	JOYSTICK LOW VALUE WITHOUT DIRECTIONAL SWITCH, CENTER TAPP IN MIDDLE	CONTROL BOX
JOYSTICK CONFLICT	CALIBRATE JOYSTICK, CHECK WIRES - REPLACE IF NECESSARY	
C015	JOYSTICK HIGH VALUE WITHOUT DIRECTIONAL SWITCH, CENTER TAPP NOT IN MIDDLE	CONTROL BOX
JOYSTICK CONFLICT	CALIBRATE JOYSTICK, CHECK WIRES - REPLACE IF NECESSARY	
C016	JOYSTICK LOW VALUE WITHOUT DIRECTIONAL SWITCH, CENTER TAPP NOT IN MIDDLE	CONTROL BOX
JOYSTICK CONFLICT	CALIBRATE JOYSTICK, CHECK WIRES - REPLACE IF NECESSARY	
C017	JOYSTICK VALUE 255	CONTROL BOX
JOYSTICK CONFLICT	CHECK JOYSTICK WIRES (GND) - REPLACE IF NECESSARY	
C018	JOYSTICK VALUE 0	CONTROL BOX
JOYSTICK CONFLICT	CHECK JOYSTICK WIRES (SUPPLY VOLTAGE / SIGNAL) - REPLACE IF NECESSARY	
C019	CENTER TAPP NOT IN MIDDLE	CONTROL BOX
JOYSTICK CONFLICT	CHECK JOYSTICK WIRES (CENTER TAPP) - REPLACE IF NECESSARY	
C020	INPUT PRESENT AT START UP	CONTROL BOX
SWITCH CONFLICT	DO NOT PRESS SWITCHES WHILE CONTROL BOX IS STARTING / CHECK AND REPLACE FAULTY SWITCHES	

ERROR CODE	COMMENTS / PROBLEM	LOCATION
PROGRAM DESCRIPTION	POSSIBLE ACTION	CONSEQUENCE
DIAGNOSES		
d000	BODYLOCKS ARE OPEN	
BODYLOCKS IN WRONG POSITION	CLOSE THE BODYLOCKS	NO HOOKLIFT FUNCTION
d001	BODYLOCKS ARE CLOSED	
BODYLOCKS IN WRONG POSITION	OPEN THE BODYLOCKS	NO HOOKLIFT FUNCTION
d002	BODYLOCKS ARE IN MIDDLE POSITION	
BODYLOCKS IN WRONG POSITION	OPEN/CLOSE THE BODYLOCKS OR CHECK SENSORS	
d003	TIPPING LOCK IS OPEN	
TIPPING LOCK IN WRONG POSITION	CHECK THE TIPPING LOCK CLOSED SENSOR / OPEN THE LOCKS / SLIDE FWD	NO HOOKLIFT FUNCTION
d004	TIPPING LOCK IS CLOSED	
TIPPING LOCK IN WRONG POSITION	CHECK THE TIPPING LOCK CLOSED SENSOR / CLOSE THE LOCKS / SLIDE BWD	NO HOOKLIFT FUNCTION
d005	TIPPING LOCK IS IN MIDDLE POSITION	
TIPPING LOCK IN WRONG POSITION	CHECK SENSORS	
d006	REAR FRAME IS UP (NOT DOWN)	
TIPPING LOCK IN WRONG POSITION		
d007	TIPPING LOCK IS CLOSED	
TIPPING LOCK IN WRONG POSITION		
d008	MIDDLE FRAME IS UP (NOT DOWN)	
MIDDLE FRAME IN WRONG POSITION		

ERROR CODE	COMMENTS / PROBLEM	LOCATION
PROGRAM DESCRIPTION	POSSIBLE ACTION	CONSEQUENCE
d009	MIDDLE FRAME IS UP (NOT NEARLY DOWN)	
MIDDLE FRAME IN WRONG POSITION		
d010	MIDDLE FRAME IS DOWN	
MIDDLE FRAME IN WRONG POSITION		
d011	MIDDLE FRAME IS NEARLY DOWN	
MIDDLE FRAME IN WRONG POSITION		
d012	REAR FRAME IS UP (NOT DOWN)	
REAR FRAME IN WRONG POSITION		
d013	REAR FRAME IS DOWN	
REAR FRAME IN WRONG POSITION		
d014	ARM IS NOT IN BACK POSITION	
TELESCOPIC / TILTING ARM IN WRONG POSITION	SLIDE / TILT BWD OR CHECK THE HORIZONTAL MOVEMENT BACK SENSOR	
d015	ARM IS IN BACK POSITION	
TELESCOPIC / TILTING ARM IN WRONG POSITION		
d016	PULL LIMITER IS ACTIVE	
PULL LIMITER IS ACTIVE	SLIDE / TILT BWD OR CHECK THE PULL LIMITER SENSOR	NO SLIDE FWD
d017	CRANE BODY IS ACTIVE	
CRANE BODY ON IS ACTIVE	SLIDE / TILT BWD OR CHECK THE CRANE BODY SENSOR	NO SLIDE FWD
d018	CATCH LOCKING RIGHT ARE ACTIVE	
CATCH LOCKING RIGHT ARE ACTIVE	OPEN THE RIGHT SIDE CATCH LOCKING / CHECK THE SENSOR	NO HOOKLIFT FUNCTION

>>>

ERROR CODE	COMMENTS / PROBLEM	LOCATION
PROGRAM DESCRIPTION	POSSIBLE ACTION	CONSEQUENCE
d019	CATCH LOCKING LEFT ARE ACTIVE	
CATCH LOCKING LEFT ARE ACTIVE	OPEN THE LEFT SIDE CATCH LOCKING / CHECK THE SENSOR	NO HOOKLIFT FUNCTION
d020	URB IS IN	
URB IN WRONG POSITION		
d021	URB IS OUT	
URB IN WRONG POSITION		
d022	URB IS IN MIDDLE POSITION	
URB IN WRONG POSITION		
d023	Not in use	
d024	Not in use	
d025		
LIFT FRAME NOT STOWED	LIFT FRAME STOWED SENSOR INACTIV	SLIDING BWD IS PREVENTED
d026		
STOWAGE IS NOT IN	OPERATE STOWAGE HOOKS IN	STOWAGE HOOKS ARE NOT IN
d027	HOOKLIFT IS DISABLED / ROAD MAT IS ON	
ROAD MAT FUNCTION IS ON	SWITCH THE ROAD MAT FUNCTION OFF	NO HOOKLIFT FUNCTION
d028	MIDDLE FRAME IS NOT MOVED TO REAR POSITION	
HOOK LOCK IS NOT ENABLED	MOVE MIDDLE FRAME TO REAR POSITION OR CHECK THE TILT INDICATOR	

>>>

ERROR CODE	COMMENTS / PROBLEM	LOCATION
PROGRAM DESCRIPTION	POSSIBLE ACTION	CONSEQUENCE
d040	MODES A1 AND A2 NOT ENGAGING	SLIDE FRAME
SLIDE IN CONTAINER AREA	MOVE SLIDE FRAME TO FLATRACK/BODY AREA	SLIDE FRAME TOO FAR FORWARD
d041		SLIDE FRAME
SLIDE IS NOT IN FRONT	OPERATE SLIDE FRAME TO FRONT	SLIDE FRAME TOO MUCH BACK
d042	TILTING ARM IS NOT MOVING IN A5 MODE WHEN MIDDLE FRAME IS DOWN OR AUTOMATIC MODES A1/A2 CANNOT BE ACTIVATED WHEN MIDDLE FRAME IS UP AND SLIDE ISN'T IN BACK POSITION	SLIDE FRAME
SLIDE NOT IN BACK POSITION	OPERATE SLIDE FRAME FULLY BACK	SLIDE FRAME IS NOT FULLY BACK OR THE SENSOR IS NOT ACTIVE
d044	SLIDE NOT FUNCTIONING	
SLIDING OUTOF RANGE	CHECK LINEAR SENSOR OF SLIDE FRAME AND CABLES	VALUES FROM LINEAR SENSOR OF SLIDE FRAME CYLINDER DIFFER FROM CALIBRATION

Error codes, control unit

POSSIBLE ERRORS INSIDE CONTROL UNIT

WHEN INTERNAL OR COMMUNICATION ERRORS OCCUR ON CONTROL UNIT FOLLOWING DIFFERENT ERROR CODES ARE DISPLAYED ON THE 7SEGMENT DISPLAYS. THEY ARE DISPLAYED ACCORDING TO THIS SCENARIO:
ERR 1ST -> ERR 2ND.

ERROR CATEGORIES

1.2	LOW	INFORMATION SHOWN ON DISPLAY AND CORRESPONDING FUNCTION STOPPED.
1.2	MEDIUM	INFORMATION SHOWN ON DISPLAY, AND THEN IS SYSTEM RE-STARTED AUTOMATICALLY TO REINITIATE SYSTEM CORRECTLY.
1.2	SEVERE	INFORMATION SHOWN ON DISPLAY, CAN-BUS DE-ACTIVATED AND SYSTEM LOCKED. NEEDS POWERCYCLE TO RESTART.

ERROR CODE		DESCRIPTION	CAUSE	ACTION
1.2	(CATEGORY)			
FAULTS				
01.01	MEDIUM	EEPROM FAILURE	ERROR DETECTED ON NON VOLATILE MEMORY	ERROR DISPLAYED ON DISPLAY, CAN MODULE SWITCHED TO PRE-OPERATIONAL STATE AND SYSTEM WILL SELF RESET AUTOMATICALLY. WAIT, UNTIL THE SYSTEM HAS STARTED.
01.02	SEVERE	FLASH MEMORY FAILURE	INCORRECT CHECKSUM ON FLASH MEMORY	ERROR DISPLAYED ON DISPLAY, SYSTEM SWITCHED TO ERROR STATE. SYSTEM MUST BE POWER CYCLED.
01.03	MEDIUM	STACK MEMORY FAILURE	INCORRECT SIZES IN CAN OPEN PROTOCOL, INCORRECT DATAFLOW, OR STACK OVERFLOW	ERROR DISPLAYED ON DISPLAY, CAN MODULE SWITCHED TO PRE-OPERATIONAL STATE AND SYSTEM WILL SELF RESET AUTOMATICALLY. WAIT, UNTIL THE SYSTEM HAS STARTED.
01.04	MEDIUM	RAM MEMORY FAILURE	INCORRECT RAM AND/OR HARDWARE IDENTIFICATION	ERROR DISPLAYED ON DISPLAY, CAN MODULE SWITCHED TO PRE-OPERATIONAL STATE AND SYSTEM WILL SELF RESET AUTOMATICALLY. WAIT, UNTIL THE SYSTEM HAS STARTED.

>>>

ERROR CODE 1.2 (CATEGORY)	DESCRIPTION	CAUSE	ACTION	
FAULTS				
03.00	LOW	ILLEGAL VOLTAGE DIGITAL OUTPUT (OUTPUT 1 - 4)	DIGITAL OUTPUT (1-4) HAVE ILLEGAL VOLTAGE, EXPECTED LOW DETECTED AS HIGH.	ERROR DISPLAYED ON DISPLAY.
04.00	LOW	SHORT CIRCUIT ON DIGITAL OUTPUT	DIGITAL OUTPUT (1 - 4) SHORT CIRCUITED OR OVERLOADED, CAN BE ANY OF THE 4 OUTPUTS.	ERROR DISPLAYED ON DISPLAY.
08.01	MEDIUM	CAN PASSIVE	CAN BUS IN PASSIVE MODE.	ERROR DISPLAYED ON DISPLAY, CAN MODULE SWITCHED TO PRE-OPERATIONAL STATE AND SYSTEM WILL SELF RESET AUTOMATICALLY. WAIT, UNTIL THE SYSTEM HAS STARTED.
08.02	MEDIUM	CAN I/O BUFFER OVERFLOW	CAN OVERRUN; EITHER THE CAN INPUT OR CAN OUTPUT BUFFER ARE FULL.	ERROR DISPLAYED ON DISPLAY, CAN MODULE SWITCHED TO PRE-OPERATIONAL STATE AND SYSTEM WILL SELF RESET AUTOMATICALLY. WAIT, UNTIL THE SYSTEM HAS STARTED.
08.03	MEDIUM	CAN PHYSICAL LAYER ERROR	BAD COMMUNICATION / TRANSMISSION.	ERROR DISPLAYED ON DISPLAY, CAN MODULE SWITCHED TO PRE-OPERATIONAL STATE AND SYSTEM WILL SELF RESET AUTOMATICALLY. WAIT, UNTIL THE SYSTEM HAS STARTED.
08.04	MEDIUM	CAN MESSAGE LENGTH ERROR	CAN MESSAGE LENGTH IS TOO LONG.	ERROR DISPLAYED ON DISPLAY, CAN MODULE SWITCHED TO PRE-OPERATIONAL STATE AND SYSTEM WILL SELF RESET AUTOMATICALLY. WAIT, UNTIL THE SYSTEM HAS STARTED.
08.05	MEDIUM	CAN MESSAGE LENGTH ERROR	CAN MESSAGE LENGTH IS TOO SHORT.	ERROR DISPLAYED ON DISPLAY, CAN MODULE SWITCHED TO PRE-OPERATIONAL STATE AND SYSTEM WILL SELF RESET AUTOMATICALLY. WAIT, UNTIL THE SYSTEM HAS STARTED.
08.06	MEDIUM	CAN TRANSMIT COLLISION	TO MANY COLLISIONS ON CAN-BUS.	ERROR DISPLAYED ON DISPLAY, CAN MODULE SWITCHED TO PRE-OPERATIONAL STATE AND SYSTEM WILL SELF RESET AUTOMATICALLY. WAIT, UNTIL THE SYSTEM HAS STARTED.

>>>

ERROR CODE		DESCRIPTION	CAUSE	ACTION
1.2	(CATEGORY)			
FAULTS				
11.00	LOW	ANALOG INPUT ERROR AT START-UP	JOYSTICK NOT IN NEUTRAL POSITION.	ERROR DISPLAYED ON DISPLAY. JOYSTICK FUNCTIONALITY WILL BE REMOVED UNTIL NEXT POWER CYCLE.
12.00	LOW	DIGITAL INPUT ERROR	ERROR DETECTED ON A SWITCH.	ERROR DISPLAYED ON DISPLAY. JOYSTICK FUNCTIONALITY WILL BE REMOVED UNTIL NEXT POWER CYCLE.
13.01	LOW	ANALOG INPUT ERROR, (JOYSTICK FRONT AND BACK MOVEMENT)	ERROR DETECTED ON JOYSTICK.	ERROR DISPLAYED ON DISPLAY. JOYSTICK FUNCTIONALITY WILL BE REMOVED UNTIL NEXT POWER CYCLE.
13.02	LOW	ANALOG INPUT ERROR. (JOYSTICK LEFT TO RIGHT MOVEMENT)	ERROR DETECTED ON JOYSTICK.	ERROR DISPLAYED ON DISPLAY. JOYSTICK FUNCTIONALITY WILL BE REMOVED UNTIL NEXT POWER CYCLE.
17.01	SEVERE	LOW POWER SUPPLY	LOW POWER SUPPLY (BELOW 8,5 VDC).	ERROR DISPLAYED ON DISPLAY, SYSTEM SWITCHED TO ERROR STATE. SYSTEM MUST BE POWER CYCLED.
17.02	SEVERE	HIGH POWER SUPPLY	HIGH POWER SUPPLY (ABOVE 36.0 VDC).	ERROR DISPLAYED ON DISPLAY, SYSTEM SWITCHED TO ERROR STATE. SYSTEM MUST BE POWER CYCLED.
18.01	SEVERE	SAFE STATE FAILURE	FAILED TO TAKE SYSTEM TO SAFESTATE.	ERROR DISPLAYED ON DISPLAY, SYSTEM SWITCHED TO ERROR STATE. SYSTEM MUST BE POWER CYCLED.
99.00	MEDIUM	UNDEFINED ERROR	UNDEFINED ERROR IN CONTROLLER. (SOFTWARE LOGIC IS INCORRECT)	ERROR DISPLAYED ON DISPLAY, CAN MODULE SWITCHED TO PRE-OPERATIONAL STATE AND SYSTEM WILL SELF RESET AUTOMATICALLY. WAIT, UNTIL THE SYSTEM HAS STARTED.

XR S SENSORS

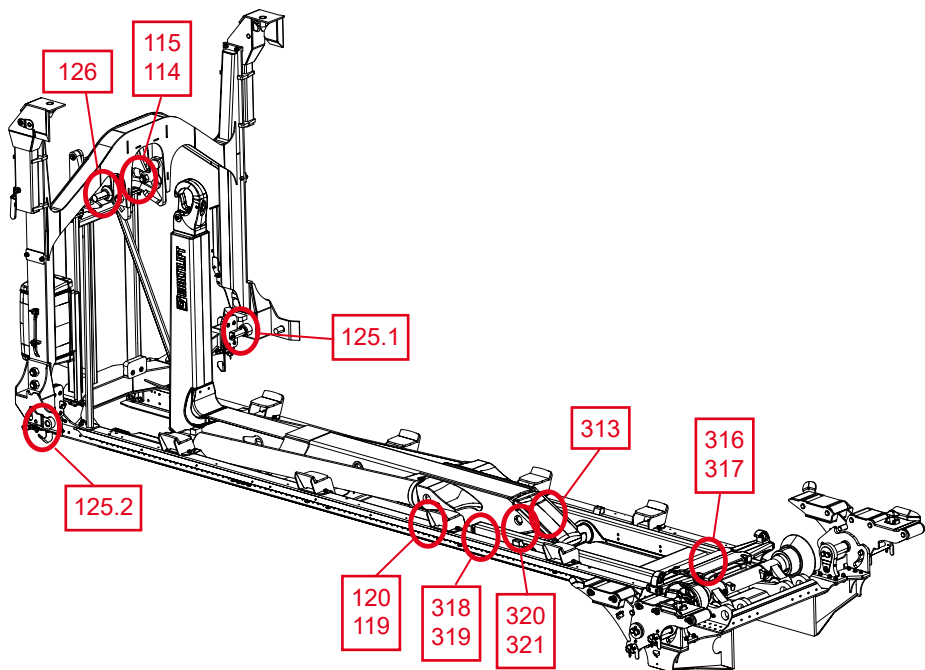

Sensors:

- 119 **Middle frame down**, Ø30 NO
- 120 **Middle frame nearly down**, Ø30 NO
- 313 **Main cylinder protection**, tilt indicator
- 316 **Body locks open**, Ø18 NO
- 317 **Body locks closed**, Ø18 NO
- 318 **Rear frame down**, Ø30 NO
- 319 **Tipping lock closed**, Ø30 NO
- 320 **Hook arm back**, Ø18 NO
- 321 **Pull limiter**, Ø18 NO
- 114 **Stowage in**, Ø18 NO
- 115 **Stowage out**, Ø18 NO
- 125.1 **Ratchet left**, Ø18 NO
- 125.2 **Ratchet right**, Ø18 NO
- 126 **Lifframe on the stowage**, Ø30 NO

LUBRICATION

Lubricate all the lubrication points at max 3 month intervals. A more recommended lubrication interval would be 1 month.

Note! The hooklift equipment contains plastic surface slide bearings. Use LITHIUM based general lubrication grease (EP2). Molybden based lubricant shortens the service life of the bearings.

If the hooklift is equipped with a central lubrication system, this will need to be checked according to the manufacturer's instructions.

Lubrication points >>>

XR21S

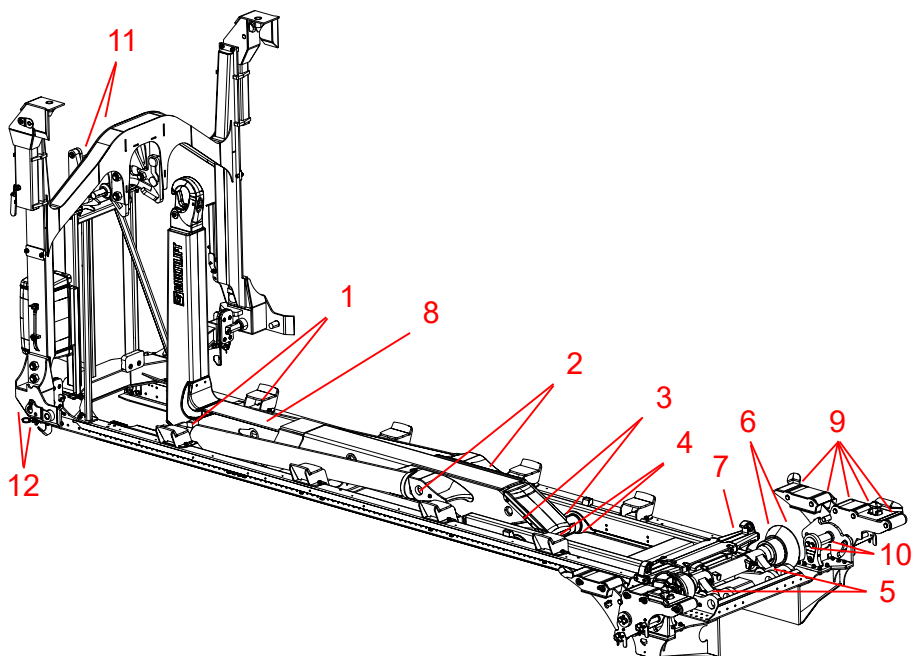

Lubrication points

XR21S

Point	Lubrication point	Number of nipples
1	Main cylinder lower fastening	1 + 1
2	Main cylinder upper fastening as well as discharge rollers (additional equipment)	1 + 1 1 + 1
3	Tipping device lock shafts	1 + 1
4	Middle frame bearing (under the rear frame)	1 + 1
5	Rear frame bearing	1 + 1
6	Rear rollers	2 + 2
7	Hooks of the hydraulic locks (if necessary)	spray (*)
8	Hook arm slide tube (if necessary)	spray (*)
9	ISO container support rollers, l & r	5 + 5
10	ISO container support roller shafts, l & r	1+2 + 1+2
11	Stowage hook shaft	1 + 1
12	Ends of lifftframe ratchets, l & r	1+1 + 1+1
Total number of nipples		36 (38)

*) It is recommended to use a drying material,
for example teflon or a silicon spray.

1 - 6, 9 - 12 Note! Use LITHIUM based general lubrication grease (EP2).
It is not allowed to use a graphite or molybdensulfide based lubricant.



EC declaration of conformity
of the machinery
(Directive 2006/42/EC, Annex II, part 1, sub A)

We Cargotec Finland Oy, Multilift
Nesteentie 36
FI-21200 Raisio
Finland

declare on our sole responsibility that the
Ground Level Demountable Equipment

Mark **Multilift**
Type **XR**
Serial number
Manufacturing year

- complies with the provisions of the machinery directive 2006/42/EC.
- also complies with the provisions of the directive on electromagnetic compatibility 2004/108/EC as amended.



DELIVERY CARD

Country	Country code
Distributor	

Multilift Demountables

<input checked="" type="checkbox"/>	Hooklift
<input type="checkbox"/>	Skiploader
<input type="checkbox"/>	Other

Customer:
Address:
Contact person:
Tel.:
E-mail:
Body builder / Dealer:

Model XR	Serial No.	Delivered
Pump model	Oil tank	
Truck model	Chassis No.	Registration No.

Accessories	Part No.	Serial No.

<p>The equipment described above has been received today, assembled and fully serviceable. The operator's manual and warranty conditions accompanying the equipment have been read through as witnessed below.</p> <p>Product operation instructions and safety instructions have been received.</p>	<p>Installation and delivery service carried out according to the manufacturer's instructions.</p>
<hr/> <p>Purchaser</p>	<hr/> <p>Seller / Body builder</p>
<p>To ensure that the warranty applies this delivery card should be received by the manufacturer no later than 30 days after commissioning.</p>	



*Cargotec improves the efficiency of cargo flows on land and at sea – wherever cargo is on the move. Cargotec's daughter brands, **Hiab, Kalmar** and **MacGregor** are recognised leaders in cargo and load handling solutions around the world. Cargotec's global network is positioned close to customers and offers extensive services that ensure the continuous, reliable and sustainable performance of equipment.*

© **Cargotec Finland Oy** reserves all rights for this user manual.



Cargotec Finland Oy
Multilift
P.O.Box 39
FIN-21201 Raisio, Finland
tel. +358 204 55 2399
fax +358 204 55 2231
www.cargotec.com