

YIELD STRENGTH
120,000 P.S.I. YIELD

CRANE MIN. SECTION
MODULUS REQUIRED
= 55.99 in.³

CRANE MIN. RBM/RAIL = 6,718,820 IN-LBS

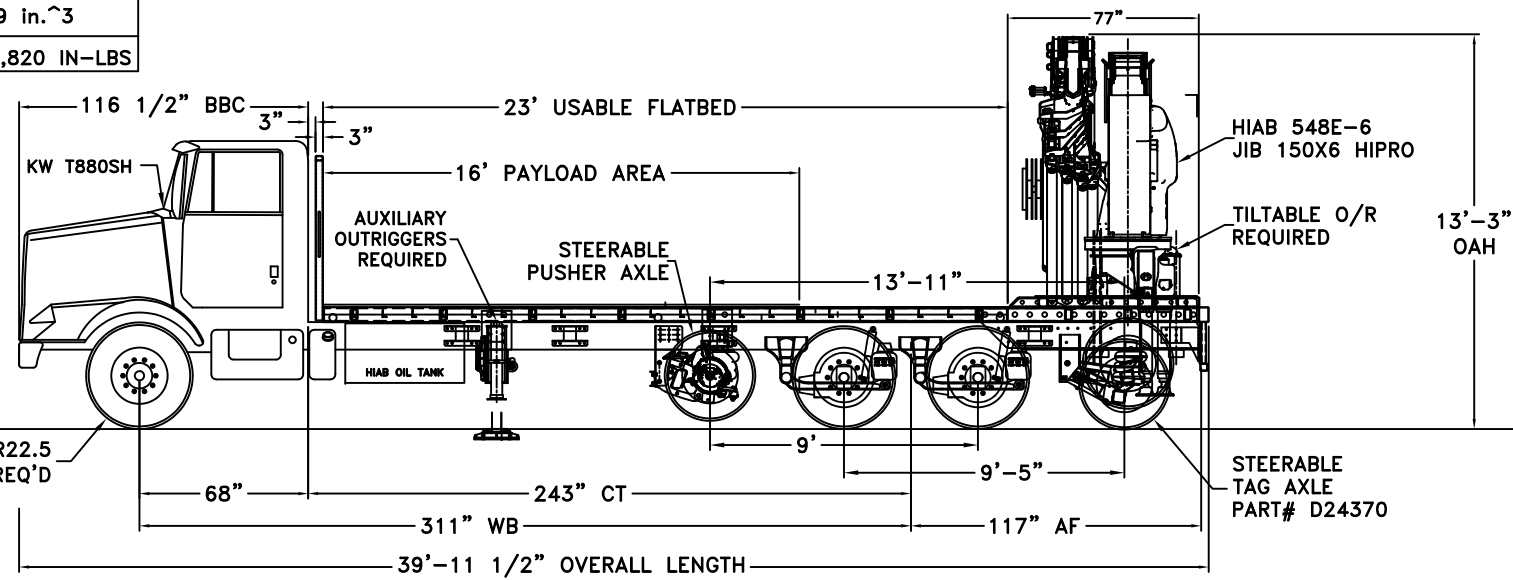

CRANE MAY BE DERATED
IN FRONT QUADRANTS AS
MUCH AS 25%. ACTUAL
DERATING SHALL BE BASED
ON PHYSICAL TESTING.

TRUCK, HIAB CRANE & ACCESSORIES WEIGHT DISTRIBUTION, NO PAYLOAD, LIFT AXLES DOWN.	
TOTAL WEIGHT ON FRONT AXLE	= 11,840 LBS.
TOTAL WEIGHT ON PUSHER AXLE	= 6,000 LBS.
TOTAL WEIGHT ON TANDEM AXLE	= 22,940 LBS.
TOTAL WEIGHT ON TAG AXLE	= 11,000 LBS.
FRONT AXLE WT. PERCENTAGE	= 23 %
PUSHER AXLE WT. PERCENTAGE	= 12 %
TANDEM AXLE WT. PERCENTAGE	= 44 %
TAG AXLE WT. PERCENTAGE	= 21 %
GROSS VEHICLE WEIGHT	= 51,780 LBS.

TRUCK, HIAB CRANE & ACCESSORIES WEIGHT DISTRIBUTION, WITH PAYLOAD, LIFT AXLES DOWN.	
TOTAL WEIGHT ON FRONT AXLE	= 16,860 LBS.
TOTAL WEIGHT ON PUSHER AXLE	= 13,000 LBS.
TOTAL WEIGHT ON TANDEM AXLE	= 26,000 LBS.
TOTAL WEIGHT ON TAG AXLE	= 11,000 LBS.
FRONT AXLE WT. PERCENTAGE	= 25 %
PUSHER AXLE WT. PERCENTAGE	= 20 %
TANDEM AXLE WT. PERCENTAGE	= 39 %
TAG AXLE WT. PERCENTAGE	= 16 %
GROSS VEHICLE WEIGHT	= 66,860 LBS.
PAYLOAD AS SHOWN (16' AREA)	= 15,080 LBS.

*WATER LEVEL PAYLOAD = 12,090 LBS.

TRUCK SPECIFICATIONS	
TRUCK MODEL	= KENWORTH T880 SH
WHEELBASE	= 311"
CAB TO TANDEM	= 243"
AXLE-TO-FRAME	= 117"
FRONT CURB WEIGHT	= 11,200 LBS.
TANDEM CURB WEIGHT	= 9,200 LBS.
FRONT G.A.W.R.	= 20,000 LBS.
TANDEM G.A.W.R.	= 46,000 LBS.
YIELD STRENGTH OF EACH FRAME RAIL	MINIMUM SECTION MODULUS REQUIRED
120,000 P.S.I. YIELD	= 38.00 in. ³
MINIMUM RBM/RAIL OF 4,560,000 IN-LBS	

NOTES:
 DOUBLE FRAME CHASSIS REQUIRED.
 FRAME RAIL MINIMUM OF 38.0 SECTION MODULUS REQUIRED.
 FULL LENGTH SUB-FRAME REQUIRED:
 6"x4"x1/2" RECT. TUBING (ON TOP OF FRAME RAIL)
 5"x3"x1/2" RECT. TUBING (CROSSMEMBERS EVERY 3 FT.)
 1/2" TOP AND 3/8" BOTTOM PLATES REQUIRED.
 TAG AXLE MUST BE DOWN IN ALL FORWARD GEARS.
 CURB WEIGHTS ARE ESTIMATED.
 FLATBED & LIFT AXLE WEIGHTS ARE ESTIMATED.
 HANDLING & MANEUVERABILITY IS POOR WITH LONG WHEELBASE.

TRUCK RUNS IN MICHIGAN.
 18,000 LBS. ALLOWED ON FRONT AXLE.
 13,000 LBS. ALLOWED ON PUSHER AXLE.
 26,000 LBS. ALLOWED ON TANDEM AXLE.
 11,000 LBS. ALLOWED ON TAG AXLE.
 68,000 LBS. ALLOWED FOR GROSS WEIGHT.
 ALLOWABLE LEGAL OVERALL LENGTH IS 40'.

NOTICE:
 THE DRAWING PURPOSE IS TO INTRODUCE
 A GENERAL CONCEPT OF A PROPOSED IDEA.

NOTICE:
 THIS WEIGHT DISTRIBUTION IS BASED ON ESTIMATED
 WEIGHTS AND IS ONLY AS ACCURATE AS THOSE
 ESTIMATES. ACTUAL WEIGHTS MAY CHANGE
 THE RESULTS OF THIS WEIGHT DISTRIBUTION.

Hiab, Inc.
 Hiab, Inc.
 12233 Williams Road
 Perrysburg, Ohio 43551
 Tel (419) 482-6000
 Fax (419) 482-6001

Tolerances - unless otherwise noted.
 Tolerances are in inches

2-PLACE ± 0.00..... .03
 3-PLACE ± 0.00..... .015
 ANGULAR ± 1'
 FRACTIONAL ± 1/16"
 Break all sharp corners
 unless otherwise specified.

THIS PROPERTY AND ALL INFORMATION THEREIN IS THE PROPERTY OF Hiab, Inc., 12233 WILLIAMS RD, PERRYSBURG, OHIO 43551 AND IS CONFIDENTIAL. IT MUST NOT BE MADE PUBLIC OR COPIED. THIS DRAWING IS LOANED TO RETURN UPON DEMAND AND SHALL NOT BE USED DIRECTLY OR INDIRECTLY IN ANY WAY DETRIMENTAL TO OUR INTERESTS. OUR PRIOR SPECIFIC APPROVAL IS REQUIRED FOR EXPOSURE OF THIS DRAWING TO OTHERS FOR ANY PURPOSE.

Next Assy.
 Dwg/Cad file no.
 548 / SALES

Drawing Title: HIAB 548E-6 JIB 150X6 HIPRO CRANE		Project Name: SALES LAYOUT	
Drawn by: Date: CSV 4-6-18	Size: C	Part No.	
Approval: Date Approved:	Scale: N/A	unit wt.	Eng. Job no.: