

MULTILIFT



MULTILIFT AT WORK
WASTE & RECYCLING

MULTILIFT HOOKLIFTS QUICK CHANGE ARTIST



MULTILIFT Hooklifts are the pound-for-pound payload champ in the waste and recycling industry. We've driven weight out of the system at every turn, without sacrificing integrity. The result is maximum legal payload with every trip. When looking at ROI, MULTILIFT pays for itself in months, not years. Couple this with our best-in-class operating speed, system efficiencies, industry leading warranty, proven reliability and unmatched safety focus. MULTILIFT will get you in and out of job sites fast, without compromising the operator's safety. And for good measure, throw in environmentally safe features, including noise reduction technology, bio-oil ready, etc., MULTILIFT can be trusted to keep you moving, day-in and day-out.

MULTILIFT ADDRESSES YOUR INDUSTRY PAIN POINTS

Diversify the scope of your business and get more out of your operations for an improved bottom line. MULTILIFT hooklifts and ISO container carriers tackle all your on- and off-loading needs or double as a true dump truck. Covering Class 5 through Class 8 chassis, capacities of 12,000 lb. to 72,000 lb. and body/container lengths of 10' to 24', MULTILIFT has you covered.

SAFETY - MULTILIFT hooklifts are the safest in the industry. At the bare minimum, all systems include: in cab operation, body up warning system, hook safety latch, maintenance support and mechanical body locks. Operate with peace-of-mind.

EFFICIENCY - The right equipment can change the course of your business. With a MULTILIFT on the back, you'll instantly increase daily productivity. Incorporating the best safety features, smooth and fast operation built on a solid core, a MULTILIFT will help you start and finish each job efficiently and on time. Loading and unloading capabilities are maximized for a truck's available payload as well as the working environment.

DOWNTIME - MULTILIFT's renowned reliability combines with unequalled product support. Every MULTILIFT hooklift is backed by a nationwide dealer and service network to ensure your equipment stays dialed in and operational.

TRAINING - Training and educating operators takes time, but the MULTILIFT's leading-edge technology allows customers to manage their resources in the best way, whether the operator is highly experienced or a new employee without losing too much time.

RELIABILITY - MULTILIFT is the industry leader in reliability and backed by the industry's only 2-year all parts warranty. Superior engineering and cutting-edge technology ensure optimum longevity and service life of your equipment.

REVENUE - Designed using a high-strength light-weight steel (up to 40% lighter), MULTILIFT maximizes your legal payload and profits with every trip. Add operating speeds up to 60% faster than competitive brands, MULTILIFT gets you in and out of job sites in record time. More trips per day equal more coin in your pocket.



Hiab HiConnect™ is a web-based dashboard that displays insights on equipment usage, location, time in operation, idle time, and productivity level. By enabling new insights, it helps you to further increase efficiency, productivity, and safety. HiConnect is the latest technology in terms of connectivity capabilities. Being able to remotely access data is key to maximizing your business with facts instead of assumptions. HiConnect maintains constant contact with all units, giving fleet managers the ability to stop unsafe behavior and usage before an incident happens. With the ability to view service history and plan upcoming services, your fleet has minimum downtime and increases daily efficiencies.



MULTILIFT



FEATURES THAT BRING SOLUTIONS

STANDARD PRODUCT FEATURES	XR SERIES	OPT SERIES	ULT SERIES
Electric Cab Control	X	X	X
High Tensile Steel Construction	X	X	X
Dual Pivot Design (<i>true dumping</i>)	X	X	X
Hook Safety Latch	X	X	X
Body Up Warning Light	X	X	X
Sensors / Wiring - IP67	X	X	X
Zinc Primer / Top-Coat Black	X	X	X
2-Speed / PLC Controller (<i>smart system</i>)			X
Soft Lowering (<i>dump cycle</i>)		X	X
Friction Relief (<i>loading / unloading</i>)			X
Float Function (<i>rough road assist</i>)		X	X
Pull Limiter (<i>manage short bodies</i>)		X	X
Solid Cast Inserts (<i>critical stress points</i>)		X	X
Product Warranty (<i>all parts / structural</i>)	2-yr / 3-yr	2-yr / 3-yr	2-yr / 5-yr



Hiab's nDurance™ paint is an anti-corrosion paint system using nano technology for the ultimate anti-corrosion coating, maintaining a rust-free **reliable** crane.



Hiab ProCare™ is a proactive preventative maintenance service contract, designed to **maximize uptime** of all Hiab equipment by maintaining proper service intervals.

We have invested heavily in our **Nationwide Service and Support** team as part of our commitment to our customers. With 28 branch locations and over 200 factory-trained mobile service technicians, your Hiab loader crane is protected with an unrivaled coast-to-coast service network, greatly reducing the **downtime** of your equipment, thus **reducing overhead costs**.

MULTILIFT XR10S / ULTIMA 21S Technical Specifications



MULTILIFT XR10S

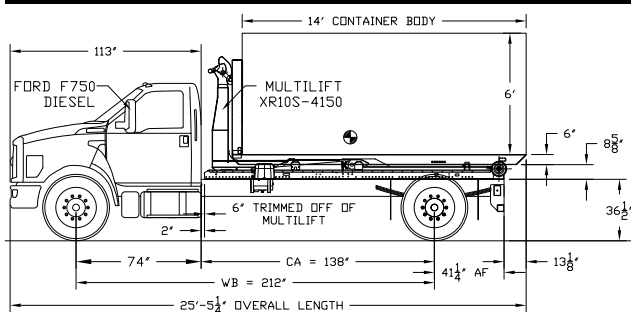

MULTILIFT ULTIMA 21S

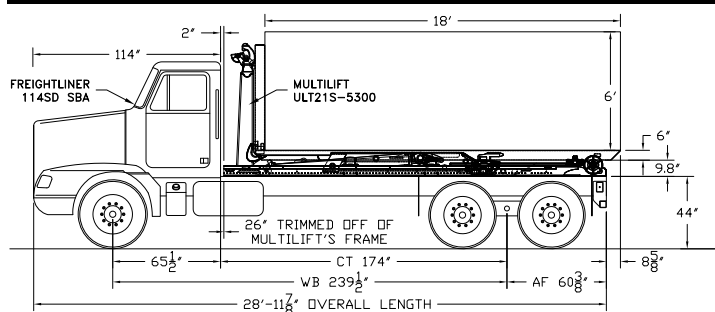

Our extensive stock of parts at our **Regional Distribution Center** ensures next-day delivery on almost all items, reducing **downtime** and **saving you money**. The same team you trust to deliver high-quality, premium products to your exact requirements can also be trusted to keep you moving.



Hiab's **Leading Warranty** exceeds the industry's standard terms because our products are designed to last longer and provide many years of **reliable** service.



MULTILIFT's innovative design elements have the working environment in mind. All MULTILIFT Hooklifts models have Low System Weight and Optimized Cylinder Sizes, which reduce fuel consumption and costs, while lowering CO2 emissions. The ULTIMA and OPTIMA models have an optional Performance Package, which provides additional eco-friendly features, including Automatic Sequence Control, Fast Lowering, Fast Tipping, Friction Relief, all of which provide less noise pollution, reduced CO2 emissions, and allow the machine to maintain an increased speed without burning more fuel.

HIAB SERVICE CENTERS

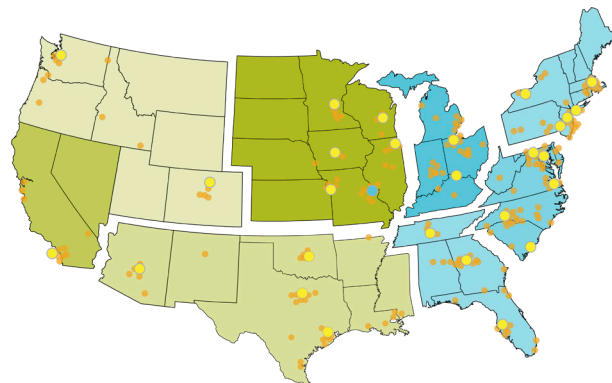

Our commitment to you

Hiab is the world's leading provider of on-road load handling equipment, intelligent services, smart and connected solutions. Hiab's class-leading load handling equipment includes HIAB, EFFER and ARGOS loader cranes, LOGLIFT and JONSERED forestry and recycling cranes, MOFFETT and PRINCETON truck mounted forklifts, MULTILIFT skiploaders and hooklifts, and tail lifts under the ZEPRO, DEL, and WALTCO brands. As the industry pioneer and with a proud 75 year history, Hiab is committed to be the preferred partner and solution provider to its customers and shape the future of intelligent load handling. www.hiab.com Hiab is part of Cargotec Corporation. www.cargotec.com

For all your sales and service needs, call our nationwide hotline at 419.482.6000 to find your nearest Hiab USA branch.



HIAB



Hiab USA Inc
12233 Williams Road
Perrysburg, OH 43551 USA
tel. +419 482 6000
www.hiab.us.com

