



## HIAB MEDIUM RANGE CRANES READY TO DELIVER ALL-AROUND PERFORMANCE

The HIAB medium range cranes provide optimal performance. The HiDuo control system is the best price-performance remote controlled system you can choose, assuring high levels of safety matched to many functions that make any job easy. Take

advantage of the many options and functions that support and protect your everyday work and business. Ideal for a wide range of lifting purposes and for many applications. The special nDurance paint protection finish further contributes to making the crane look and last longer.

### HIAB ADDRESSES YOUR INDUSTRY PAIN POINTS

Hiab loader cranes are stronger, tougher, and smarter, easily adapting to the ever changing needs of the roofing industry. With reliable support, intelligent services, and a growing number of connected solutions, Hiab loader cranes will maximize performance by offering the right solution for loading, unloading, or moving materials. Like no other truck mounted equipment provider, Hiab understands the specific requirements and realities of any industry and will help secure a safer, more efficient operation with reduced downtime while maximizing revenue.

**SAFETY** - Hiab's industry leading technology provides world class, industry leading safety features that keep operators safe and in control, minimizing risk to individuals or the environment. With the smart technology solutions of Hiab's loader cranes, human driven errors and unsafe operations are reduced.

**EFFICIENCY** - Hiab's advanced technology drives the performance of the equipment resulting in superior operation efficiencies. Hiab's class-leading products can not only be used by operators of different skill levels, but are also helpful with everchanging resources, supporting business efficiency and increasing productivity.

**DOWNTIME** - Hiab's renowned reliability combined with industry leading safety features and control systems is proven to reduce downtime, while our nationwide service network ensures that equipment is maintained with minimal oversight.

**TRAINING** - Training and educating operators takes time, but Hiab's advanced control systems and technology allows customers to manage their resources in the best way, whether the operator is highly experienced or a new employee without losing too much time.

**RELIABILITY** - Hiab loader cranes are the industry leaders in the area of reliability. Our premium engineering and cutting edge operation management features ensure optimum longevity and service life of your equipment. All backed up with the most comprehensive warranty in the market.

**REVENUE** - Hiab loader cranes provide many cost benefits that are ideal for businesses with repetitive, efficient operations. With a reliable design, quality materials, game changing smart technology, and industry specific innovation, investing in Hiab equipment provides a total package for any industry.

### FEATURES THAT OPTIMIZE OPERATIONS



The **HiDuo** control system with XSDrive remote control brings an unprecedented level of **safety** to operations without reducing performance. This highly flexible system will make your business safer and more profitable with all electronic functions, managed by our SPACE system, which includes Overload Protection (OLP) and Automatic Duty Control (ADC). When approaching an overload condition, the crane gives an audible and visual signal at 90% capacity and will stop all radius increasing functions once full capacity has been reached.

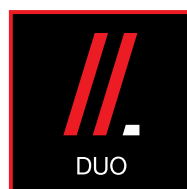

A **Duo** crane is manually operated and easy to use, but it automatically adds a higher level of safety. The crane's SPACE system provides automatic assistance, making it easier to operate the crane safely without special training. Plus it tracks the crane's usage, providing valuable statistics and indicating when service and repairs are needed.



The **HIAB XSDrive** remote control increases **efficiency** by giving the operator freedom of movement to use the best possible position to view the load. It features two-way communication with the crane, proportionally controlling movements. The **HIAB XSDrive** remote control is **reliable** and worry-free industrial component designed to last the life of the crane.



Hiab's **nDurance™** paint is an anti-corrosion paint system using nano technology for the ultimate anti-corrosion coating, maintaining a rust-free **reliable** crane.



Hiab **ProCare™** is a proactive preventative maintenance service contract, designed to **maximize uptime** of all Hiab equipment by maintaining proper service intervals.

Our extensive stock of parts at our **Regional Distribution Center** ensures next-day delivery on almost all items, reducing **downtime** and **saving you money**. The same team you trust to deliver high-quality, premium products to your exact requirements can also be trusted to keep you moving.



Hiab's **Leading Warranty** exceeds the industry's standard terms because our products are designed to last longer and provide many years of **reliable** service.



Hiab's innovative design elements have the working **environment** in mind. HIAB cranes have a high performing control system, which saves on fuel consumption. Our

Valve 200, when combined with a variable displacement piston pump, provides the highest level of speed, precision, and efficiency available. On average, a HIAB crane with the V200 and variable pump will consume 325 gallons less diesel fuel per year compared to other models using fixed displacement pumps.

### HIAB USA LOCATIONS

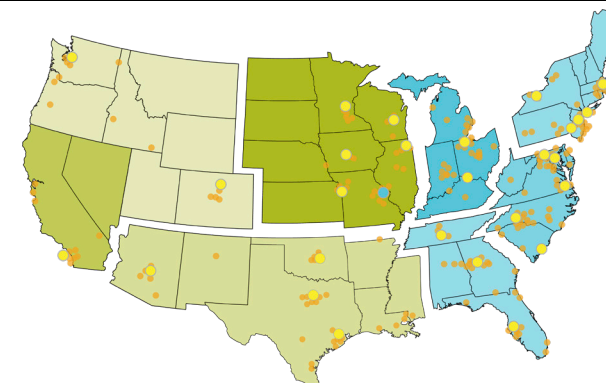

#### Our commitment to you

Hiab is the world's leading provider of on-road load handling equipment, intelligent services, smart and connected solutions. Hiab's class-leading load handling equipment includes HIAB, EFFER and ARGOS loader cranes, LOGLIFT and JONSERED forestry and recycling cranes, MOFFETT and PRINCETON truck mounted forklifts, MULTILIFT skiploaders and hooklifts, and tail lifts under the ZEPRO, DEL, and WALTCO brands. As the industry pioneer and with a proud 75 year history, Hiab is committed to be the preferred partner and solution provider to its customers and shape the future of intelligent load handling. www.hiab.com Hiab is part of Cargotec Corporation. www.cargotec.com

For all your sales and service needs, call our nationwide hotline at 419.482.6000 to find your nearest Hiab USA branch.



Hiab USA Inc  
12233 Williams Road  
Perrysburg, OH 43051 USA  
tel. +419 482 6000  
www.hiab.us.com

V2022.03.15

**HiCONNECT™** Hiab HiConnect™ is a web-based dashboard that displays insights on equipment usage, location, time in operation, idle time, and productivity level. By enabling new insights, it helps you to further increase efficiency, productivity, and safety. HiConnect is the latest technology in terms of connectivity capabilities. Being able to remotely access data is key to maximizing your business with facts instead of assumptions. HiConnect maintains constant contact with all units, giving fleet managers the ability to stop unsafe behavior and usage before an incident happens. With the ability to view service history and plan upcoming services, your fleet has minimum downtime and increases daily efficiencies.

# PRODUCT RANGE HIAB MEDIUM RANGE CRANES



# X-HIDUO 138

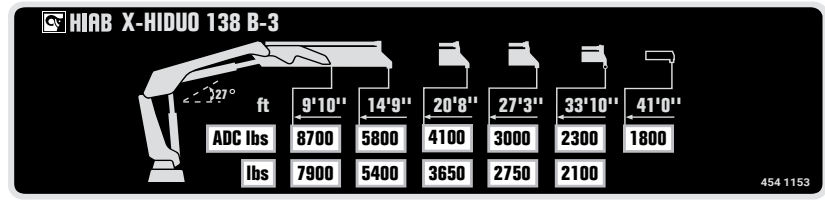
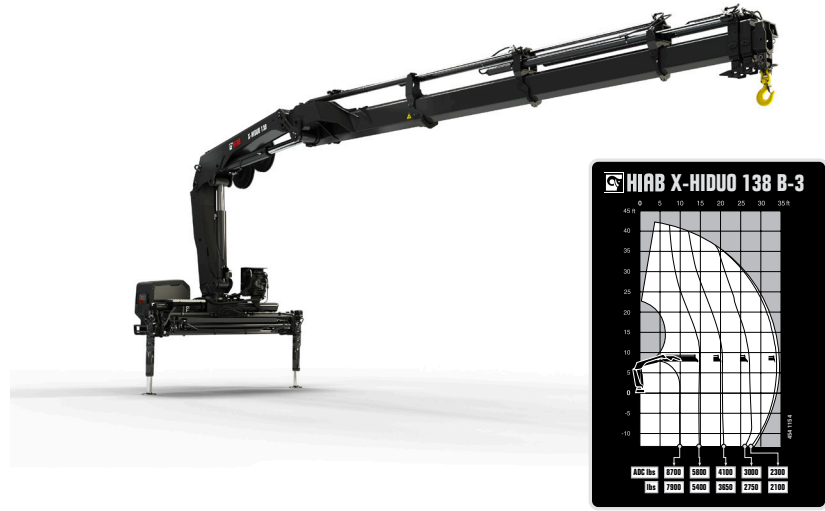

# X-HIPRO 162

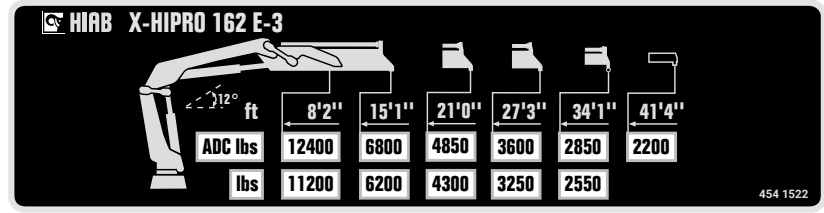
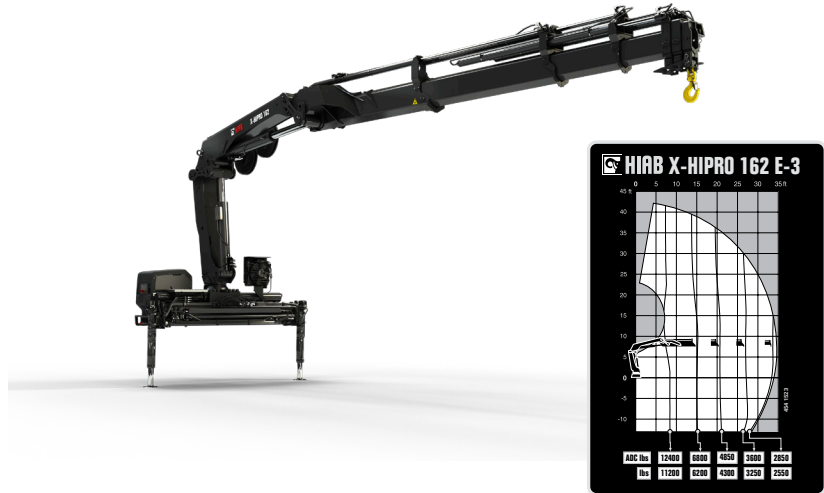

# X-HIDUO 228

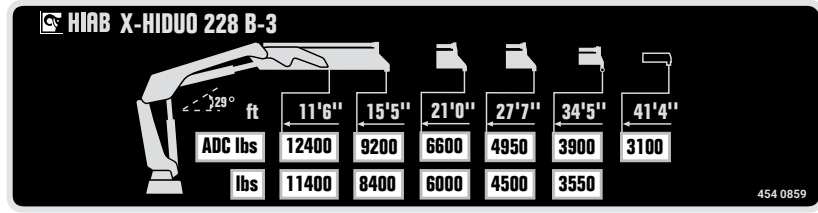

# X-HIDUO 258

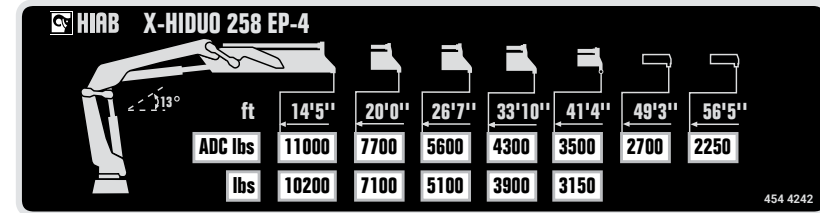
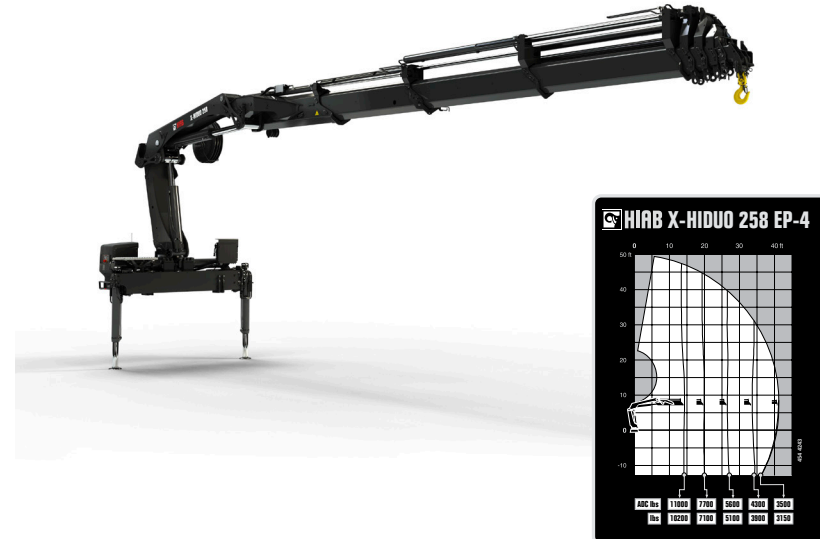

# X-HIPRO 302

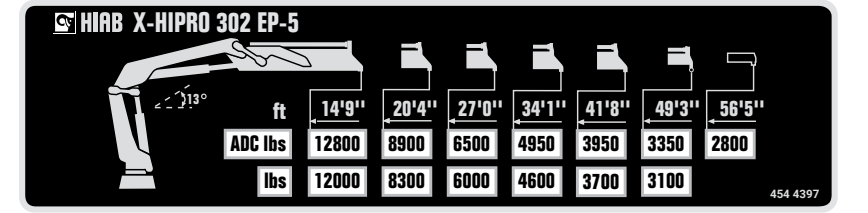
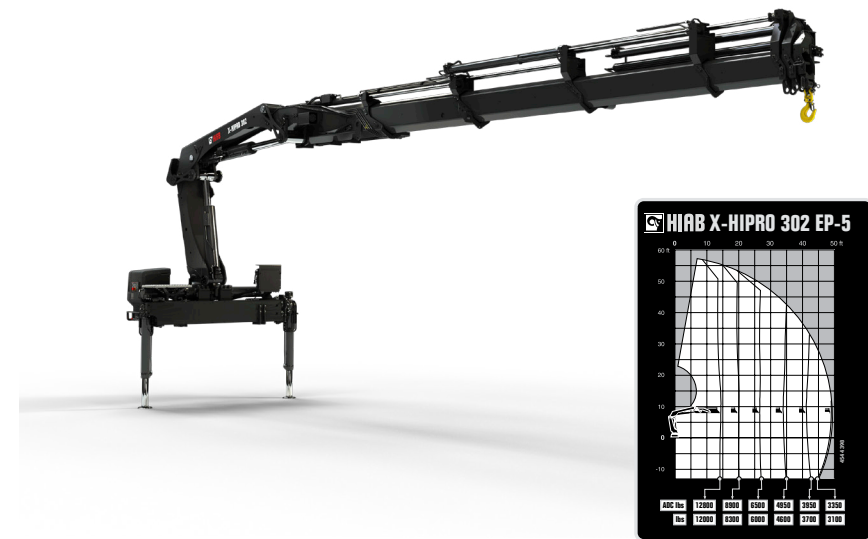

TECHNICAL DATA	X-DUO 128-3	X-HIDUO 138-3	X-HIPRO 142-3	X-DUO 148-2	X-HIDUO 158-3	X-HIPRO 162-3	X-DUO 178-2	X-HIDUO 188-4	X-HIPRO 192-3	X-DUO 218-2	X-HIDUO 228-3	X-HIPRO 232-3	X-HIDUO 258-4	X-HIPRO 262-6	X-HIDUO 298-2	X-HIPRO 302-5
Lifting capacity (ft-lbs)	75 250	79 660	79 660	87 770	92 900	92 900	106 000	107 810	115 700	125 030	131 690	137 330	146 520	143 770	179 220	175 530
Maximum outreach - Lifting capacity (lbs)	33' 10" - 2 200	33' 10" - 2 310	34' 1" - 2 430	33' 10" - 2 650	33' 10" - 2 870	34' 1" - 2 870	27' 7" - 4 100	34' 1" - 3 000	34' 9" - 3 400	27' 7" - 4 890	34' 5" - 3 920	34' 5" - 4 140	41' 4" - 3 480	52' 10" - 2 160	25' 11" - 7 500	49' 3" - 3 350
Weight, including stabilizers (lbs)	4 410	4 430	5 020	4 650	4 740	5 330	5 040	5 790	5 700	5 210	5 630	5 900	7 340	8 250	6 990	8 250
Control system	Duo	HiDuo	HiPro	Duo	HiDuo	HiPro	Duo	HiDuo	HiPro	Duo	HiDuo	HiPro	HiDuo	HiPro	HiDuo	HiPro